

 **Bonfiglioli**
Tecnoingranaggi

**Serie TQ-TQF-TQK
TR-MP-LC-LCK-SL-KR**

Spielarme Planetengetriebe

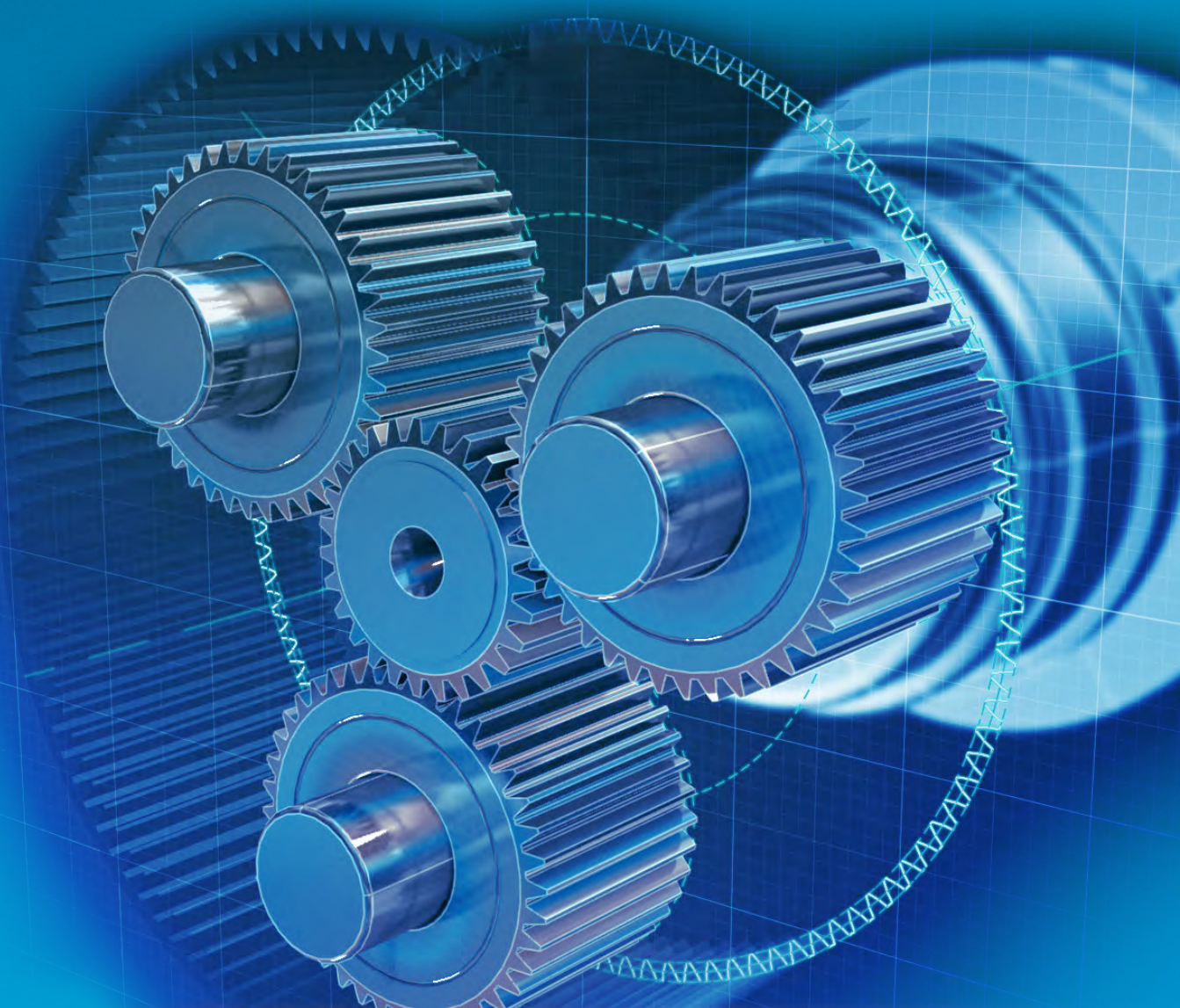

 **Bonfiglioli**
Forever Forward

Bonfiglioli solutions





3	Wir halten die Welt in Bewegung
4	Mechatronik – die Herausforderung, ihren Erfolg sicherzustellen
5	Unsere Kompetenz von Anfang bis Ende!
6	Ihr One-stop-shop für mechatronik Anwendungen
7	Leistungsfähigere, effizientere und kostengünstigere Konzepte
8	Optimierung des Servo-systems mittels Energiekostenmodell
9	Ein zuverlässiger Partner für ihr Geschäft
10	One-stop shop unser Service
11	Qualität und Technologie
12	Unsere Produkte auf einen Blick
14	Servogetriebe
15	Technische Informationen
16	1 Allgemeine Informationen
16	1.1 Symbole, Einheiten und Definitionen
18	1.2 Getriebeauswahl
22	1.3 Lagerlebensdauer
25	TQ-Reihe
26	2 Eigenschaften der TQ-Reihe
27	2.1 Bestellbezeichnung
28	2.2 Abmessungen und technische Daten
39	Neue TQF-Reihe
40	3 Eigenschaften der TQF-Reihe
41	3.1 Bestellbezeichnung
42	3.2 Abmessungen und technische Daten
53	TQK-Reihe
54	4 Eigenschaften der TQK-Reihe
55	4.1 Bestellbezeichnung
56	4.2 Abmessungen und technische Daten

67	TR-Reihe
68	5 Eigenschaften der TR-Reihe
70	5.1 Bestellbezeichnung
71	5.1.1 Versionen und Antriebsseite
71	5.1.2 Montagepositionen
71	5.2 Zulässige radial- und axialkräfte Für die Mb-version
72	5.3 Abmessungen und technische Daten
106	5.3.1 Maschinenwelle
107	MP-Reihe
108	6 Eigenschaften der MP-Reihe
110	6.1 Bestellbezeichnung
111	6.1.1 Versionen und Antriebsseite
111	6.1.2 Montagepositionen
111	6.2 Zulässige radial- und axialkräfte Für die Mb-version
112	6.3 Abmessungen und technische Daten
146	6.3.1 Maschinenwelle
147	LC-Reihe
148	7 Eigenschaften der LC-Reihe
149	7.1 Bestellbezeichnung
150	7.2 Abmessungen und technische Daten
169	LCK-Reihe
170	8 Eigenschaften der LCK-Reihe
171	8.1 Bestellbezeichnung
172	8.2 Abmessungen und technische Daten
191	SL-Reihe
192	9 Eigenschaften der SL-Reihe
193	9.1 Bestellbezeichnung
194	9.2 Abmessungen und technische Daten
207	KR-Reihe
208	10 Eigenschaften der KR-Reihe
209	10.1 Versionen
209	10.2 Montagepositionen
209	10.3 Wellendrehrichtung
210	10.4 Bestellbezeichnung
211	10.5 Technische Daten
212	10.6 Massenträgheitsmoment
212	10.6.1 KR 010...KR 040 mit standard Kugellagern (SB Option)
213	10.6.2 KR 020...KR 040 mit Kegelrollenlagern (HB Option)
214	10.7 Abmessungen
222	10.7.1 Getriebe ohne Motoradapter
223	10.7.2 Maschinenwelle

Änderungen

Das Revisionsverzeichnis des Katalogs wird auf Seite 224 wiedergegeben. Auf unserer Website www.bonfiglioli.com werden die Kataloge in ihrer letzten, überarbeiteten Version angeboten.

WIR HALTEN DIE WELT IN BEWEGUNG



Seit 1956 ist Bonfiglioli ein führender name in der Antriebstechnik mit dem Engagement als weltweit zuverlässiger Partner aufzutreten.

Unsere Best-in-Class-Lösungen beruhen auf fast 60 Jahren Fachkompetenz und profunden Branchenkenntnissen.



MECHATRONIK DIE HERAUSFORDERUNG, IHREN ERFOLG SICHERZUSTELLEN

Schneller, besser und günstiger – das sind die neuen Herausforderung für Maschinenentwickler!

Steigende Anforderungen an die Produktivität, komplexere Systeme und flexiblere Maschinen, die mit höchstem Wirkungsgrad betrieben werden, erfordern neue und intelligente technische Lösungen, um zukünftiges Wachstum zu gewährleisten.

Bonfiglioli hat eine präzise und detaillierte Strategie umgesetzt, um genau dieses Ziel zu erreichen.

Mit dem Engagement, Ihr weltweit führender Partner für intelligente Mechatroniklösungen und Servosysteme zu sein, hat der Geschäftsbereich Industrial Business zwei Abteilungen eingerichtet, um die jeweiligen Märkte mit Fachkompetenz und Sorgfalt zu betreuen:

- Power Transmission Solutions (PTS)
- Mechatronic Drives & Solutions (MDS)

Zielsetzung unserer neuen Abteilung Mechatronic Drives & Solutions (MDS): Rentabilitätssteigerung, indem sie im Bereich der industriellen Automation als verlässlicher Partner und Anbieter energieeffizienter Lösungen für den gesamten Lebenszyklus auftritt.

- Systemintegration
- Fachkompetenz
- Energieeinsparung

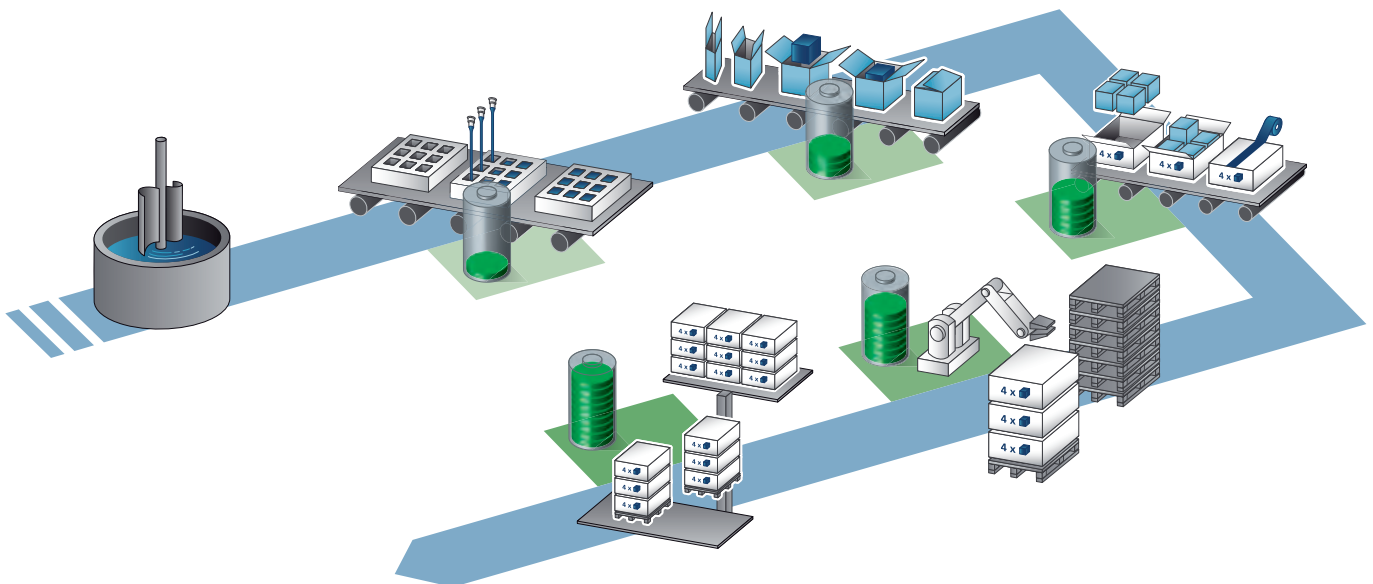

Leistung, Zuverlässigkeit, Kostengünstigkeit, Robustheit, Effizienz und Nachhaltigkeit sind unverzichtbar.

UNSERE KOMPETENZ VON ANFANG BIS ENDE!



MDS-Innovationen werden durch zwei Kompetenzzentren vorangebracht:

- Bonfiglioli Vectron GmbH in Deutschland, mit ausgeprägten Kompetenzen in Technik, Forschung und Entwicklung sowie Fertigung von elektronischen Komponenten, insbesondere Umrichtern und Servoantrieben
- BMR (Bonfiglioli Mechatronic Research) in Rovereto (Trento, Italien), mit umfassenden Forschungs- und Entwicklungsmöglichkeiten, um innovative neue Lösungen für Ihre speziellen Bedürfnisse bereitzustellen. BMR ist eine Produktionsanlage, in der neue Mechatroniklösungen realisiert werden.

Der Schlüssel zu unserem Erfolg ist der herausragende technische Support durch unsere DSC (Drive Service Center)-Spezialisten. Diese begleiten Sie während der gesamten Installationsphase – vom ersten Konzept bis zur abschließenden Inbetriebnahme.

Bonfiglioli

ist mit seinen weltweiten Niederlassungen und effizientem Kundendienst immer für Sie da.

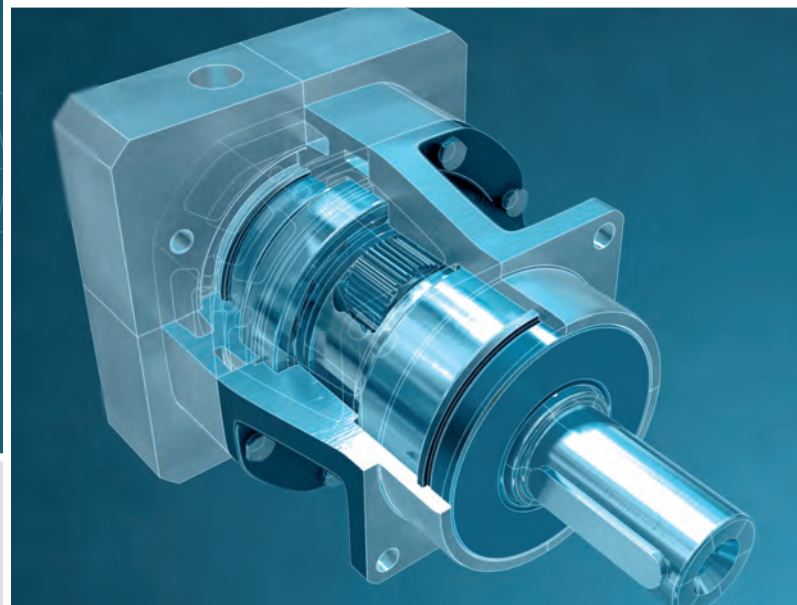
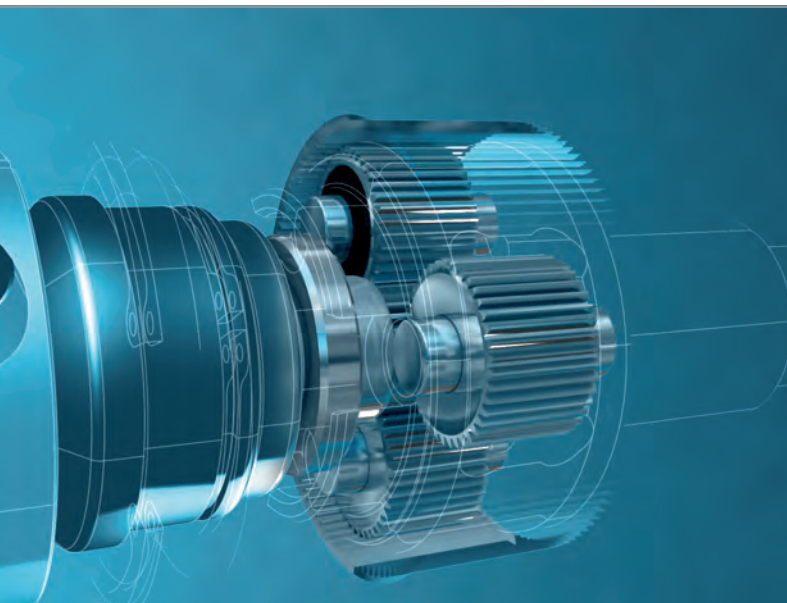

VOR-ORT-SERVICE

TECHNISCHE BETREUUNG

INBETRIEBNAHME

INSTANDHALTUNG

KUNDENDIENST

IHR ONE-STOP-SHOP FÜR MECHATRONIK ANWENDUNGEN

Als kompetenter Technologiepartner sorgen wir dafür, dass unsere Ingenieure **gemeinsam mit Ihnen maßgeschneiderte, zukunftsgerichtete und integrierte Lösungen realisieren, die Ihren individuellen Anforderungen entsprechen und energieeffiziente Mechatroniksysteme für Ihre Anwendung bereitstellen.**

Das Bonfiglioli Servo-Portfolio umfasst alle Komponenten, die für eine komplette Automatisierungslösung erforderlich sind:

- HMI – Bonfiglioli Mensch-Maschine-Schnittstelle
- Programmierbare Steuerung (ACU / ACT / AGL)
- Höchstdynamische geregelte Servomotoren (BMD-Reihe)
- Präzisions-Planetengetriebe (TQ, TQF, TQK, TR, MP, LC, LCK, SL)
- Präzisionskegelradgetriebe (KR)
- Konfektioniertes Zubehör (Kabel, Drosseln, Filter etc.)



Ihre Vorteile:

- Ihre Vorteile:
- Höchste Präzision & Dynamik
- Leistungstark & Kompakt
- Höchste radiale und axiale Tragfähigkeiten
- Höchste Kippmomente
- Laufruhig



Ihre Vorteile:

- Hohe Präzision und Dynamik
- Häufige Drehrichtungswechsel
- Höchste Leistungsdichte



Ihre Vorteile:

- Energieeinsparung
- Einfache Systemlösung
- Hoher Drehmomentbereich
- Präzise Vierquadrant-Drehzahl- und Geschwindigkeitssteuerung
- Höchste Leistungsdichte

Komplettes Automatisierungs-Paket von nur einem Anbieter!

LEISTUNGSFÄHIGERE, EFFIZIENTERE UND KOSTENGÜNSTIGERE KONZEPTE



Bonfiglioli ist Ihr Partner und unterstützt Sie bei der Dimensionierung, Optimierung und Auswahl des Antriebsstrangs.

Unser Schwerpunkt liegt nicht nur auf der Entwicklung und Fertigung von Produkten für Ihre Anforderungen, wir verfügen auch über Software-Tools, die Ihren Entwicklungsprozess vereinfachen.

Wir können Ihr Servo-Paket optimieren, um eine Überdimensionierung zu vermeiden, durch die sich sowohl die Anschaffungskosten als auch die laufenden Betriebskosten für ein Servosystem erhöhen würden.

The screenshot displays the SERVOSOFT software interface for a servo drive system. The main window shows a 3D model of a motor connected to a belt and pulley system. A sidebar on the left lists components like 'Sistema B asse Z', 'Belt and Pulley', 'T1: Gearbox', 'Drive & Motor', 'Sistema B asse Y', and another 'Belt and Pulley' and 'T1: Gearbox'. Below the 3D model is a graph showing a motion profile with velocity and acceleration curves over time. A table below the graph lists parameters for various components.

Nr.	Location	File Size (KB)	Duration (ms)	Displacement (mm)	Speed (mm/s)	Acc. (mm/s²)	Decel. (mm/s²)	Max. Torque (Nm)	Max. Power (W)	Max. Temp. (°C)	Max. Speed (mm/s)	Max. Acc. (mm/s²)	Max. Decel. (mm/s²)	Max. Torque (Nm)	Max. Power (W)	Max. Temp. (°C)	Max. Speed (mm/s)	Max. Acc. (mm/s²)	Max. Decel. (mm/s²)
1	Axis Z - Sistema Y Motor	4.26	0	0	-100	-750	0	0	0	0	0	0	0	0	0	0	0	0	0
2	Axis Z - Sistema Y Motor	4.26	0.2596	-41.8	-750	0	490	11.951	0	0	0	0	0	0	0	0	0	0	0
3	Axis Z - Sistema Y Motor	4.40	0	0	0	0	0	0	0	0	0	0	0	0	0	0	0	0	0
4	Apertura pinza	4.40	0.07	0	0	0	0	0	0	0	0	0	0	0	0	0	0	0	0
5	Axis Z - Sella 100 mm	5.18	0.2596	39.8	0	750	490	11.951	0	0	0	0	0	0	0	0	0	0	0
6	Axis Z - Sella 100 mm	5.4	0	0	0	750	0	0	0	0	0	0	0	0	0	0	0	0	0
7	Axis Z - Sella 100 mm	5.4	0.2225	61.8	750	0	-402	11.251	0	0	0	0	0	0	0	0	0	0	0
8	Axis Z - Sella 100 mm	5.53	0	0	0	0	0	0	0	0	0	0	0	0	0	0	0	0	0
9	Axis Z - Sella 100 mm	5.62	1.220	0	0	0	0	0	0	0	0	0	0	0	0	0	0	0	0

Req'd parameters:

- Sequence: 6,961 s
- Velocity: 1.636 %/s
- Acceleration: 4,002 %/s²
- Deceleration: 4,002 %/s²
- Load + Payload: 0,0392 kg-m³
- Thrust: -12 Nm
- Drive pulley output torque: 14,74 Nm
- Belt tensile force: 421 N
- Input torque: 15,51 Nm
- Rigidity at input: 3,567e+13 Nm/rad

The bottom right window shows 'Gears Load and Radial Loads' with a diagram of a gear and a table of load data:

Item	Req'd	Margin	Calculated
F2max	100 N	0.11	100 N
F2min	0 N	0.11	0 N
F2Hmax	500 N	443.0	43.0 N
F2Hmin	0 N	372.4	372.4 N
F2	0 N	0	0 N
F2r	0 N	0	0 N
F2a	22 N	0	22 N
F2b	16 N	13.85	12.78 N
F2c	0 N	11.781	0 N
Lda	20000 t		

Individuell optimierte Lösungen von einem einzigen Anbieter.

OPTIMIERUNG DES SERVO-SYSTEMS MITTELS ENERGIEKOSTENMODELL

Die meisten modernen Servosysteme sind dafür ausgelegt, elektrisch gekoppelt zu werden, um Energie zu sparen, unnötige oder überdimensionierte Komponenten weitgehend zu minimieren und sowohl die anfänglichen Hardwarekosten als auch die Betriebskosten durch eine verbesserte Energieeffizienz zu senken.

Mit den stetig steigenden Energiepreisen ist die Energieeffizienz zu einem vorrangigen Entwicklungsziel geworden. Energiekosten können bis zu 95% der Lebenskosten eines Servosystems ausmachen.

Bonfiglioli optimiert die Effizienz des gesamten Antriebsstrangs durch eine detaillierte Analyse, mit der das Energieeinsparpotenzial ermittelt und bewertet wird.

Energy: \$ 129,12/year	Units	Sistema B asse Z	Sistema B asse Y
Output peak power	W	444	304,6
Regen cont power	W	0	18,42
Regen peak power	W	0	256,8
Energy	kWh/year	369	41,9
Energy cost	\$/year	36,90	4,19
T1			
		Gearbox	
Output cont power	W	62,2	21,08
Output peak power	W	428	293,5
Regen cont power	W	0	19,03
Regen peak power	W	0	264,9
Energy	kWh/year	20,53	17,96
Energy cost	\$/year	2,05	1,81
Mechanism			
		Belt and Pulley	
Output cont power	W	62,2	21,08
Output peak power	W	428	293,5
Regen cont power	W	0	19,03
Regen peak power	W	0	264,9
Energy	kWh/year	543	17,96
Energy cost	\$/year	54,33	1,81
Total			
Energy	kWh/year	992	236,2
Energy cost	\$/year	99,20	23,62

Wie ist die Energieverteilung entlang der kinematischen Kette?

Wie groß ist das Optimierungspotenzial der Anwendung hinsichtlich Energieeinsparung?



EIN ZUVERLÄSSIGER PARTNER FÜR IHR GESCHÄFT



Bonfiglioli verfügt über jahrzehntelange Erfahrungen mit Kunden aus den verschiedensten Industriesektoren.

Unsere Fachkompetenz besteht darin, dass wir Ihre Anwendungen kennen: Produkte und Anforderungen müssen aufeinander abgestimmt sein und eine Lösung darstellen, die Ihren Bedürfnissen gerecht wird. Mit unseren individuellen Lösungen erhalten Sie stets ein vollständiges Paket.

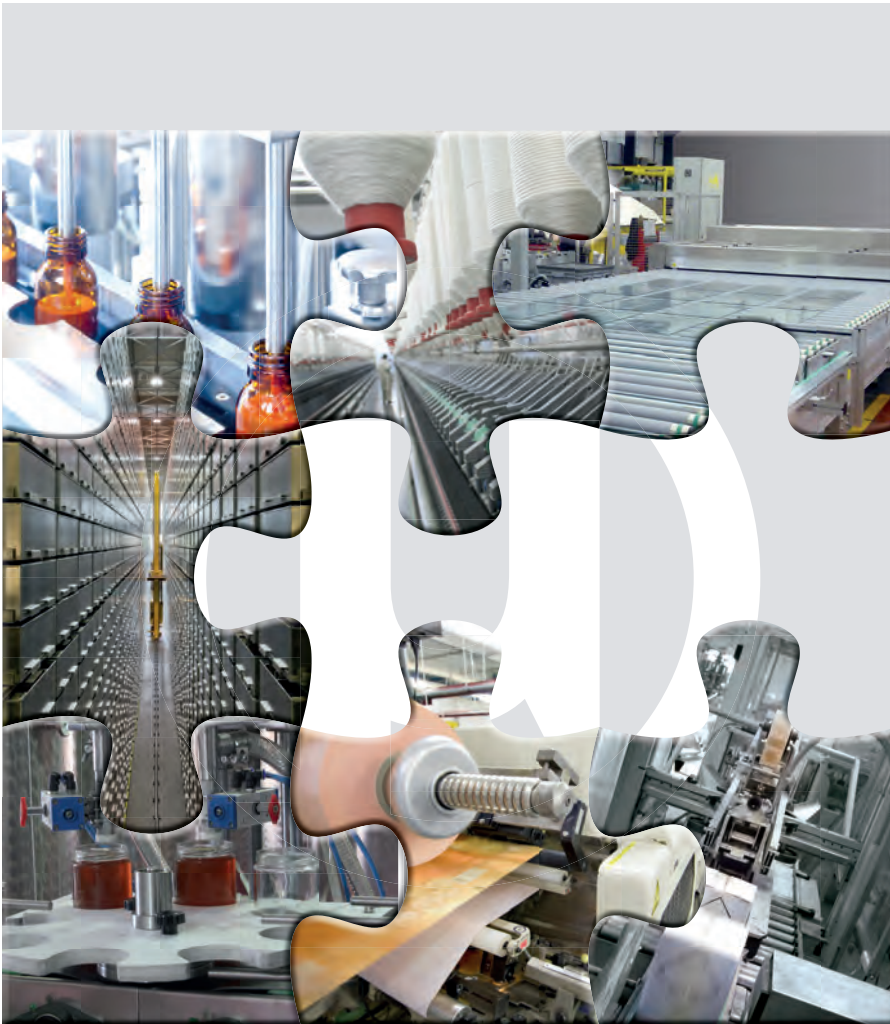

Einige unserer Anwendungsbereiche:

- Gewerbliche HLK-Systeme
- Werkzeugmaschinen
- Verpackung und Etikettierung
- Lebensmittel-, Getränke- und Tabakindustrie
- Textilien
- Glasbearbeitung
- Robotik
- Materialwirtschaft
- Gummi und Kunststoffe
- Papier und Kartonagen
- Förderanlagen
- Elektronik und Elektronikbauteile
- Krane und Hebebühnen
- Holzbearbeitung
- Energieerzeugung
- Erneuerbare Energie
- Materialumwandlung
- Bergbau
- Aufzüge

Und viele weitere

ONE-STOP SHOP UNSER SERVICE

Alle Bonfiglioli-Systeme sind weltweit mit einer zeitnahen und zuverlässigen technischen Unterstützung verbunden.

Spezialisten mit profunden Fachkenntnissen des jeweiligen Markts stehen mit Serviceleistungen wie Beratung, Installation, Kundendienst und Benutzerdokumentation zur Verfügung.

Wir verfügen über ein umfassendes Angebot an Dienstleistungen, die auf die individuellen Wünsche und Bedürfnisse unserer Kunden zugeschnitten sind.

- Optimale Lieferfristen für Ihre Produkte und schnelle Lieferungen bei ungeplanten und dringenden Anfragen
- Ermittlung individueller Lösungen durch umgehende professionelle technische Unterstützung
- Kurze Reaktionszeit und rasche Lieferung von Ersatzteilen in zeitkritischen Situationen

VOR DER
INBETRIEBNAHME

NACH DER
INBETRIEBNAHME



Mechanik- und Mechatronik-Studien



Produktanpassung



Prototypisierung, Test- und Analyseberichte



Unterstützung bei der Inbetriebnahme



Instandhaltung

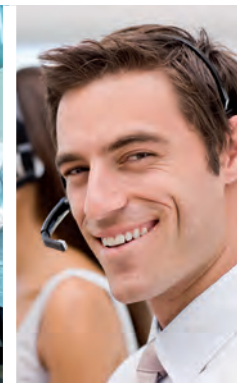

Kundendienst

SCHULUNG

QUALITÄT UND TECHNOLOGIE





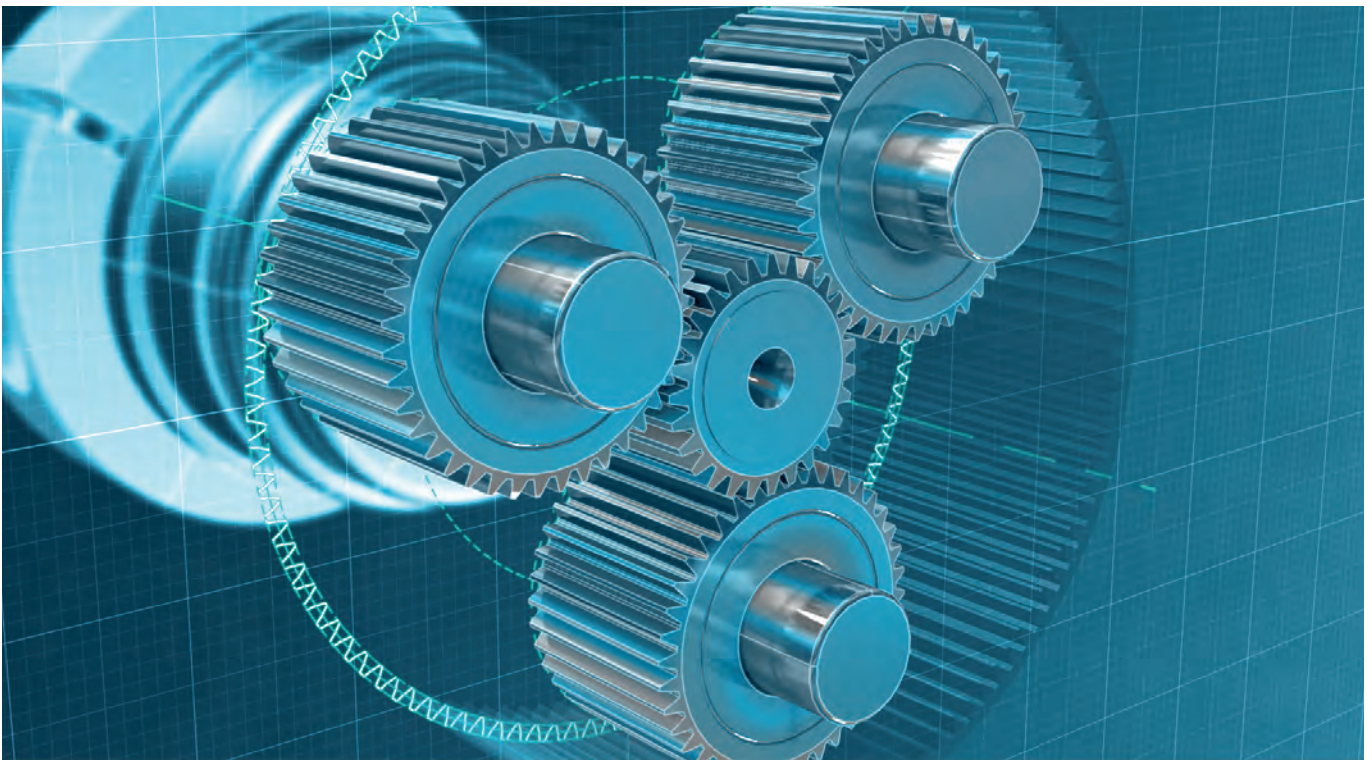





Produktzuverlässigkeit wird durch einen auf maximale Qualität ausgelegten Produktionsprozess erreicht.
Moderne Maschinen waren stets zentraler Bestandteil von Bonfiglioli's Produktionssystem.

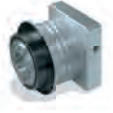

Bonfiglioli räumt der Qualität und Effizienz seines Maschinenparks schon immer absoluten Vorrang ein und investiert entsprechend.

UNSERE PRODUKTE AUF EINEN BLICK

HOHE LEISTUNGSDICHTE

	PRODUKT	KOAXIAL	RECHTWINKLIG	PRODUKTMERKMALE	KONFIGURATIONEN
HOCHLEISTUNG	TQ 	Ja		<ul style="list-style-type: none"> • Höchste Präzision und Dynamik • Hohe Eingangsdrehzahl • Höchste axiale und radiale Belastbarkeit • Laufruhig • Modulares Design für Ihre Anforderungen 	• Vollwelle
	NEUE TQF 	Ja		<ul style="list-style-type: none"> • Höchste Präzision & Dynamik • Leistungsstark & Kompakt • Höchste radiale und axiale Tragfähigkeiten • Höchste Kippmomente • Laufruhig 	• Flanschwelle
	TQK 		Ja	<ul style="list-style-type: none"> • Höchste Präzision und Dynamik • Hohe Eingangsdrehzahl • Höchste axiale und radiale Belastbarkeit • Laufruhig • Modulares Design für Ihre Anforderungen 	• Vollwelle
PRÄZISION	TR 	Ja	Ja	<ul style="list-style-type: none"> • Hohe Leistungsfähigkeit • Hohe Präzision • Modulares Design für Ihre Anforderungen 	<ul style="list-style-type: none"> • Vollwelle • Hohlwelle • Antriebsseitige Vollwelle
	MP 	Ja	Ja	<ul style="list-style-type: none"> • Hohe Leistungsfähigkeit • Mittlere Präzision • Modulares Design für Ihre Anforderungen 	<ul style="list-style-type: none"> • Vollwelle • Hohlwelle • Antriebsseitige Vollwelle
FLEXIBILITÄT	LC 	Ja		<ul style="list-style-type: none"> • Flexibel • Mittlere Präzision • Neue Option mit mehr Drehmoment verfügbar 	<ul style="list-style-type: none"> • Vollwelle • Antriebsseitige Vollwelle
	LCK 		Ja	<ul style="list-style-type: none"> • Flexibel • Mittlere Präzision • Neue Option mit mehr Drehmoment verfügbar 	<ul style="list-style-type: none"> • Vollwelle • Antriebsseitige Vollwelle
	SL 	Ja		<ul style="list-style-type: none"> • Dynamische Riemenanwendung • Kompaktheit • Mittlere Präzision • Neue Option mit mehr Drehmoment verfügbar 	• Vollwelle
	KR 			Ja	Präzision, Dynamik und Kompaktheit zu einem unschlagbaren Preis



MAX. NENNDREHMOMENT MAX. BESCHL.- MOMENT	ÜBERSETZUNG I	DREHM.-DICHT	TORSIONSSTEIFIGKEIT	VERDREHSPIEL	KONFIGURATIONEN
[Nm]	[-]			[arcmin]	
800 1200	3-100	●●●●●	●●●●	STANDARD ≤ 4-6 REDUZIERT ≤ 2-4	●●●●●
800 1200	4-100	●●●●●	●●●●●	STANDARD ≤ 5-7 REDUZIERT ≤ 3-5	●●●●●
800 1200	6-200	●●●●●	●●●●	STANDARD ≤ 5-7 REDUZIERT ≤ 4-6	●●●●●
1000 1200	3-1000	●●●	●●●	STANDARD ≤ 5-7 REDUZIERT ≤ 3-5	●●●
1000 1200	3-1000	●●●	●●●	STANDARD ≤ 15-17 REDUZIERT ≤ 10-12	●●●
450 700	3-100	●●●	●●●	STANDARD ≤ 12-15 REDUZIERT ≤ 6-8	●●●
450 700	6-100	●●●	●●●	STANDARD ≤ 6-8	●●●
155 300	3-100	●●●	●●●	STANDARD ≤ 12 REDUZIERT ≤ 6	●●●
120 170	1-5	●	●	STANDARD ≤ 8	●

SERVOGETRIEBE

Positionierungssanwendungen machen den Einsatz von spielarmen Planetengetrieben erforderlich, um Drehzahlen und Drehmomente anzupassen und gleichzeitig die anwendungsspezifische Präzision zu gewährleisten.

Bonfiglioli hat sich für den Einsatz von Präzisions-Planetengetrieben zusammen mit der Permanentregnte-Synchronmotoren-Reihe BMD entschieden.

In Verbindung mit einer leistungsfähigen Antriebselektronik sind diese Getriebe für Servoanwendungen ausgelegt, die höchste Leistung hinsichtlich Dynamik, Präzision, Robustheit, Haltbarkeit und Lebensdauer erfordern .

Eine wichtige Voraussetzung für Automatisierungsanwendungen ist eine hohe Drehmomentkapazitätalsein kompaktes und leichtes Paket. Diese hohe Drehmomentdichte (ein hohes Drehmoment/Volumen- oder Drehmoment/ Gewicht-Verhältnis) ist wichtig, um bei Automatisierungsanwendungen mit hoher dynamischer Belastung zusätzliche Systemträgheit zu vermeiden.

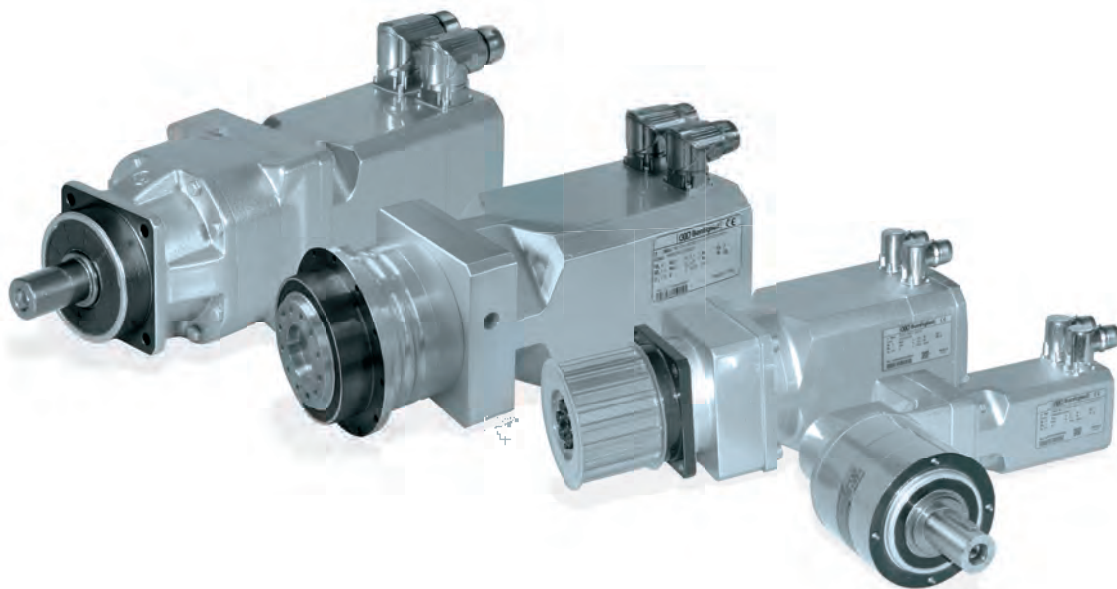



1 ALLGEMEINE INFORMATIONEN

1.1 SYMBOLE, EINHEITEN UND DEFINITIONEN

Anwendungsspezifische Werte

bezeichnung	einheit	definition
A_2	[N]	Axialkraft an der Abtriebswelle
$A_2 \text{ EQU}$	[N]	Äquivalente Axialkraft an der Abtriebswelle
$A_2 \text{ MAX}$	[N]	Maximale Axialkraft an der Abtriebswelle
R_2	[N]	Radialkraft an der Abtriebswelle
$R_2 \text{ EQU}$	[N]	Äquivalente Radialkraft an der Abtriebswelle
$R_2 \text{ MAX}$	[N]	Maximale Radialkraft an der Abtriebswelle
ED	[s]	Belastungsdauer (ohne Bremse)
ED%	[%]	Einschaltdauer
$L_{10h \text{ TARGET}}$	[h]	Nominelle Ziellebensdauer der Abtriebswellenlager
$M_1 \text{ PEAK}$	[Nm]	Maximales Eingangsdrehmoment (begrenzt durch Motorsteuerung)
$M_2(1) \dots M_2(n)$	[Nm]	Ausgangsdrehmoment im Zeitfenster $t_1 \dots t_n$
$M_2 \text{ EQU}$	[Nm]	Äquivalentes Abtriebsdrehmoment
$M_2 \text{ MAX}$	[Nm]	Not-Aus-Moment
$M_{T2 \text{ EQU}}$	[Nm]	Äquivalentes Kippmoment an der Abtriebswelle
$M_{T2 \text{ MAX}}$	[Nm]	Maximales Kippmoment an der Abtriebswelle
n_1	[min ⁻¹]	Nominelle Eingangsdrehzahl
n_2	[min ⁻¹]	Ausgangsdrehzahl
$n_2(1) \dots n_2(n)$	[min ⁻¹]	Ausgangsdrehzahl im Zeitfenster $t_1 \dots t_n$
$n_2 \text{ EQU}$	[min ⁻¹]	Äquivalente Ausgangsdrehzahl
$n_2 \text{ MAX}$	[min ⁻¹]	Maximale Ausgangsdrehzahl
T	[C°]	Umgebungstemperatur
$t_1 \dots t_n$	[s]	Betriebsdauer
t_Σ	[s]	Einschaltdauer inkl. Pause
Z	[1/h]	Zyklen pro Stunde



Getriebespezifische Werte

bezeichnung	einheit	definition
$A_{2/3 \max}$	[N]	Zulässige Axialkraft an der Abtriebswelle
$A_{2/3' \max}$	[N]	Gleichzeitig mit der Radialkraft einwirkende Axialkraft
$R_{1 \max}$	[N]	Zulässige Radialkraft am Mittelpunkt der Eintriebswelle
$R_{2/3 \max}$	[N]	Zulässige Radialkraft am Mittelpunkt der Abtriebswelle
C_B	[Nm]	Konstante zur Berechnung der Lagerlebensdauer
C_t	$\left[\frac{\text{Nm}}{\text{arcmin}} \right]$	Torsionssteifigkeit
f	—	Verhältnis zwischen Axial- und Radialkraft
f_n	—	Drehzahlfaktor
f_z	—	Zyklusfaktor
f_T	—	Temperaturfaktor
i	—	Getriebeübersetzung
J_G	[kgcm ²]	Massenträgheitsmoment des Getriebes
K_n	—	Drehzahlkonstante
L_{10h}	[h]	Allgemeine Lagerlebensdauer
L_z	[mm]	Faktor zur Berechnung der Lagerlebensdauer
$M_{a 2}$	[Nm]	Maximal zulässiges Abtriebsbeschleunigungsmoment
$M_n 2$	[Nm]	Nominales Abtriebsdrehmoment
$M_p 2$	[Nm]	Not-Aus-Moment 1000 mal während der Nutzungsdauer des Getriebes zulässig
$M_{T2 \max}$	[Nm]	Maximal zulässiges Kippmoment an der Abtriebswelle
$n_{1 \max}$	[min ⁻¹]	Spitzen-Eingangsdrehzahl. Drehzahl, mit der die Einheit gelegentlich, unter sich nicht wiederholenden Bedingungen betrieben werden kann. Im S5-Betrieb darf dies nicht länger als 30 Sekunden dauern.
p	—	Lagerlebensdauerexponent
η	[%]	Getriebewirkungsgrad
φ_R	[arcmin]	Reduziertes Flankenspiel, wird unter statischen Bedingungen und bei einem Drehmoment von 2% des Getriebeendrehmoments ermittelt.
φ_S	[arcmin]	Standard Flankenspiel, wird unter statischen Bedingungen und bei einem Drehmoment von 2% des Getriebeendrehmoments ermittelt.



1.2 GETRIEBEAUSWAHL

(a)	Übersetzung	i	—	$i = \frac{n_1}{n_2}$
(b)	Äquivalentes Abtriebsdrehmoment	$M_{2\text{ EQU}}$	[Nm]	$M_{2\text{ EQU}} = \sqrt[3]{\frac{ n_{2(1)} \cdot t_1 \cdot M_{2(1)} ^3 + \dots + n_{2(n)} \cdot t_n \cdot M_{2(n)} ^3}{ n_{2(1)} \cdot t_1 + \dots + n_{2(n)} \cdot t_n}}$
(c)	Äquivalente Ausgangsdrehzahl	$n_{2\text{ EQU}}$	[min ⁻¹]	$n_{2\text{ EQU}} = \frac{ n_{2(1)} \cdot t_1 + n_{2(2)} \cdot t_2 + \dots + n_{2(n)} \cdot t_n}{t_\Sigma}$
(d)	Drehzahlfaktor	f_n	—	<p>Wenn $\frac{K_n}{n_{2\text{ EQU}} \cdot i} \geq 1 \Rightarrow f_n = 1$</p> <p>Wenn $\frac{K_n}{n_{2\text{ EQU}} \cdot i} < 1 \Rightarrow f_n = \text{Dem Diagramm entnehmen}$</p>
(e)	Temperaturfaktor	f_T	—	
(f)	Einschaltdauer	ED%	[%]	$ED\% = \frac{ED}{t_\Sigma} \cdot 100$
	Belastungsdauer	ED	[s]	$ED = t_1 + t_2 + \dots + t_n$
(g)	Zyklen pro Stunde	Z	[1/h]	$Z = \frac{3600}{t_\Sigma}$
(h)	Zyklusfaktor*	f_z	—	<p>*Für Z>6000 Bonfiglioli kontaktieren!</p>
(i)	Maximales Eingangsmoment	$M_{1\text{ PEAK}}$	[Nm]	<p>a) Maximal mögliches Anwendungsdrehmoment</p> <p>b) Per Umrichter begrenztes Motordrehmoment</p> <p>c) Maximales Motordrehmoment</p>

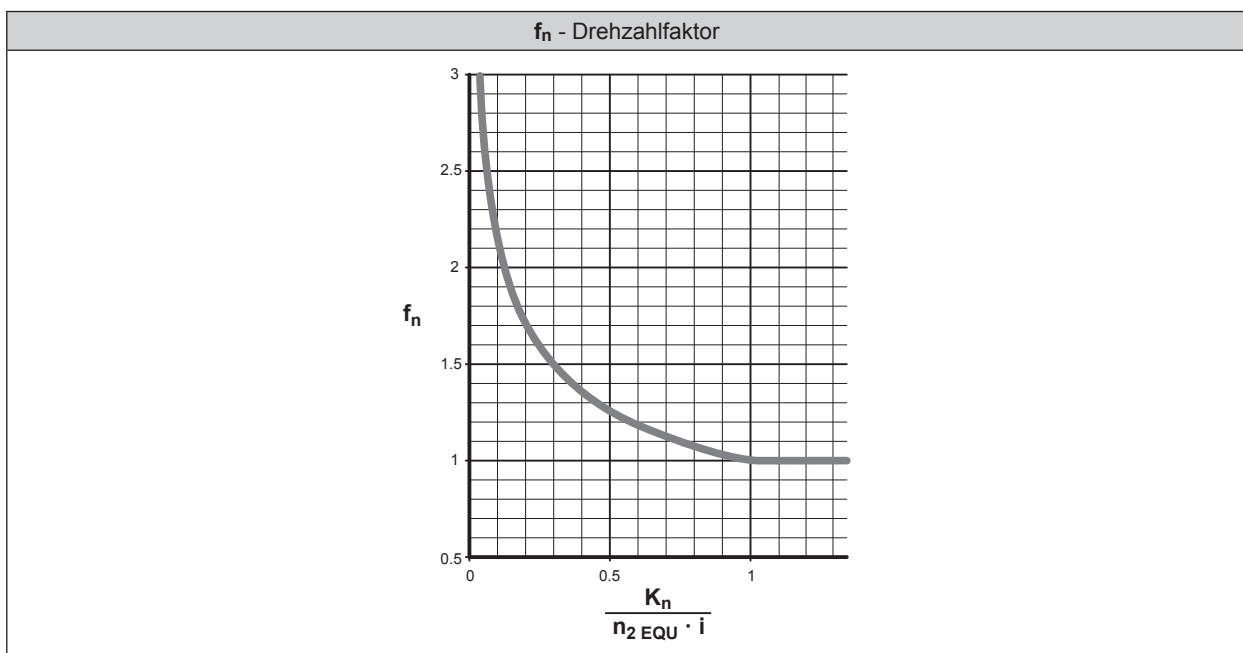



Belastungsdiagramm

— M_2 : Abtriebsdrehmoment

Drehzahldiagramm

— n_2 : Ausgangsdrehzahl

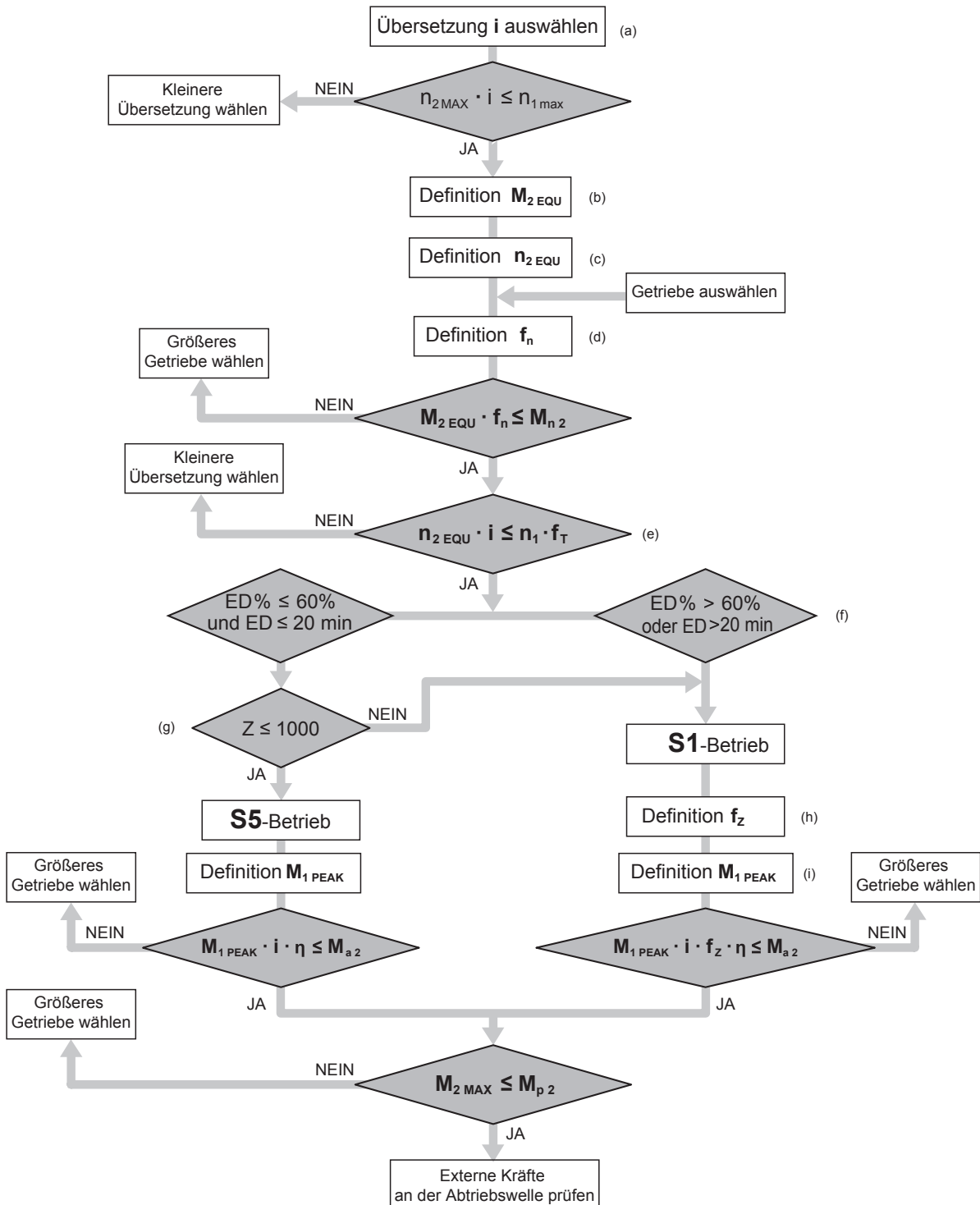
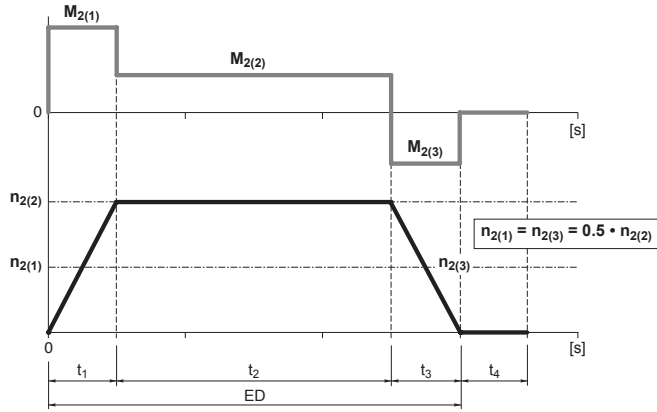

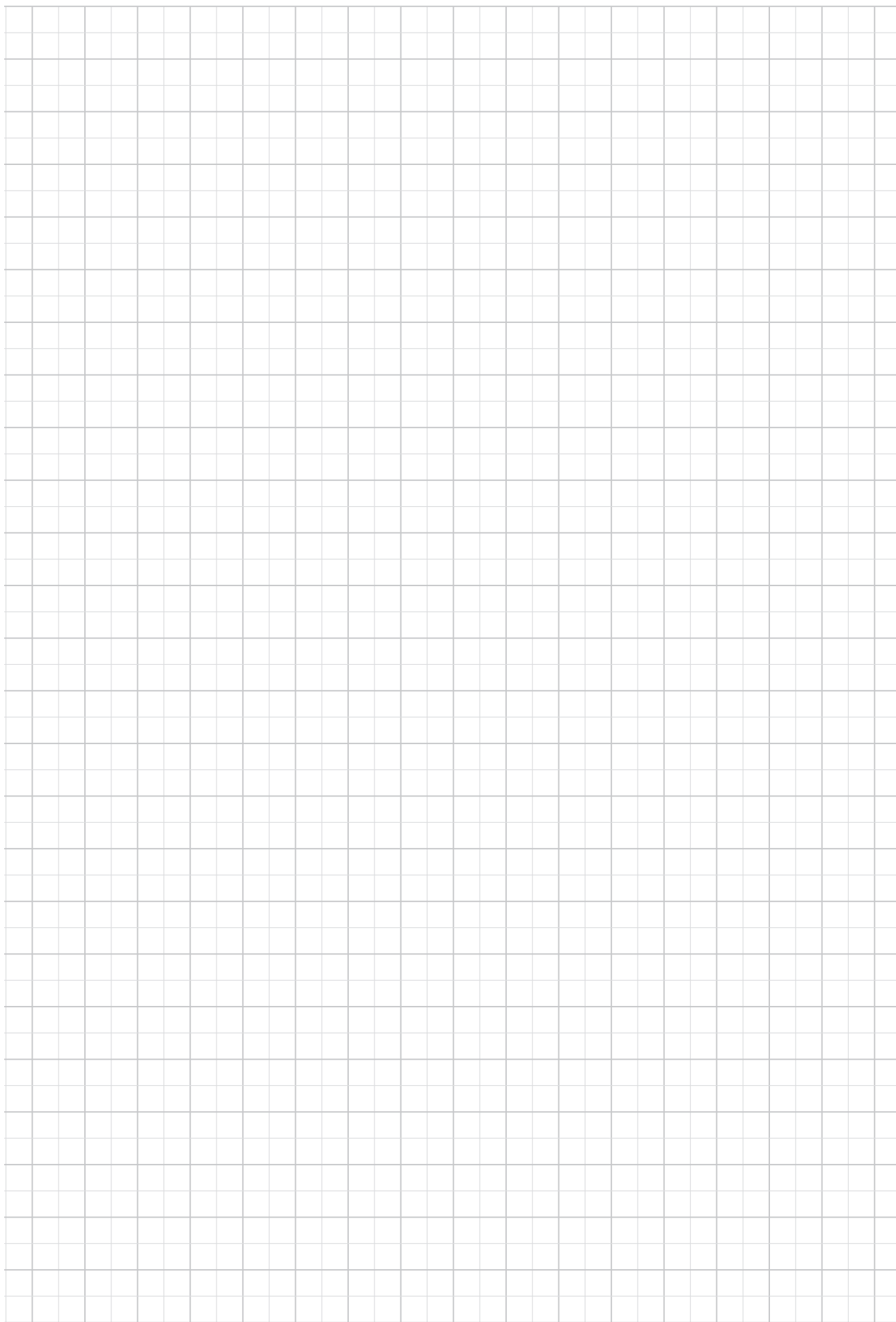



1.3 LAGERLEBENSDAUER

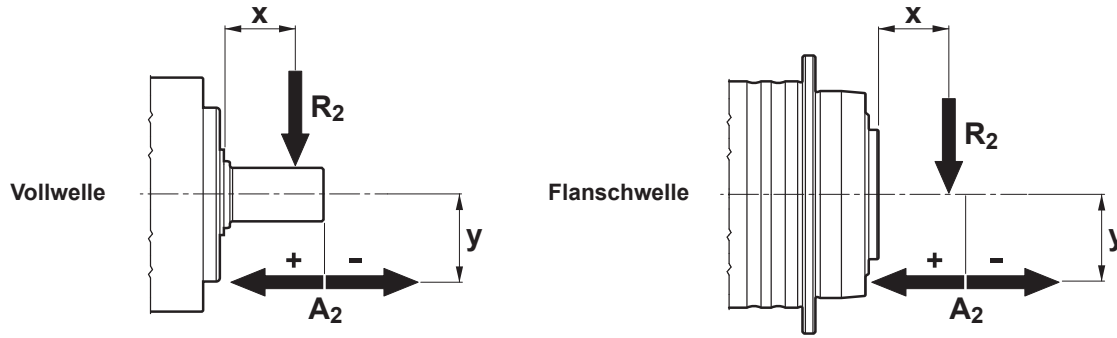

(a)	Maximale Radialkraft an der Abtriebswelle Maximale Axialkraft an der Abtriebswelle	$R_{2\text{ MAX}}$ $A_{2\text{ MAX}}$	[N] [N]	Bitte die spezifischen Bedingungen beachten (z. B. Riementriebe unter Beschleunigungsmoment)
(b)	Maximales Kippmoment an der Abtriebswelle	$M_{T2\text{ MAX}}$	[Nm]	$M_{T2\text{ MAX}} = \frac{R_{2\text{ MAX}} \cdot (x + L_z) \pm A_{2\text{ MAX}} \cdot y}{1000}$
(c)	Äquivalente Kräfte an der Abtriebswelle	$R_{2\text{ EQU}}$	[N]	$R_{2\text{ EQU}} = \sqrt[3]{\frac{ n_{2(1)} \cdot t_1 \cdot R_{2(1)} ^3 + \dots + n_{2(n)} \cdot t_n \cdot R_{2(n)} ^3}{ n_{2(1)} \cdot t_1 + \dots + n_{2(n)} \cdot t_n}}$
		$A_{2\text{ EQU}}$	[N]	$A_{2\text{ EQU}} = \sqrt[3]{\frac{ n_{2(1)} \cdot t_1 \cdot A_{2(1)} ^3 + \dots + n_{2(n)} \cdot t_n \cdot A_{2(n)} ^3}{ n_{2(1)} \cdot t_1 + \dots + n_{2(n)} \cdot t_n}}$
(d)	Äquivalentes Kippmoment an der Abtriebswelle	$M_{T2\text{ EQU}}$	[Nm]	$M_{T2\text{ EQU}} = \frac{R_{2\text{ EQU}} \cdot (x + L_z) + A_{2\text{ EQU}} \cdot y}{1000}$
(e)	Äquivalente Ausgangsdrehzahl	$n_{2\text{ EQU}}$	[min ⁻¹]	$n_{2\text{ EQU}} = \frac{ n_{2(1)} \cdot t_1 + n_{2(2)} \cdot t_2 + \dots + n_{2(n)} \cdot t_n}{t_1 + t_2 + \dots + t_n}$
(f)	Allgemeine Lagerlebensdauer	L_{10h}	[h]	$L_{10h} = \frac{16666}{n_{2\text{ EQU}}} \cdot \left(\frac{C_B}{M_{T2\text{ EQU}}} \right)^p$

		TQ / TQK 060		TQ / TQK 070		TQ / TQK 090		TQ / TQK 130	TQ / TQK 160
		SB	SB	HB	SB	HB	SB	SB	
L_z	[mm]	56	67	64	95	89	96	114	
$M_{T2\text{ max}}$	[Nm]	129.5	221	343	592	772	1233	2331	
C_B	[Nm]	632	1065	1510	2898	3325	6395	9795	
p	—	3	3	3.33	3	3.33	3.33	3.33	

		TQF 060	TQF 070	TQF 090	TQF 130	TQF 160
L_z	[mm]	48	72	78	100	128
$M_{T2\text{ max}}$	[Nm]	115	318	430	1200	3700
C_B	[Nm]	490	1335	1815	5055	16200
p	-	3.33	3.33	3.33	3.33	3.33

		TR 053	TR 060	TR 080	TR 105	TR 130	TR 160	TR 190
		SB	SB	SB	SB	SB	SB	SB
L_z	[mm]	22	23	42	53	74	94	100
$M_{T2\text{ max}}$	[Nm]	16	23	155	278	515	739	1683
C_B	[Nm]	91	143	994	2048	3893	5824	8680
p	—	3	3	3.33	3.33	3.33	3.33	3.33

		MP 053	MP 060	MP 080		MP 105		MP 130	MP 160	MP 190
		SB	SB	SB	HB	SB	HB	SB	SB	SB
L_z	[mm]	22	23	44	42	46	53	74	94	100
$M_{T2\text{ max}}$	[Nm]	16	23	83	155	99	278	515	739	1683
C_B	[Nm]	91	143	407	994	637	2048	3893	5824	8680
p	—	3	3	3	3.33	3	3.33	3.33	3.33	3.33

		LC / LCK 050	LC / LCK / SL 070	LC / LCK / SL 090	LC / LCK / SL 120	LC / LCK 155
L_z	[mm]	22	28	30	39	46
$M_{T2\text{ max}}$	[Nm]	15	54	105	238	522
C_B	[Nm]	106	280	298	813	1588
p	—	3	3	3	3	3

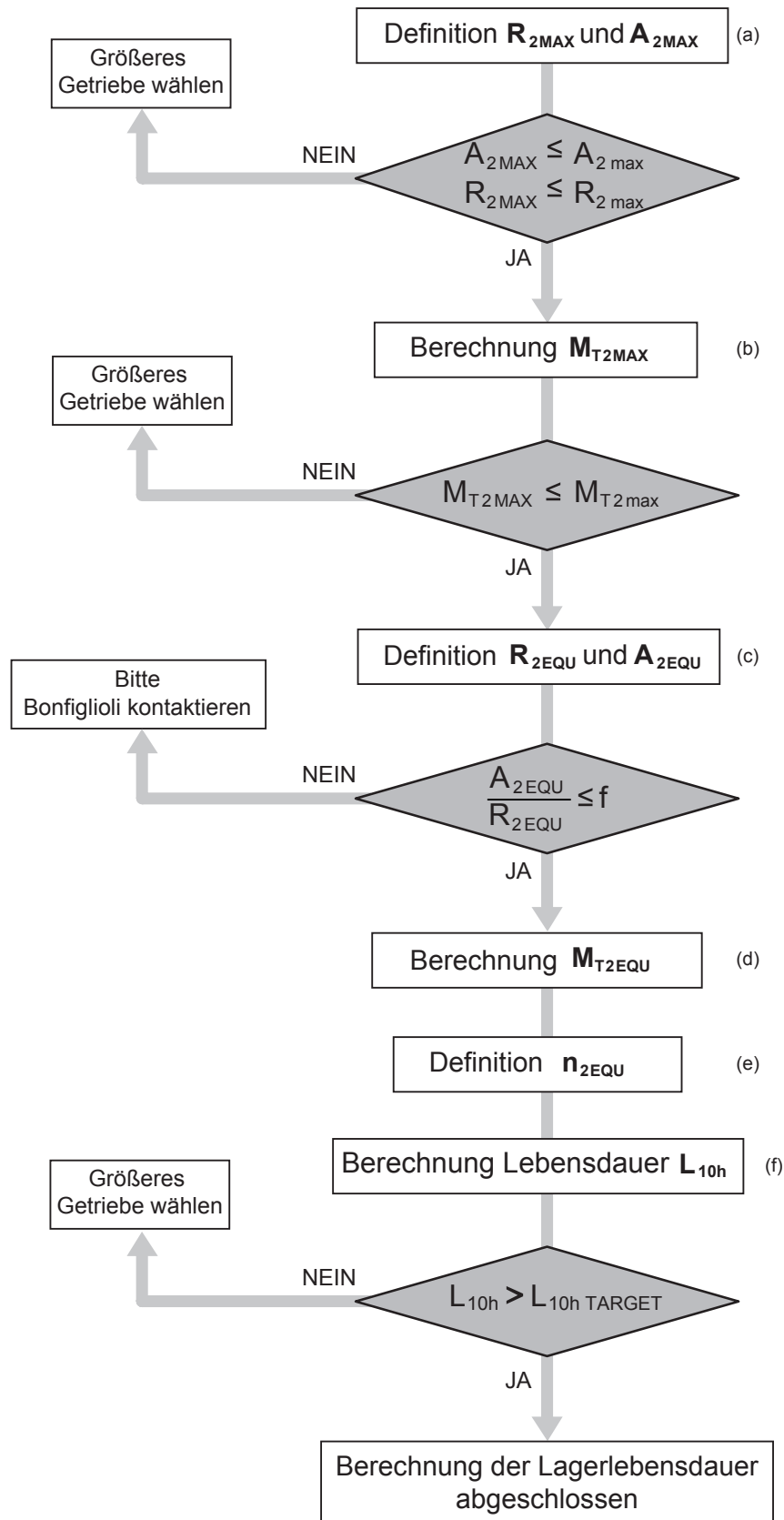

f	TQ / TQK	TQF	TR	MP	LC / LCK	SL	KR
0.26	060 SB ... 090 SB		053 SB ... 060 SB	053 SB ... 105 SB	050 SB ... 155 SB	070 SB ... 120 SB	010 SB ... 040 SB
0.37	130 SB ; 160 SB 070 HB ; 090 HB	060 ... 160	080 SB ... 190 SB	130 SB ... 190 SB 080 HB ; 105 HB			020 HB ... 040 HB



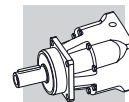

TQ

KOAXIALE PRÄZISIONSPLANETENGETRIEBE

TQ

Die TQ Getriebe stehen an der Spitze des Produktportfolios. Ob Drehmoment, Steifigkeit oder Präzision – diese attraktive Produktreihe punktet in jeder Kategorie.

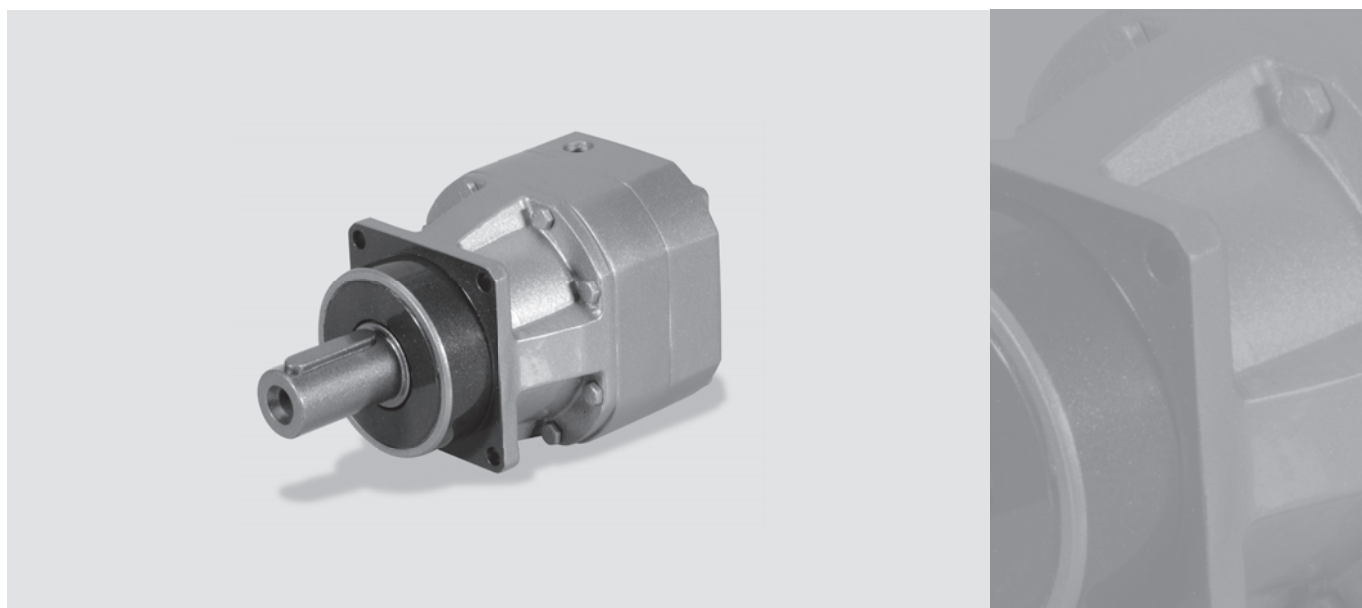

Produktmerkmale:

- Höchste Drehmomentdichte
- Höchstes Beschleunigungs- und Nenndrehmoment
- Höchste radiale und axiale Belastbarkeit
- Entwickelt für Zyklus- und Dauerbetrieb
- Höchste Verdrehsteifigkeit
- Niedriges Verdrehflankenspiel – unter 2 arcmin
- Laufruhig
- Einsetzbar in beliebiger Montageposition

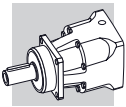

2 EIGENSCHAFTEN DER TQ-REIHE

TQ

Die spielarmen Planetengetriebe der TQ-Reihe vereinen herausragendes Leistungsverhalten mit charakteristischem italienischen Design, das sie von ähnlichen Produkten in der Branche unterscheidet.

Entwicklung und Konstruktion folgten dem Ziel eine Produktreihe mit uneingeschränkter und konstanter Qualität bereitzustellen, die den Wettbewerbsvorteil beim Einsatz in Ihren Maschinen und Systemen darstellt.

- Die TQ-Reihe hat zwei Präzisionsklassen, mit diesem Verdrehflankenspiel:
 - 1-stufige Getriebe: standard $\varphi_S \leq 3'$ reduziert $\varphi_R \leq 2'$ ($\varphi_S \leq 4'$; $\varphi_R \leq 2'$ for TQ 060 and TQ 070)
 - 2-stufige Getriebe: standard $\varphi_S \leq 5'$ reduziert $\varphi_R \leq 3'$ ($\varphi_S \leq 6'$; $\varphi_R \leq 4'$ for TQ 060 and TQ 070)
- Eine hohe IP-Schutzklasse (IP65) sorgt dafür, dass innenliegende Teile vor Staub- und Flüssigkeitseintritt geschützt sind.
- Serienmäßige Fluorelastomer-Wellendichtungen an der Eingangswelle
- Schalldruckpegel $60 \leq L_p \leq 70$ dB(A). Gemessen in 1 m Abstand ohne Last und bei einer Eingangsrehzahl von $n_1 = 3000 \text{ min}^{-1}$; $i = 10$.
- Große Auswahl an Motoradaptern sorgt für den Anschluss an die marktgängigsten Servomotoren. Große Auswahl an Motoradaptern sorgt für den Anschluss an die marktgängigsten Servomotoren. Große Auswahl an Motoradaptern sorgt für den Anschluss an die marktgängigsten Servomotoren.
- Schmierung optimiert für die gewünschte Betriebsart. Ohne Verunreinigung muss das Schmiermittel nicht regelmäßig gewechselt werden.

Betrieb	TQ 060 ... TQ 160	andere Dichtungen
S1 (kontinuierlich)	Synthetiköl Viskositätsklasse ISO VG 220	Fluorelastomer
S5 (unterbrochen)	NLGI Fettkonsistenz 00	NBR

- Umgebungstemperatur min. -20°C , max. $+30^\circ\text{C}$; bei Temperaturen höher als 30°C ist der Temperaturfaktor f_T zu berücksichtigen.
- Die Gehäusetemperatur darf $T_{\text{max}} = 90^\circ\text{C}$ nicht übersteigen.

		Übersicht der Nenn Drehmomente M_{n2} [Nm]													
[i]		3	4	5	7	10	16	20	25	28	35	40	50	70	100
TQ 060		21	30	30	25	20	30	30	30	30	30	30	30	25	20
TQ 070		45	70	70	60	40	70	70	70	70	70	70	70	60	40
TQ 090		130	200	180	160	110	200	180	180	200	180	200	180	160	110
TQ 130		260	400	400	360	280	400	400	400	400	400	400	400	360	280
TQ 160		530	800	800	750	550	800	800	800	800	800	800	800	750	550

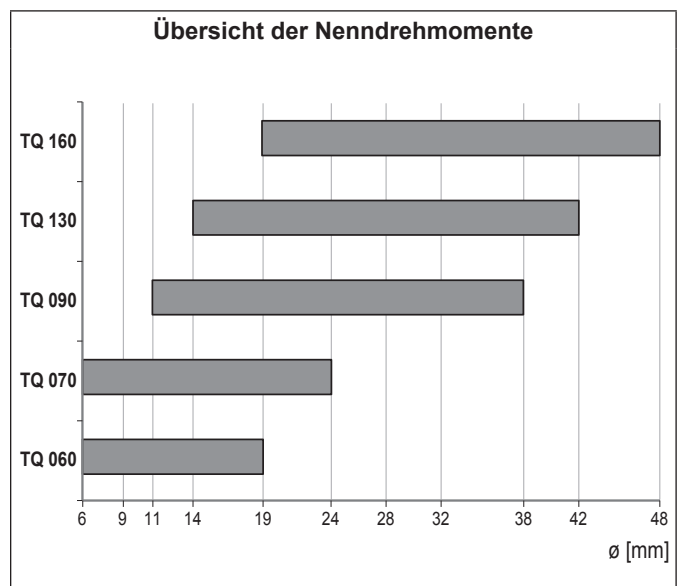
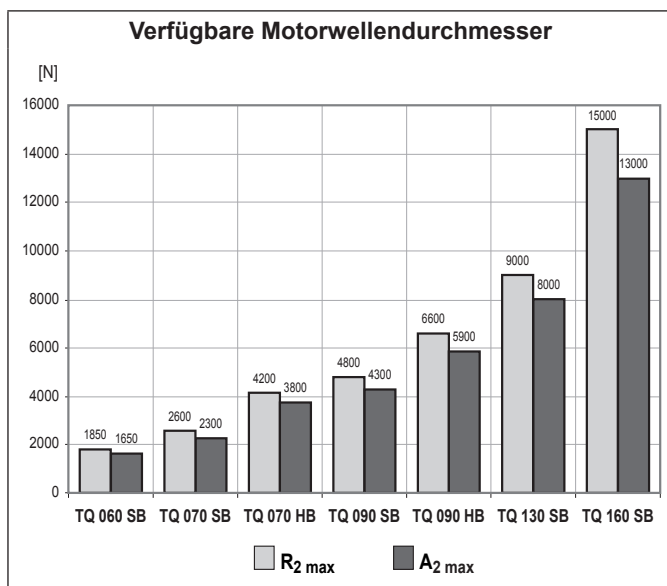

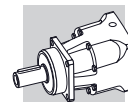

2.1 BESTELLBEZEICHNUNG

TQ

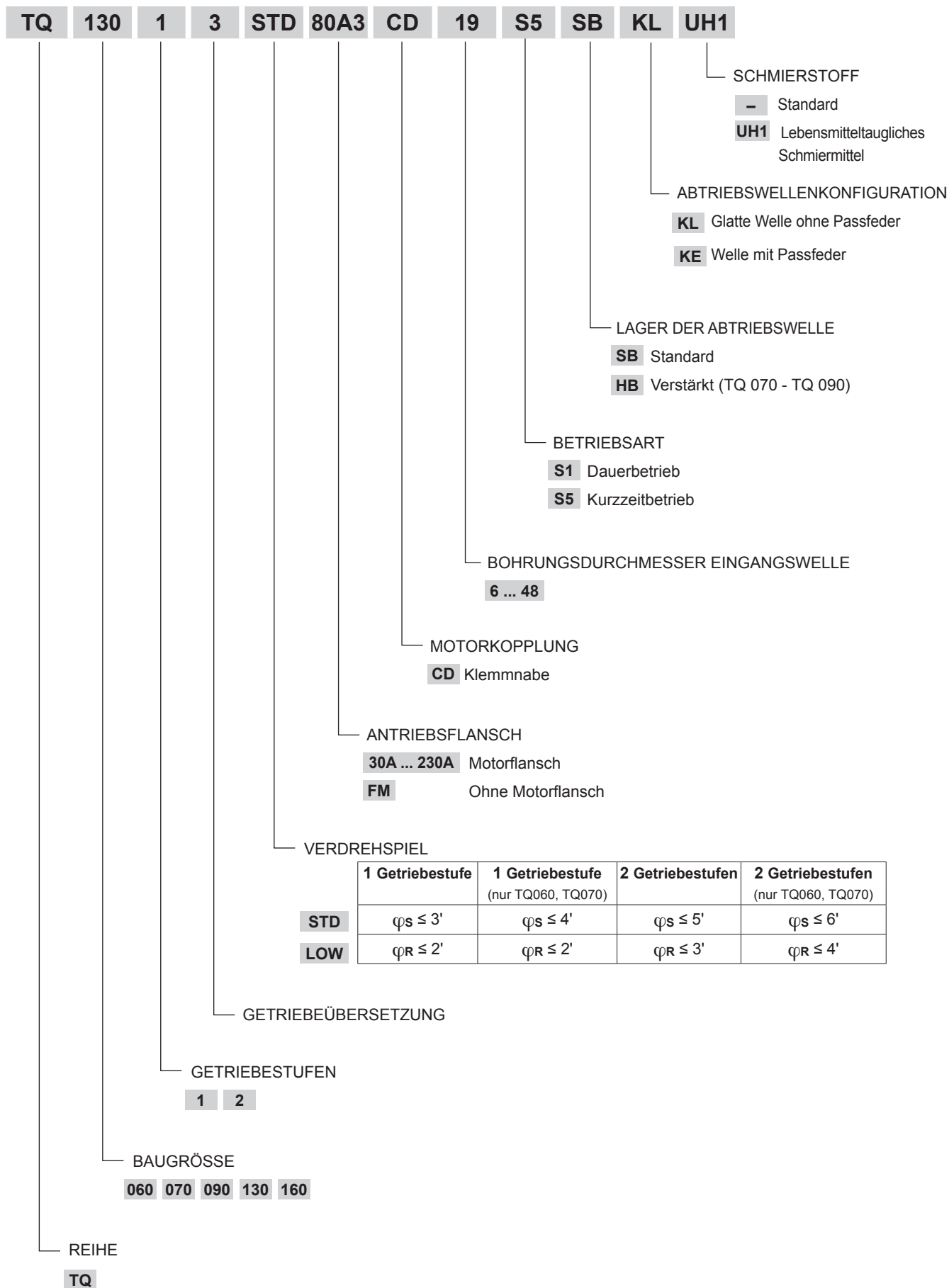

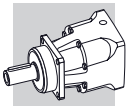

2.2 ABMESSUNGEN UND TECHNISCHE DATEN

TQ

TQ 060

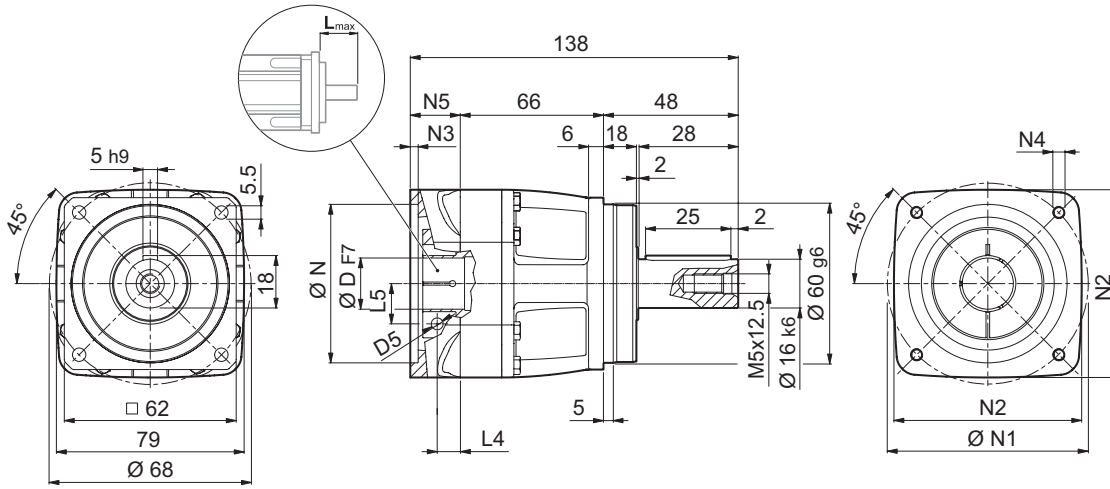

TQ 060 1	2.5

30A ... 110B0

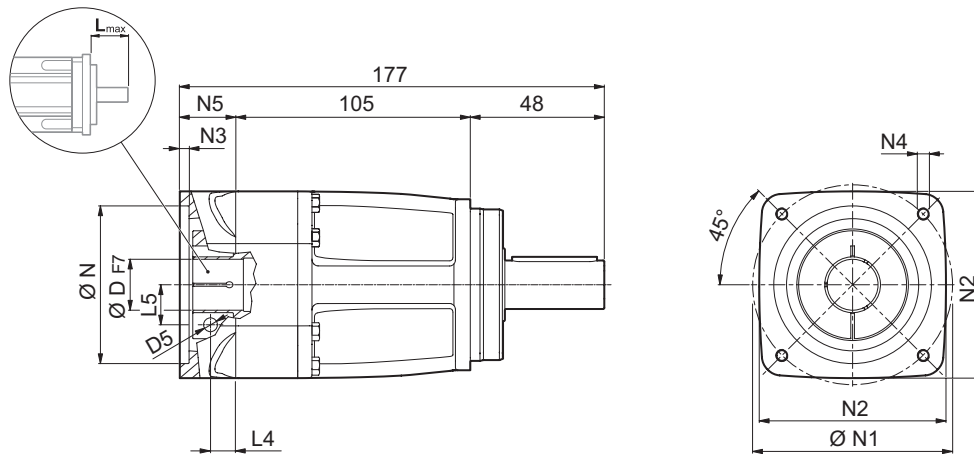

TQ 060 2	3.5

						N	N1	N2	N3	N4	N5	L _{max}
30A	6	-	-	-	-	30	46	60	3.5	M4x10	24	40
40B1	6	9	11	14	-	40	63	60	3.5	M4x10	24	40
50A1	6	9	11	14	-	50	60	60	4.0	M4x10	24	40
50C1	6	9	11	14	-	50	70	60	4.0	M4x10	24	40
60A2	6	9	11	14	19	60	75	80	4.0	M5x12	24	40
70B1	6	9	11	14	19	70	90	80	4.0	M5x12	24	40
80A1	6	9	11	14	19	80	100	100	4.0	M6x14	24	40
95A	6	9	11	14	19	95	115	100	4.0	M8x24	24	40
110B0	6	9	11	14	19	110	145	120	4.0	M8x24	24	40

Für weitere Motoradapter und Antriebswellenbohrungen bitte nachfragen.

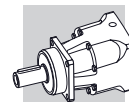

TQ 060

TQ

FM

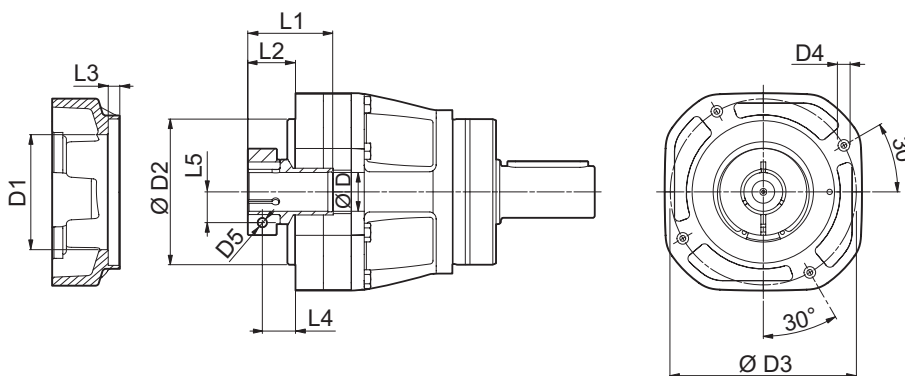

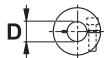
 D	D1	D2	D3	D4	D5	L1	L2	L3	L4	L5
6	37	59	72	M5x11	M4	31.5	15.5	4.5	10.5	8
9	49	59	72	M5x11	M5	35	19	4.5	11.5	10.5
11	49	59	72	M5x11	M6	35	19	4.5	11.5	12.5
14	49	59	72	M5x11	M6	35	19	4.5	11.5	14.5
19	54	59	72	M5x11	M6	35	19	4.5	11.5	16.5

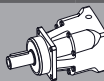
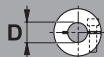
	M_{n2}	M_{a2}	M_{p2}	n_1	$n_{1\max}$	$\varphi_S \leq \varphi_R$		C_t	$R_{2\max}$	$A_{2\max}$	η	J_G [kgcm ²]		
						[arcmin]								
i	[Nm]	[Nm]	[Nm]	[min ⁻¹]	[min ⁻¹]			$\frac{Nm}{arcmin}$	[N]	[N]	%	6 - 9	11 - 14	19
TQ 060 1_3	21	32	60	3500	6000	4'	2'	4.8	1850	1650	97	0.36	0.47	0.51
TQ 060 1_4	30	45	80	3500	6000	4'	2'	4.8	1850	1650	97	0.28	0.39	0.43
TQ 060 1_5	30	45	80	3500	6000	4'	2'	4.8	1850	1650	97	0.25	0.36	0.40
TQ 060 1_7	25	38	70	4000	6000	4'	2'	4.8	1850	1650	97	0.22	0.33	0.37
TQ 060 1_10	20	30	55	4000	6000	4'	2'	4.8	1850	1650	97	0.21	0.32	0.36
TQ 060 2_16	30	45	80	4500	6000	6'	4'	4.7	1850	1650	94	0.27	0.39	0.42
TQ 060 2_20	30	45	80	4500	6000	6'	4'	4.7	1850	1650	94	0.27	0.39	0.42
TQ 060 2_25	30	45	80	4500	6000	6'	4'	4.7	1850	1650	94	0.24	0.36	0.39
TQ 060 2_28	30	45	80	4500	6000	6'	4'	4.7	1850	1650	94	0.22	0.33	0.37
TQ 060 2_35	30	45	80	4500	6000	6'	4'	4.7	1850	1650	94	0.22	0.33	0.37
TQ 060 2_40	30	45	80	4500	6000	6'	4'	4.7	1850	1650	94	0.21	0.32	0.36
TQ 060 2_50	30	45	80	4500	6000	6'	4'	4.7	1850	1650	94	0.21	0.32	0.36
TQ 060 2_70	25	38	70	5000	6000	6'	4'	4.7	1850	1650	94	0.21	0.32	0.36
TQ 060 2_100	20	30	55	5000	6000	6'	4'	4.7	1850	1650	94	0.20	0.32	0.35

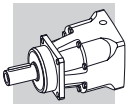

TQ 070

TQ

50C ... 130A

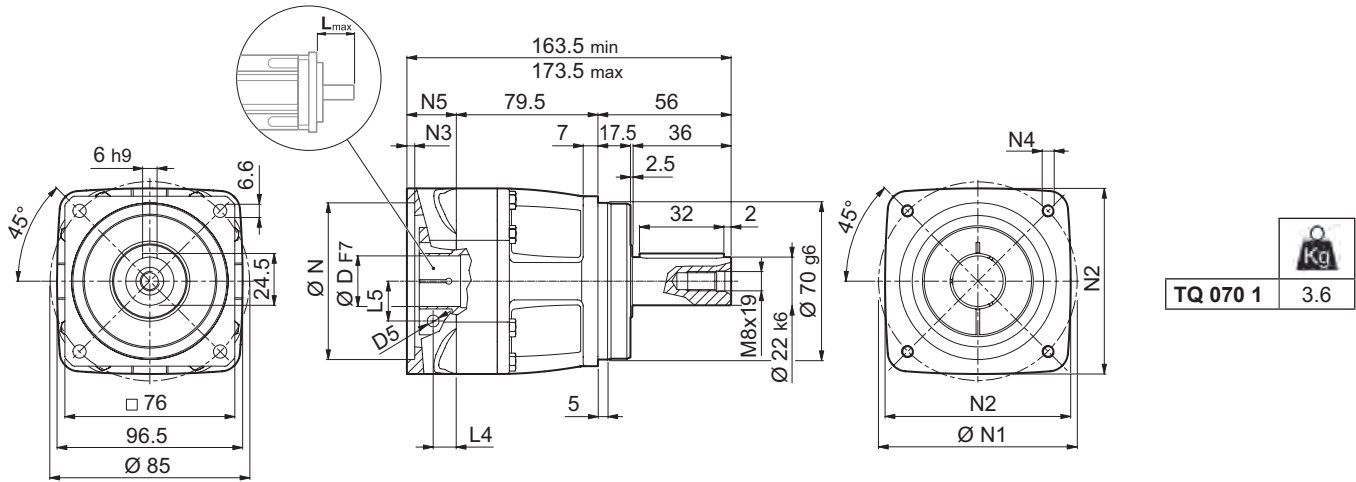

	TQ 070 1	3.6
--	-----------------	-----

30A ... 110B0

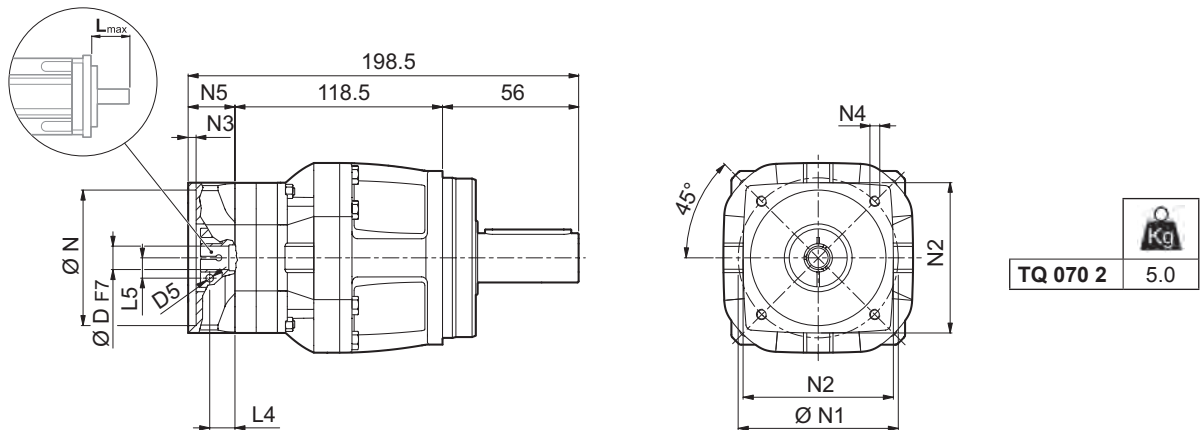

	TQ 070 2	5.0
--	-----------------	-----

							N	N1	N2	N3	N4	N5	L _{max}
	D												
TQ 070 1													
50C2	6	9	11	14	–	–	50	70	80	6.5	M4x12	28	50
60A3	6	9	11	14	19	–	60	75	80	6.5	M5x14	28	50
70B2	6	9	11	14	19	–	70	90	80	6.5	M5x14	28	50
80A2	6	9	11	14	19	–	80	100	100	6.5	M6x14	28	50
95A1	6	9	11	14	19	24	95	115	100	6.5	M8x18	28	50
110A1	6	9	11	14	19	24	110	130	120	6.5	M8x18	28	50
110B1	6	9	11	14	19	24	110	145	120	6.5	M8x20	38	60
130A	6	9	11	14	19	24	130	165	140	6.5	M10x19	28	50
TQ 070 2													
30A	6	–	–	–	–	–	30	46	60	3.5	M4x10	24	40
40B1	6	9	11	14	–	–	40	63	60	3.5	M4x10	24	40
50A1	6	9	11	14	–	–	50	60	60	4.0	M4x10	24	40
50C1	6	9	11	14	–	–	50	70	60	4.0	M4x10	24	40
60A2	6	9	11	14	19	–	60	75	80	4.0	M5x12	24	40
70B1	6	9	11	14	19	–	70	90	80	4.0	M5x12	24	40
80A1	6	9	11	14	19	–	80	100	100	4.0	M6x14	24	40
95A	6	9	11	14	19	–	95	115	100	4.0	M8x24	24	40
110B0	6	9	11	14	19	–	110	145	120	4.0	M8x24	24	40

Für weitere Motoradapter und Antriebswellenbohrungen bitte nachfragen.

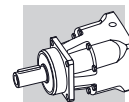

TQ 070

TQ

FM

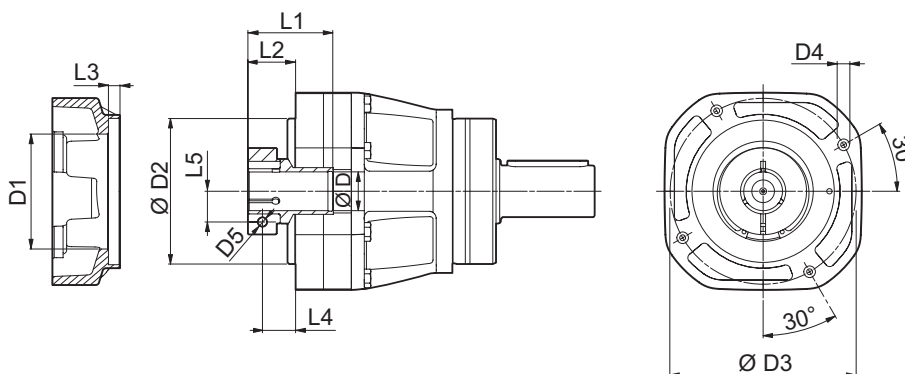

	D1	D2	D3	D4	D5	L1	L2	L3	L4	L5
TQ 070 1										
6	51	70	85	M6x11	M4	42	20	5	12.5	12.5
9	51	70	85	M6x11	M5	42	20	5	12.5	14.5
11	51	70	85	M6x11	M6	42	20	5	12.5	12.5
14	51	70	85	M6x11	M6	42	20	5	12.5	14.5
19	51	70	85	M6x11	M6	42	20	5	12.5	16.5
24	60	70	85	M6x11	M6	43.5	21.5	5	12.5	19
TQ 070 2										
6	37	59	72	M5x11	M4	31.5	15.5	4.5	10.5	8
9	49	59	72	M5x11	M5	35	19	4.5	11.5	10.5
11	49	59	72	M5x11	M6	35	19	4.5	11.5	12.5
14	49	59	72	M5x11	M6	35	19	4.5	11.5	14.5
19	54	59	72	M5x11	M6	35	19	4.5	11.5	16.5

	M_{N2}	M_{A2}	M_{P2}	n_1	$n_{1\max}$	φ_S	φ_R	C_t	SB		HB		η	J_G [kgcm ²]			
									$R_{2\max}$	$A_{2\max}$	$R_{2\max}$	$A_{2\max}$					
i	[Nm]	[Nm]	[Nm]	[min ⁻¹]	[min ⁻¹]	[arcmin]	\leq	$\left[\frac{Nm}{arcmin} \right]$	[N]	[N]	[N]	[N]	%	6 - 9	11 - 14	19	24
TQ 070 1_3	45	65	120	3000	6000	4'	2'	11.3	2600	2300	4200	3800	97	-	0.99	1.02	1.15
TQ 070 1_4	70	100	180	3000	6000	4'	2'	11.3	2600	2300	4200	3800	97	-	0.76	0.79	0.92
TQ 070 1_5	70	100	180	3000	6000	4'	2'	11.3	2600	2300	4200	3800	97	-	0.67	0.70	0.83
TQ 070 1_7	60	90	160	3500	6000	4'	2'	11.3	2600	2300	4200	3800	97	-	0.59	0.62	0.75
TQ 070 1_10	40	60	110	3500	6000	4'	2'	11.3	2600	2300	4200	3800	97	-	0.55	0.58	0.71
TQ 070 2_16	70	100	180	3500	6000	6'	4'	11.3	2600	2300	4200	3800	94	0.28	0.40	0.43	-
TQ 070 2_20	70	100	180	3500	6000	6'	4'	11.3	2600	2300	4200	3800	94	0.28	0.39	0.43	-
TQ 070 2_25	70	100	180	3500	6000	6'	4'	11.3	2600	2300	4200	3800	94	0.25	0.36	0.40	-
TQ 070 2_28	70	100	180	3500	6000	6'	4'	11.3	2600	2300	4200	3800	94	0.22	0.34	0.37	-
TQ 070 2_35	70	100	180	3500	6000	6'	4'	11.3	2600	2300	4200	3800	94	0.22	0.34	0.37	-
TQ 070 2_40	70	100	180	3500	6000	6'	4'	11.3	2600	2300	4200	3800	94	0.21	0.32	0.36	-
TQ 070 2_50	70	100	180	3500	6000	6'	4'	11.3	2600	2300	4200	3800	94	0.21	0.32	0.36	-
TQ 070 2_70	60	90	160	4000	6000	6'	4'	11.3	2600	2300	4200	3800	94	0.21	0.32	0.36	-
TQ 070 2_100	40	60	110	4500	6000	6'	4'	11.3	2600	2300	4200	3800	94	0.21	0.32	0.36	-

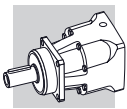

TQ 090

TQ

60A4 ... 180A1

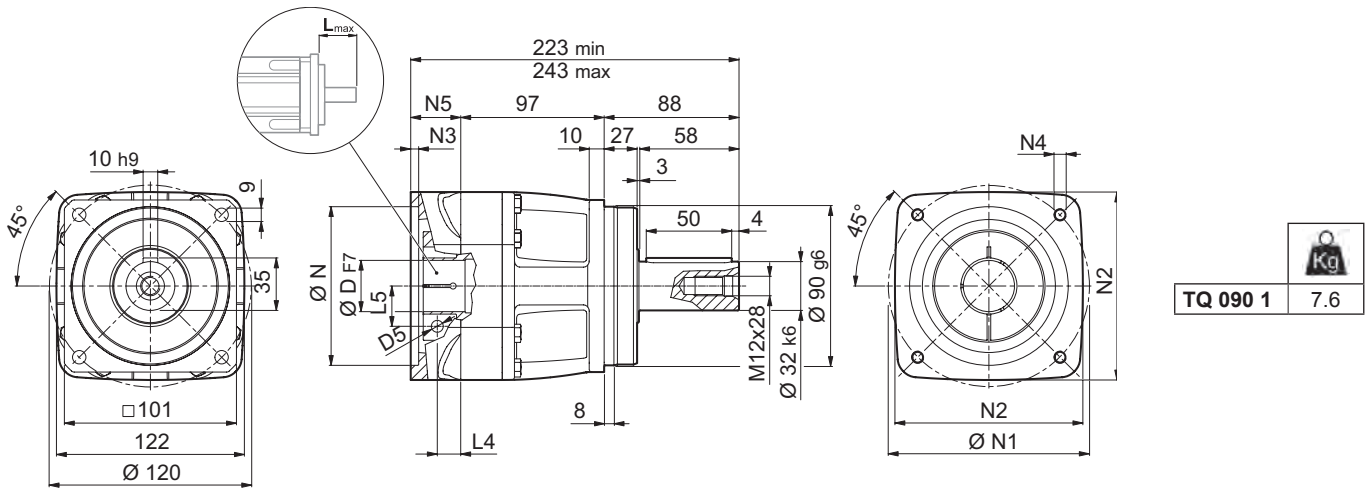

TQ 090 1 7.6

50C2 ... 130A

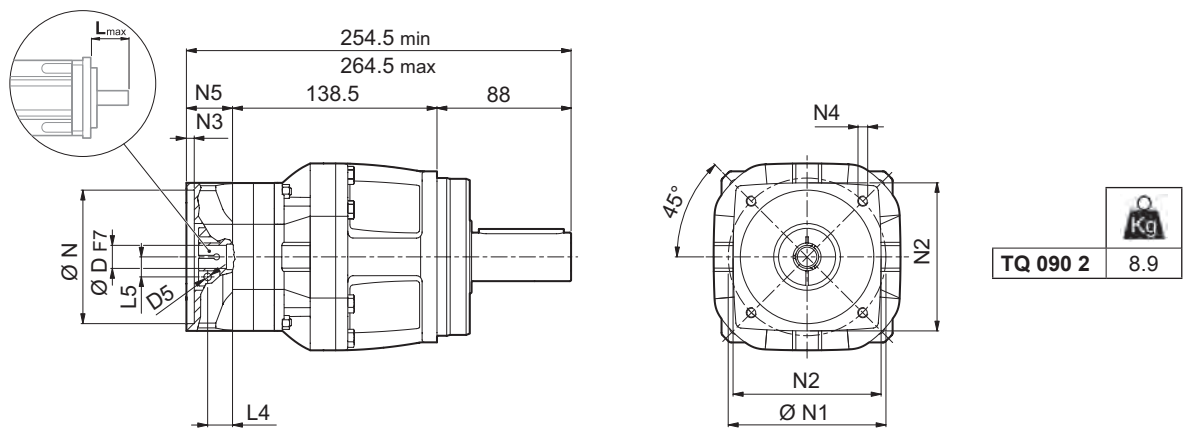

TQ 090 2 8.9

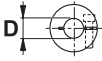
		N	N1	N2	N3	N4	N5	L _{max}
TQ 090 1								
60A4	11 14 19	- - -	60	75	100	6.5	M5x14	38 60
80A3	11 14 19	- - -	80	100	100	6.5	M6x14	38 60
95A2	11 14 19	24 28 - -	95	115	100	6.5	M8x18	38 60
110A2	11 14 19	24 - - -	110	130	122	6.5	M8x20	38 60
110B1	11 14 19	24 28 - -	110	145	122	6.5	M8x20	38 60
130A1	11 14 19	24 28 32 -	130	165	140	6.5	M10x20	38 60
180A	11 14 19	24 28 32 -	180	215	190	6.5	M14x38	38 60
180A1	11 14 19	24 28 32 38	180	215	190	6.5	M14x28	58 80
TQ 090 2								
50C2	11 14 -	- - -	50	70	80	6.5	M4x12	28 50
60A3	11 14 19	- - -	60	75	80	6.5	M5x14	28 50
70B2	11 14 19	- - -	70	90	80	6.5	M5x14	28 50
80A2	11 14 19	- - -	80	100	100	6.5	M6x14	28 50
95A1	11 14 19	24 - - -	95	115	100	6.5	M8x18	28 50
110A1	11 14 19	24 - - -	110	130	120	6.5	M8x18	28 50
110B1	11 14 19	24 - - -	110	145	120	6.5	M8x20	38 60
130A	11 14 19	24 - - -	130	165	140	6.5	M10x19	28 50

Für weitere Motoradapter und Antriebswellenbohrungen bitte nachfragen.

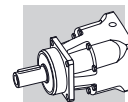

TQ 090

TQ

FM

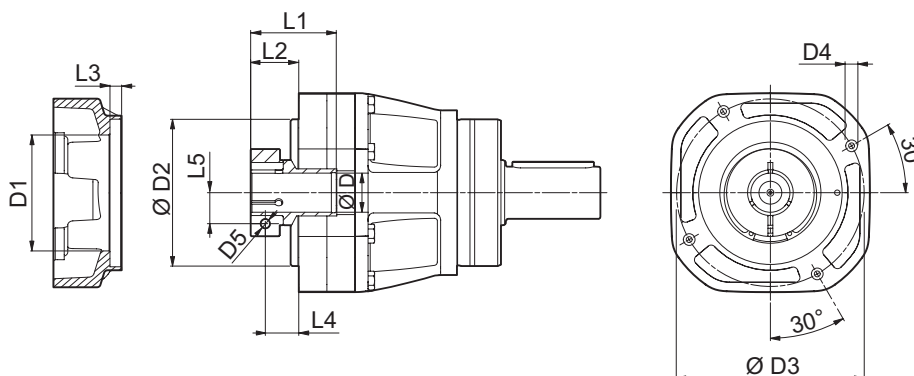

D	D1	D2	D3	D4	D5	L1	L2	L3	L4	L5
TQ 090 1										
11	51	90	115	M8x13	M6	50	28	6.5	20.5	14.5
14	51	90	115	M8x13	M6	50	28	6.5	20.5	14.5
19	51	90	115	M8x13	M6	50	28	6.5	20.5	16.5
24	60	90	115	M8x13	M6	51.5	29.5	6.5	20.5	19
28	72	90	115	M8x13	M8	51.5	29.5	6.5	20.5	22.5
32	72	90	115	M8x13	M8	51.5	29.5	6.5	20.5	24.5
38	80	90	115	M8x13	M8	51.5	29.5	6.5	20.5	28
TQ 090 2										
6	51	70	85	M6x11	M4	42	20	5	12.5	12.5
9	51	70	85	M6x11	M5	42	20	5	12.5	14.5
11	51	70	85	M6x11	M6	42	20	5	12.5	12.5
14	51	70	85	M6x11	M6	42	20	5	12.5	14.5
19	51	70	85	M6x11	M6	42	20	5	12.5	16.5
24	60	70	85	M6x11	M6	43.5	21.5	5	12.5	19

i	M _{n2} [Nm]	M _{a2} [Nm]	M _{p2} [Nm]	n ₁ [min ⁻¹]	n _{1 max} [min ⁻¹]	Φ		C _t [Nm/arcmin]	SB		HB		η	J _G [kgcm ²]				
						Φ _S	Φ _R		R _{2 max} [N]	A _{2 max} [N]	R _{2 max} [N]	A _{2 max} [N]		11	14 - 19	24	28	32-38
TQ 090 1_3	130	200	400	2500	4500	3'	2'	28	4800	4300	6600	5900	97	-	2.18	2.30	2.69	4.48
TQ 090 1_4	200	300	500	2500	4500	3'	2'	28	4800	4300	6600	5900	97	-	1.63	1.75	2.14	3.93
TQ 090 1_5	180	280	500	2500	4500	3'	2'	28	4800	4300	6600	5900	97	-	1.39	1.52	1.90	3.70
TQ 090 1_7	160	250	500	3000	4500	3'	2'	28	4800	4300	6600	5900	97	-	1.19	1.32	1.70	3.50
TQ 090 1_10	110	170	350	3000	4500	3'	2'	28	4800	4300	6600	5900	97	-	1.08	1.21	1.59	3.39
TQ 090 2_16	200	300	500	3000	4500	5'	3'	28	4800	4300	6600	5900	94	0.70	0.80	0.94	-	-
TQ 090 2_20	180	280	500	3000	4500	5'	3'	28	4800	4300	6600	5900	94	0.69	0.79	0.92	-	-
TQ 090 2_25	180	280	500	3000	4500	5'	3'	28	4800	4300	6600	5900	94	0.60	0.70	0.83	-	-
TQ 090 2_28	200	300	500	3000	4500	5'	3'	28	4800	4300	6600	5900	94	0.53	0.63	0.76	-	-
TQ 090 2_35	180	280	500	3000	4500	5'	3'	28	4800	4300	6600	5900	94	0.52	0.62	0.75	-	-
TQ 090 2_40	200	300	500	3000	4500	5'	3'	28	4800	4300	6600	5900	94	0.48	0.58	0.71	-	-
TQ 090 2_50	180	280	500	3500	4500	5'	3'	28	4800	4300	6600	5900	94	0.48	0.58	0.71	-	-
TQ 090 2_70	160	250	500	4000	4500	5'	3'	28	4800	4300	6600	5900	94	0.48	0.58	0.71	-	-
TQ 090 2_100	110	170	350	4000	4500	5'	3'	28	4800	4300	6600	5900	94	0.48	0.58	0.71	-	-

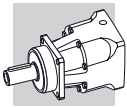

TQ 130

TQ

80A3 ... 200A

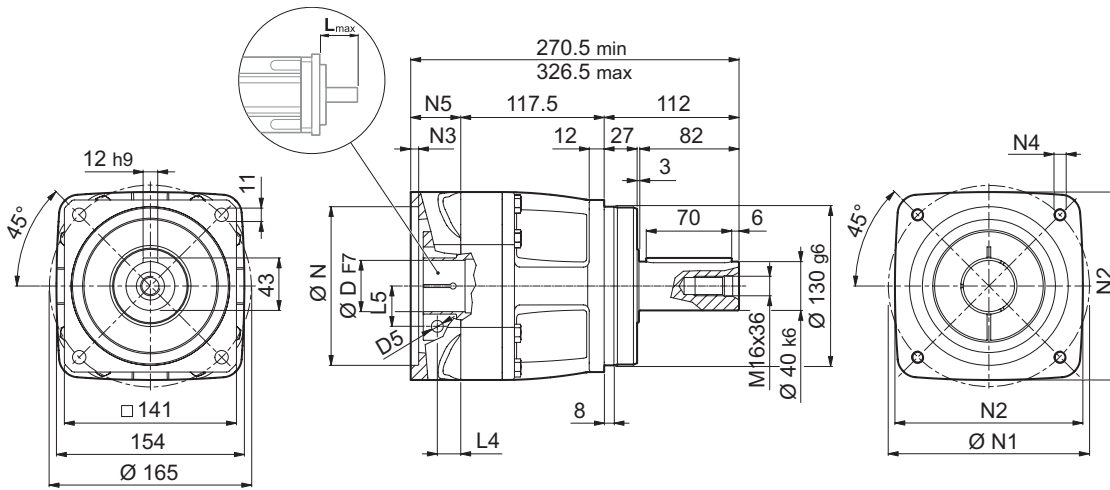

	TQ 130 1	15.6
--	-----------------	------

60A4 ... 180A1

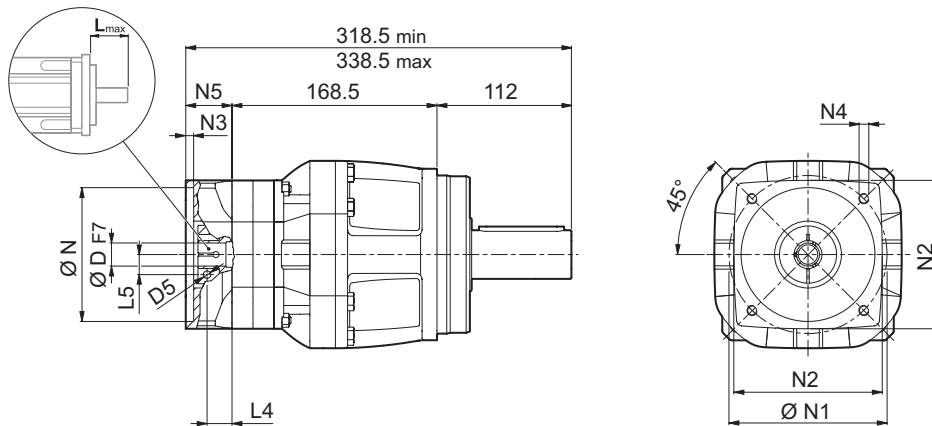

	TQ 130 2	19.1
--	-----------------	------

								N	N1	N2	N3	N4	N5	L _{max}
TQ 130 1														
80A3	14	19	-	-	-	-	-	80	100	130	6.5	M6x14	41	60
95A2	14	19	24	28	-	-	-	95	115	130	6.5	M8x18	41	60
110A2	14	19	24	-	-	-	-	110	130	130	6.5	M8x20	41	60
110B1	14	19	24	28	-	-	-	110	145	130	6.5	M8x20	41	60
130A1	14	19	24	28	32	-	-	130	165	154	6.5	M10x20	41	60
180A	14	19	24	28	32	-	-	180	215	190	6.5	M14x28	41	60
180A1	14	19	24	28	32	38	-	180	215	190	6.5	M14x28	61	80
200A	14	19	24	28	32	38	42	200	235	210	6.5	M14x28	97	110
TQ 130 2														
60A4	14	19	-	-	-	-	-	60	75	100	6.5	M5x14	38	60
80A3	14	19	-	-	-	-	-	80	100	100	6.5	M6x14	38	60
95A2	14	19	24	28	-	-	-	95	115	100	6.5	M8x18	38	60
110A2	14	19	24	-	-	-	-	110	130	122	6.5	M8x20	38	60
110B1	14	19	24	28	-	-	-	110	145	122	6.5	M8x20	38	60
130A1	14	19	24	28	32	-	-	130	165	140	6.5	M10x20	38	60
180A	14	19	24	28	32	-	-	180	215	190	6.5	M14x38	38	60
180A1	14	19	24	28	32	38	-	180	215	190	6.5	M14x28	58	80

Für weitere Motoradapter und Antriebswellenbohrungen bitte nachfragen.

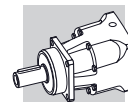



TQ 130

TQ

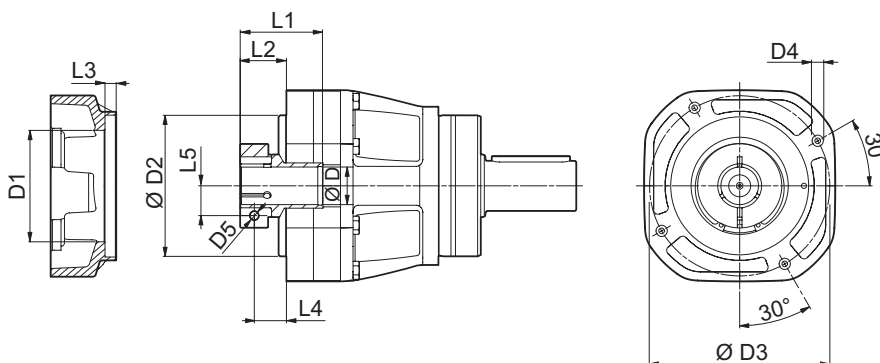
FM

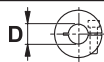

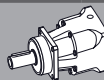
	D1	D2	D3	D4	D5	L1	L2	L3	L4	L5
TQ 130 1										
14	54	120	140	M10x16	M6	50	31	7.5	23.5	16.5
19	54	120	140	M10x16	M6	50	31	7.5	23.5	16.5
24	70	120	140	M10x16	M6	51.5	32.5	7.5	23.5	19
28	70	120	140	M10x16	M8	51.5	32.5	7.5	23.5	22.5
32	72	120	140	M10x16	M8	51.5	32.5	7.5	23.5	24.5
38	100	120	140	M10x16	M8	54	35	7.5	23.5	28
42	114	120	140	M10x16	M10	51.5	38.5	7.5	23.5	33
TQ 130 2										
11	51	90	115	M8x13	M6	50	28	6.5	20.5	14.5
14	51	90	115	M8x13	M6	50	28	6.5	20.5	14.5
19	51	90	115	M8x13	M6	50	28	6.5	20.5	16.5
24	60	90	115	M8x13	M6	51.5	29.5	6.5	20.5	19
28	72	90	115	M8x13	M8	51.5	29.5	6.5	20.5	22.5
32	72	90	115	M8x13	M8	51.5	29.5	6.5	20.5	24.5
38	80	90	115	M8x13	M8	51.5	29.5	6.5	20.5	28

	M_{n2}	M_{a2}	M_{p2}	n_1	$n_{1\max}$	$\varphi_S \leq \varphi_R$		C_t	$R_{2\max}$	$A_{2\max}$	η	J_G [kgcm ²]				
						φ_S	φ_R									
i	[Nm]	[Nm]	[Nm]	[min ⁻¹]	[min ⁻¹]	[arcmin]	[arcmin]	[Nm/arcmin]	[N]	[N]	%	14	19 - 24	28 - 32	38	42
TQ 130 1_3	260	400	900	2100	4000	3'	2'	59	9000	8000	97	-	10.02	10.48	11.12	17.12
TQ 130 1_4	400	600	1000	2100	4000	3'	2'	59	9000	8000	97	-	6.38	6.85	7.49	13.49
TQ 130 1_5	400	600	1000	2500	4000	3'	2'	59	9000	8000	97	-	5.01	5.47	6.11	12.11
TQ 130 1_7	360	550	950	2500	4000	3'	2'	59	9000	8000	97	-	3.82	4.28	4.93	10.93
TQ 130 1_10	280	420	900	2500	4000	3'	2'	59	9000	8000	97	-	3.15	3.61	4.25	10.25
TQ 130 2_16	400	600	1000	2800	4000	5'	3'	58	9000	8000	94	1.72	1.87	3.53	4.05	-
TQ 130 2_20	400	600	1000	2800	4000	5'	3'	58	9000	8000	94	1.64	1.80	3.46	3.98	-
TQ 130 2_25	400	600	1000	2800	4000	5'	3'	58	9000	8000	94	1.39	1.55	3.21	3.73	-
TQ 130 2_28	400	600	1000	2800	4000	5'	3'	58	9000	8000	94	1.20	1.36	3.02	3.54	-
TQ 130 2_35	400	600	1000	2800	4000	5'	3'	58	9000	8000	94	1.17	1.33	2.99	3.51	-
TQ 130 2_40	400	600	1000	3200	4000	5'	3'	58	9000	8000	94	1.07	1.23	2.89	3.41	-
TQ 130 2_50	400	600	1000	3200	4000	5'	3'	58	9000	8000	94	1.06	1.21	2.87	3.39	-
TQ 130 2_70	360	550	950	3500	4000	5'	3'	58	9000	8000	94	1.05	1.20	2.86	3.38	-
TQ 130 2_100	280	420	900	4000	4000	5'	3'	58	9000	8000	94	1.04	1.20	2.86	3.38	-

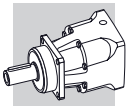

TQ 160

TQ

95A2 ... 230A

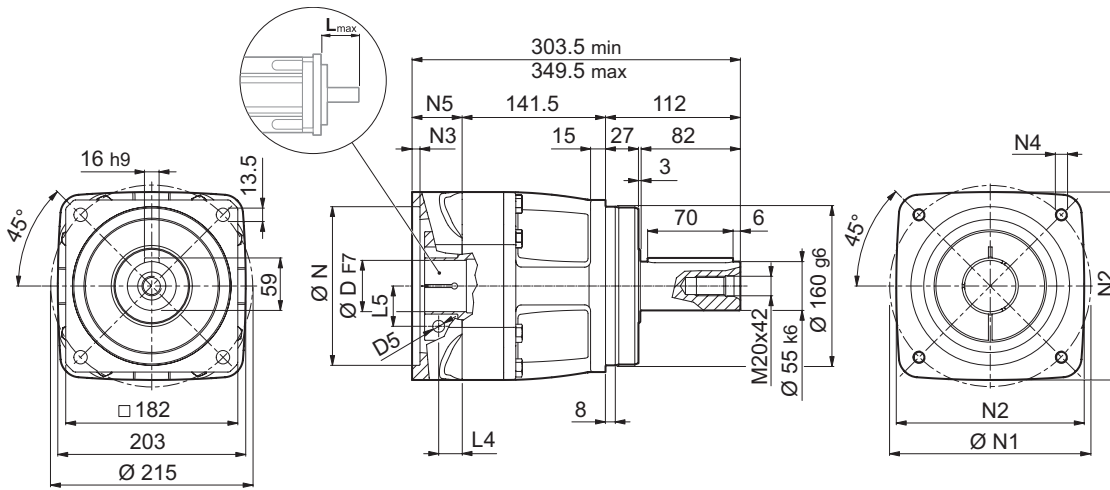

	TQ 160 1	29.7
--	-----------------	------

80A3 ... 200A

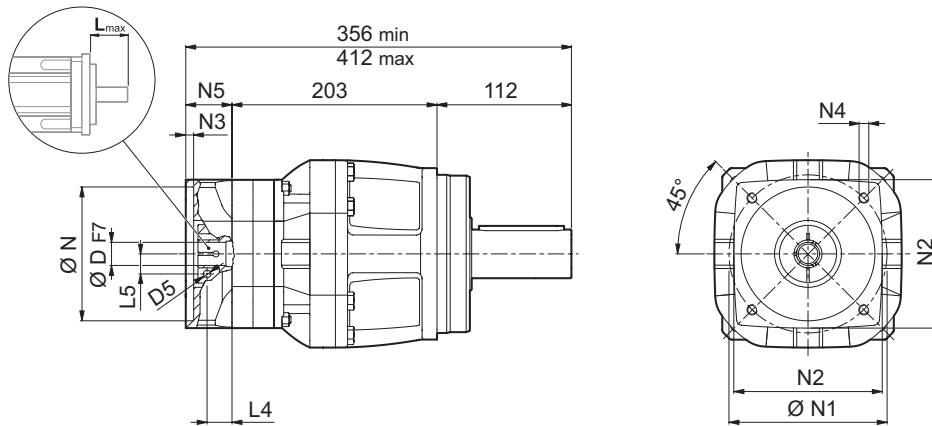

	TQ 160 2	37.4
--	-----------------	------

								N	N1	N2	N3	N4	N5	L _{max}
TQ 160 1														
95A2	19	24	28	-	-	-	-	95	115	158	6.5	M8x20	50	60
110A2	19	24	-	-	-	-	-	110	130	158	6.5	M8x20	50	60
130A1	19	24	28	32	-	-	-	130	165	158	6.5	M10x20	50	60
180A	19	24	28	32	-	-	-	180	215	203	6.5	M14x28	50	60
180A1	19	24	28	32	38	-	-	180	215	205	6.5	M14x28	60	80
200A	19	24	28	32	38	42	48	200	235	220	6.5	M14x28	96	110
230A	19	24	28	32	38	42	48	230	265	240	6.5	M14x28	96	110
TQ 160 2														
80A3	19	-	-	-	-	-	-	80	100	130	6.5	M6x14	41	60
95A2	19	24	28	-	-	-	-	95	115	130	6.5	M8x18	41	60
110A2	19	24	-	-	-	-	-	110	130	130	6.5	M8x20	41	60
110B1	19	24	28	-	-	-	-	110	145	130	6.5	M8x20	41	60
130A1	19	24	28	32	-	-	-	130	165	154	6.5	M10x20	41	60
180A	19	24	28	32	-	-	-	180	215	190	6.5	M14x28	41	60
180A1	19	24	28	32	38	-	-	180	215	190	6.5	M14x28	61	80
200A	19	24	28	32	38	42	-	200	235	210	6.5	M14x28	97	110

Für weitere Motoradapter und Antriebswellenbohrungen bitte nachfragen.

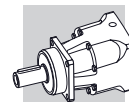

TQ 160

TQ

FM

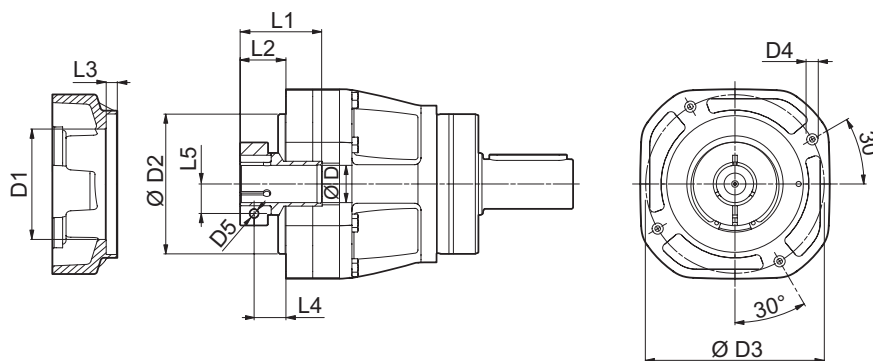

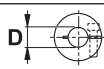
	D1	D2	D3	D4	D5	L1	L2	L3	L4	L5
TQ 160 1										
19	58	150	175	M12x20	M6	47	37	9.5	28	19
24	58	150	175	M12x20	M6	47	37	9.5	28	19
28	70	150	175	M12x20	M8	47	37	9.5	28	22.5
32	72	150	175	M12x20	M8	47	37	9.5	28	24.5
38	100	150	175	M12x20	M8	59.5	39.5	9.5	28	28
42	114	150	175	M12x20	M10	57	43	9.5	28	33
48	125	150	175	M12x20	M12	57	43	9.5	28	36.5
TQ 160 2										
14	54	120	140	M10x16	M6	50	31	7.5	23.5	16.5
19	54	120	140	M10x16	M6	50	31	7.5	23.5	16.5
24	70	120	140	M10x16	M6	51.5	32.5	7.5	23.5	19
28	70	120	140	M10x16	M8	51.5	32.5	7.5	23.5	22.5
32	72	120	140	M10x16	M8	51.5	32.5	7.5	23.5	24.5
38	100	120	140	M10x16	M8	54	35	7.5	23.5	28
42	114	120	140	M10x16	M10	51.5	38.5	7.5	23.5	33

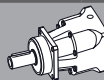
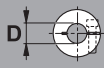
	M_{n2}	M_{a2}	M_{p2}	n_1	$n_{1\max}$	$\varphi_S \leq \varphi_R$		C_t	$R_{2\max}$	$A_{2\max}$	η	J_G [kgcm ²]				
						φ_S	φ_R									
i	[Nm]	[Nm]	[Nm]	[min ⁻¹]	[min ⁻¹]	[arcmin]	[arcmin]	[Nm/arcmin]	[N]	[N]	%	19	24 - 28	32 - 38	42	48
TQ 160 1_3	530	800	1500	1500	3500	3'	2'	170	15000	13000	97	-	29.58	29.99	32.89	45.99
TQ 160 1_4	800	1200	2000	1500	3500	3'	2'	170	15000	13000	97	-	18.03	18.44	21.33	34.44
TQ 160 1_5	800	1200	2000	1800	3500	3'	2'	170	15000	13000	97	-	11.76	12.17	15.06	28.17
TQ 160 1_7	750	1150	2000	2500	3500	3'	2'	170	15000	13000	97	-	9.27	9.68	12.58	25.68
TQ 160 1_10	550	850	1600	2500	3500	3'	2'	170	15000	13000	97	-	7.05	7.46	10.35	23.46
TQ 160 2_16	800	1200	2000	2800	3500	5'	3'	170	15000	13000	94	6.52	7.05	7.77	13.77	-
TQ 160 2_20	800	1200	2000	2800	3500	5'	3'	170	15000	13000	94	6.16	6.69	7.41	13.41	-
TQ 160 2_25	800	1200	2000	2800	3500	5'	3'	170	15000	13000	94	4.81	5.34	6.06	12.06	-
TQ 160 2_28	800	1200	2000	2800	3500	5'	3'	170	15000	13000	94	3.77	4.30	5.02	11.02	-
TQ 160 2_35	800	1200	2000	2800	3500	5'	3'	170	15000	13000	94	3.65	4.18	4.90	10.90	-
TQ 160 2_40	800	1200	2000	2800	3500	5'	3'	170	15000	13000	94	3.05	3.57	4.30	10.30	-
TQ 160 2_50	800	1200	2000	2800	3500	5'	3'	170	15000	13000	94	2.99	3.52	4.24	10.24	-
TQ 160 2_70	750	1150	2000	3000	3500	5'	3'	170	15000	13000	94	2.97	3.50	4.22	10.22	-
TQ 160 2_100	550	850	1600	3000	3500	5'	3'	170	15000	13000	94	2.95	3.48	4.20	10.20	-

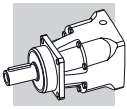

TQ



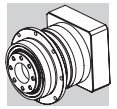

NEUE TQF-REIHE

KOAXIALE PRÄZISIONSPLANETENGETRIEBE MIT FLANSCHWELLE

Die TQF Getriebe stehen an der Spitze des Produktportfolios.
Ob Drehmoment, Steifigkeit oder Präzision – diese attraktive Produktreihe punktet in jeder Kategorie.

TQF

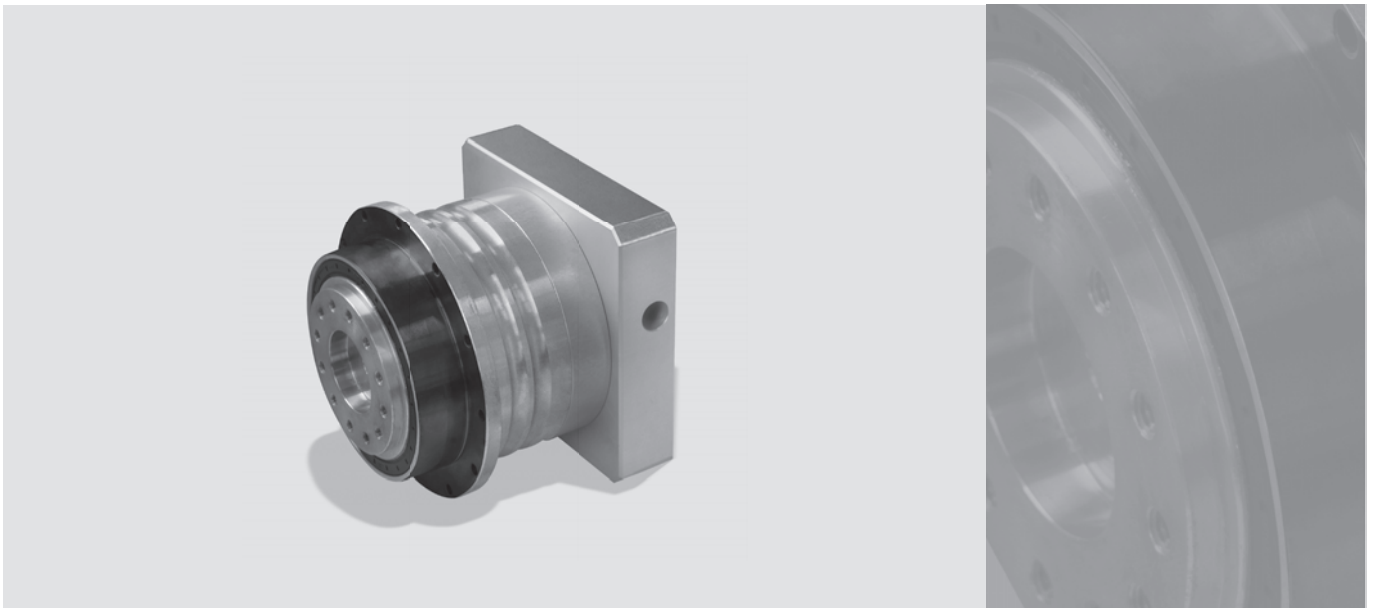

Produktmerkmale:

- Höchste Drehmomentdichte mit kompaktem Design
- Höchstes Beschleunigungs- und Nenndrehmoment
- Höchste radiale und axiale Belastbarkeit
- Höchstes Kippmoment und höchste Drehsteifigkeit
- Niedriges Verdrehflankenspiel – unter 3 arcmin
- Flanschelle ähnlich EN ISO 9409
- Entwickelt für Zyklus- und Dauerbetrieb
- Höchste Verdrehsteifigkeit
- Laufruhig
- Einsetzbar in beliebiger Montageaposition

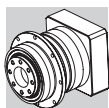

3 EIGENSCHAFTEN DER NEUEN TQF-REIHE

Die spielarmen Planetengetriebe der TQF-Reihe mit abtriebsseitiger Flanschswelle sind ideal für höchste Positioniergenauigkeit und dynamischen Zyklusbetrieb geeignet.

Entwicklung und Konstruktion folgten dem Ziel eine Produktreihe mit höchster Leistung, höchster Steifigkeit, geringem Spiel und Kompaktheit zu schaffen.

TQF

- Die TQF-Reihe hat zwei Präzisionsklassen, mit diesem Verdrehflankenspiel:
 1-stufige Getriebe: standard $\varphi_S \leq 5'$ reduziert $\varphi_R \leq 3'$
 2-stufige Getriebe: standard $\varphi_S \leq 7'$ reduziert $\varphi_R \leq 5'$
- Eine hohe IP-Schutzklasse (IP65) sorgt dafür, dass innenliegende Teile vor Staub- und Flüssigkeitseintritt geschützt sind.
- Serienmäßige Fluorelastomer-Wellendichtungen an der Eingangswelle
- Schalldruckpegel $60 \leq L_p \leq 70$ dB(A). Gemessen in 1 m Abstand ohne Last und bei einer Eingangsdrehzahl von $n_1 = 3000 \text{ min}^{-1}$; $i = 10$.
- Große Auswahl an Motoradaptoren sorgt für den Anschluss an die marktgängigsten Servomotoren.
- Schmierung optimiert für die gewünschte Betriebsart.
 Ohne Verunreinigung muss das Schmiermittel nicht regelmäßig gewechselt werden.

Betrieb	TQF 060 ... TQF 160	andere Dichtungen
S1 (kontinuierlich)	Synthetiköl Viskositätsklasse ISO VG 220	Fluorelastomer
S5 (unterbrochen)	NLGI Fettkonsistenz 00	NBR

- Umgebungstemperatur min. -20°C , max. $+30^\circ\text{C}$; bei Temperaturen höher als 30°C ist der Temperaturfaktor f_T zu berücksichtigen..
- Die Gehäusetemperatur darf $T_{\text{max}} = 90^\circ\text{C}$ nicht übersteigen.

		Übersicht der Nenn Drehmomente M_{n2} [Nm]												
[i]		4	5	7	10	16	20	25	28	35	40	50	70	100
TQF 060		30	30	25	20	30	30	30	30	30	30	30	25	20
TQF 070		70	70	60	40	70	70	70	70	70	70	70	60	40
TQF 090		200	180	160	110	200	180	180	200	180	200	180	160	110
TQF 130		400	400	360	280	400	400	400	400	400	400	400	360	280
TQF 160		800	800	750	550	800	800	800	800	800	800	800	750	550

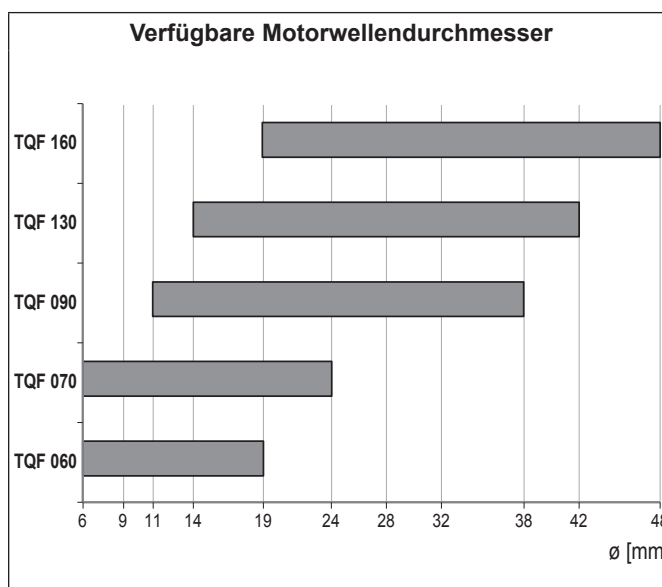
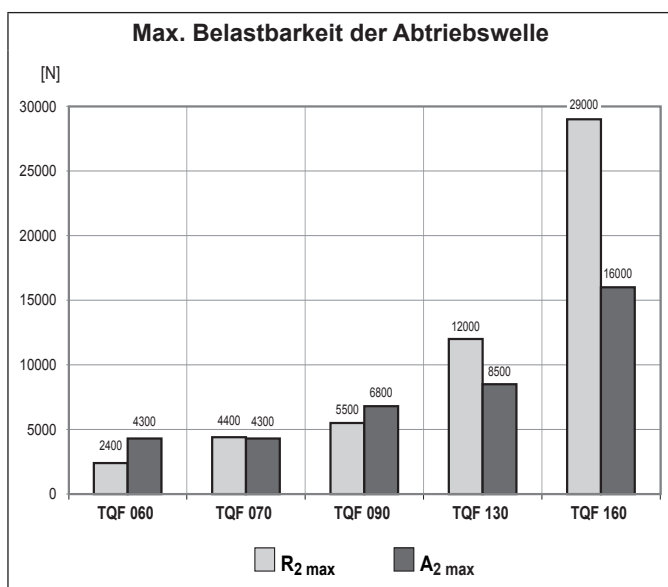

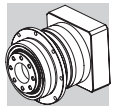

3.1 BESTELLBEZEICHNUNG

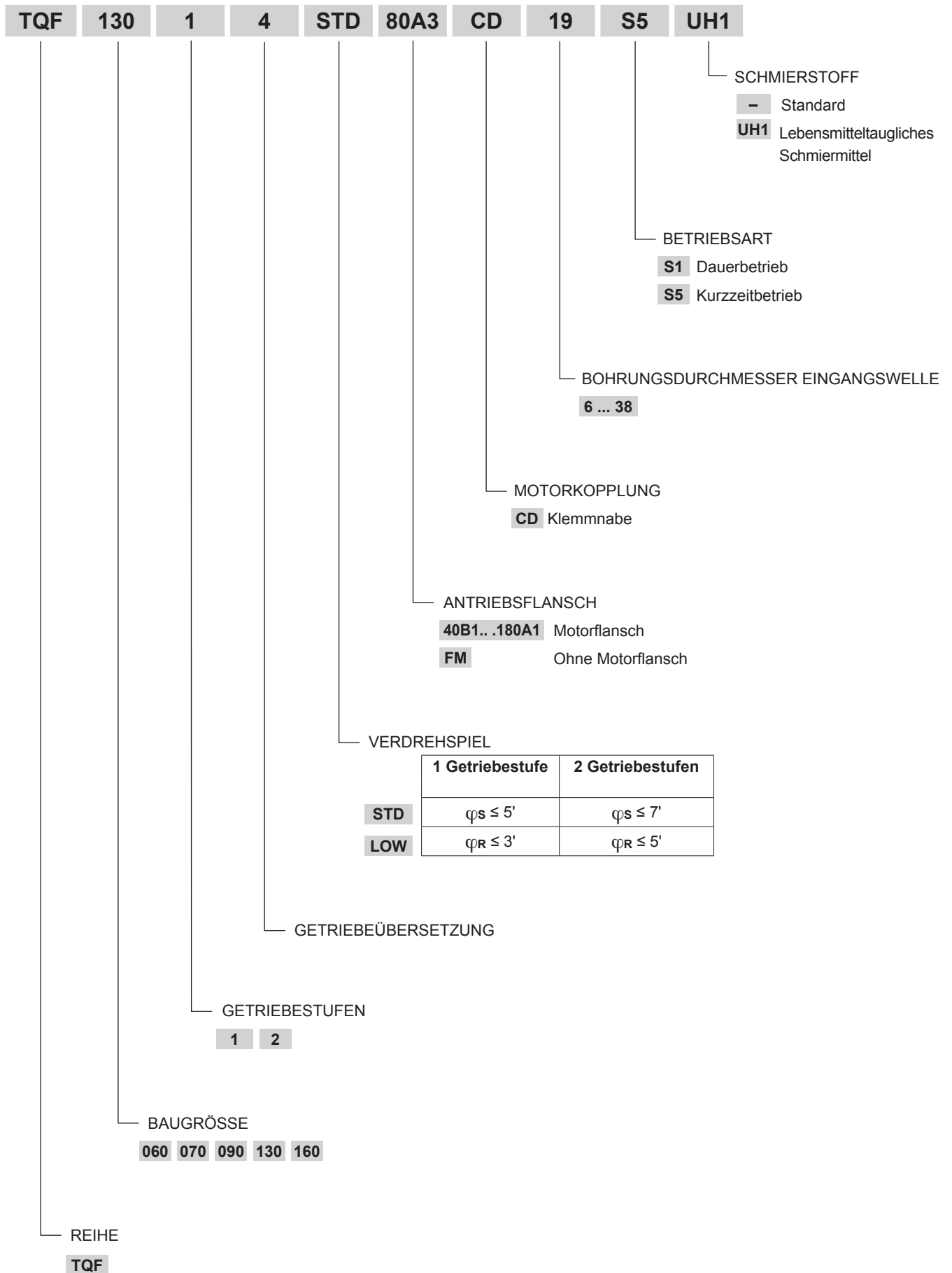

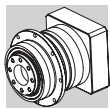

3.2 ABMESSUNGEN UND TECHNISCHE DATEN

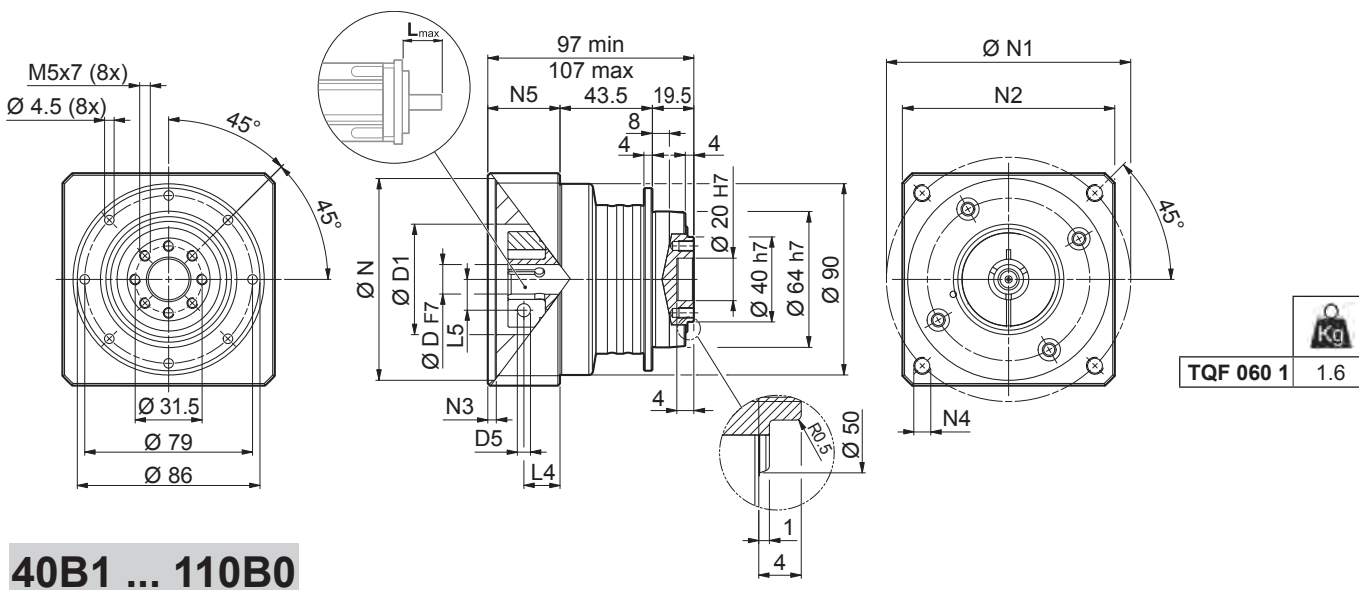

TQF 060

TQF

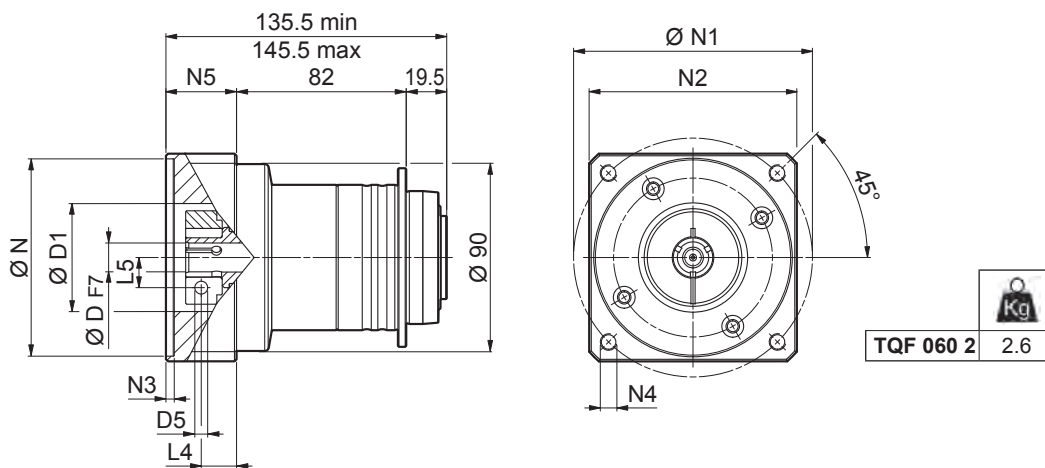

40B1 ... 110B0



						N	N1	N2	N3	N4	N5	L _{max}
40B1	6	9	11	14	-	40	63	80	4	M4x12	34	40
50A1	6	9	11	14	-	50	60	80	4	M4x10	34	40
50C1	6	9	11	14	-	50	70	80	4	M4x10	34	40
60A2	6	9	11	14	19	60	75	80	4	M5x16	34	40
70B1	6	9	11	14	19	70	90	80	4	M5x16	34	40
80A1	6	9	11	14	19	80	100	90	4	M6x16	34	40
95A	6	9	11	14	19	95	115	100	6.5	M8x20	34	40
110B0	6	9	11	14	19	110	145	120	6.5	M8x20	44	40

Für weitere Motoradapter und Antriebswellenbohrungen bitte nachfragen.

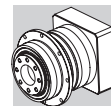

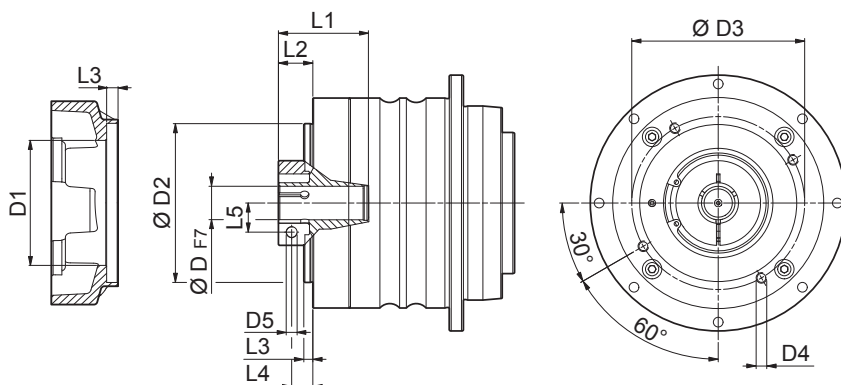

TQF 060

FM

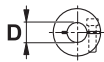

TQF

	D1	D2	D3	D4	D5	L1	L2	L3	L4	L5
6	37	68	76.5	M6x12	M4	31.5	21.5	7.5	16	8
9	49	68	76.5	M6x12	M5	35	24.5	7.5	17	10.5
11	49	68	76.5	M6x12	M6	35	24.5	7.5	17	12.5
14	49	68	76.5	M6x12	M6	35	24.5	7.5	17	14.5
19	54	68	76.5	M6x12	M6	35	24.5	7.5	17	16.5

	i	M _{n 2}	M _{a 2}	M _{p 2}	n ₁	n _{1 max}	φ _S	φ _R	C _t	R _{2 max}	A _{2 max}	η	J _G [kgcm ²]		
		[Nm]	[Nm]	[Nm]	[min ⁻¹]	[min ⁻¹]	[arcmin]	[Nm/arcmin]	[N]	[N]	%		6 - 9	11 - 14	19
TQF 060 1_4		30	45	80	3500	6000	5'	3'	12	2400	4300	97	0.32	0.43	0.47
TQF 060 1_5		30	45	80	3500	6000	5'	3'	12	2400	4300	97	0.27	0.39	0.42
TQF 060 1_7		25	38	70	4000	6000	5'	3'	12	2400	4300	97	0.23	0.35	0.38
TQF 060 1_10		20	30	55	4000	6000	5'	3'	12	2400	4300	97	0.21	0.33	0.36
TQF 060 2_16		30	45	80	4500	6000	7'	5'	12	2400	4300	94	0.28	0.39	0.43
TQF 060 2_20		30	45	80	4500	6000	7'	5'	12	2400	4300	94	0.27	0.39	0.42
TQF 060 2_25		30	45	80	4500	6000	7'	5'	12	2400	4300	94	0.25	0.36	0.40
TQF 060 2_28		30	45	80	4500	6000	7'	5'	12	2400	4300	94	0.22	0.34	0.37
TQF 060 2_35		30	45	80	4500	6000	7'	5'	12	2400	4300	94	0.22	0.33	0.37
TQF 060 2_40		30	45	80	4500	6000	7'	5'	12	2400	4300	94	0.21	0.32	0.36
TQF 060 2_50		30	45	80	4500	6000	7'	5'	12	2400	4300	94	0.21	0.32	0.36
TQF 060 2_70		25	38	70	5000	6000	7'	5'	12	2400	4300	94	0.21	0.32	0.36
TQF 060 2_100		20	30	55	5000	6000	7'	5'	12	2400	4300	94	0.21	0.32	0.36

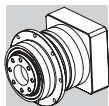

TQF 070

50C2 ... 130A

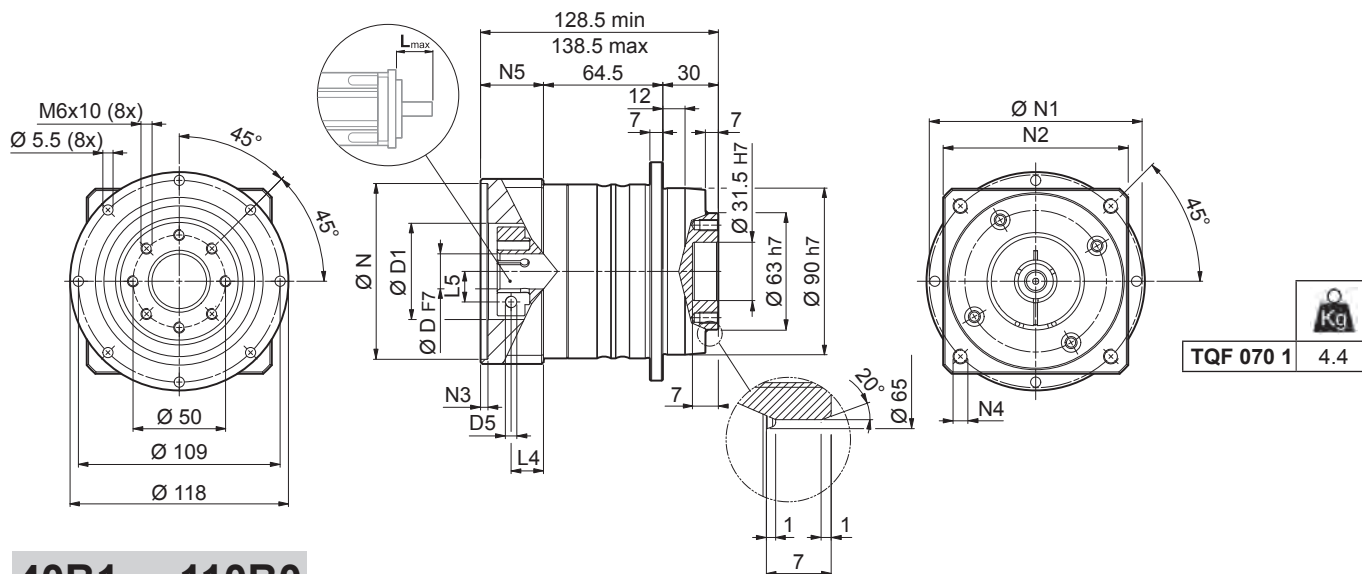

40B1 ... 110B0

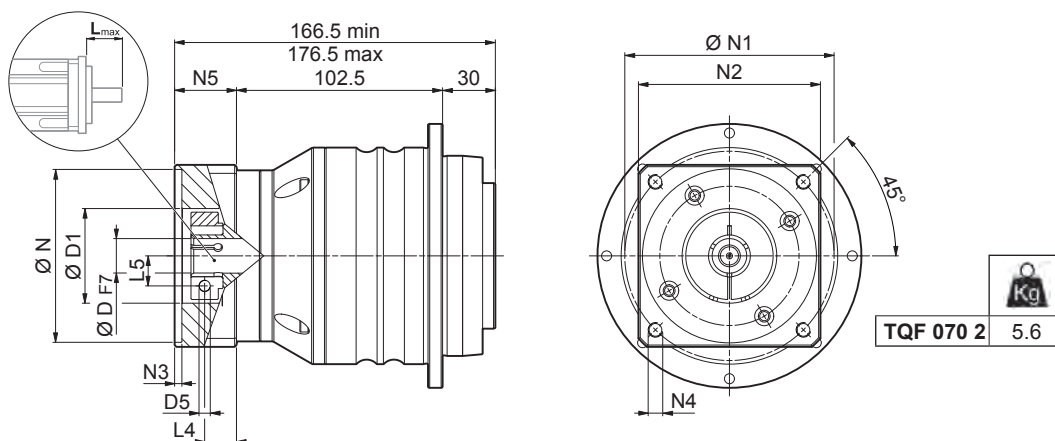

Icon	D						N	N1	N2	N3	N4	N5	L _{max}
	1	2	3	4	5	6							
TQF 070 1													
50C2	6	9	11	14	-	-	50	70	80	4	M4x10	34	50
60A3	6	9	11	14	19	-	60	75	80	4	M5x16	34	50
70B2	6	9	11	14	19	-	70	90	80	4	M5x16	34	50
80A2	6	9	11	14	19	-	80	100	90	4	M6x16	34	50
95A1	6	9	11	14	19	24	95	115	100	6.5	M8x20	34	50
110A1	6	9	11	14	19	24	110	130	115	6.5	M8x20	34	50
110B1	6	9	11	14	19	24	110	145	120	6.5	M8x20	44	60
130A	6	9	11	14	19	24	130	165	140	6.5	M10x19	34	50
TQF 070 2													
40B1	6	9	11	14	-	-	40	63	80	4	M4x12	34	40
50A1	6	9	11	14	-	-	50	60	80	4	M4x10	34	40
50C1	6	9	11	14	-	-	50	70	80	4	M4x10	34	40
60A2	6	9	11	14	19	-	60	75	80	4	M5x16	34	40
70B1	6	9	11	14	19	-	70	90	80	4	M5x16	34	40
80A1	6	9	11	14	19	-	80	100	90	4	M6x16	34	40
95A	6	9	11	14	19	-	95	115	100	6.5	M8x20	34	40
110B0	6	9	11	14	19	-	110	145	120	6.5	M8x20	44	40

Für weitere Motoradapter und Antriebswellenbohrungen bitte nachfragen.

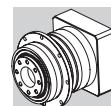

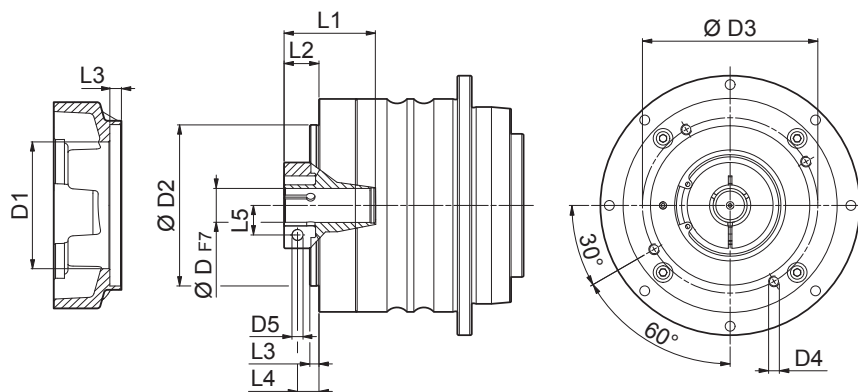

TQF 070

FM



TQF

	D1	D2	D3	D4	D5	L1	L2	L3	L4	L5
TQF 070 1										
6	37	68	76.5	M6x14	M4	45	23	9	19	8
9	49	68	76.5	M6x14	M5	42	26	9	18.5	10.5
11	51	68	76.5	M6x14	M6	42	25	9	17.5	12.5
14	51	68	76.5	M6x14	M6	42	25	9	17.5	14.5
19	51	68	76.5	M6x14	M6	42	25	9	17.5	16.5
24	60	68	76.5	M6x14	M6	43.5	26.5	9	17.5	19
TQF 070 2										
6	37	68	76.5	M6x12	M4	31.5	21.5	7.5	16	8
9	49	68	76.5	M6x12	M5	35	24.5	7.5	17	10.5
11	49	68	76.5	M6x12	M6	35	24.5	7.5	17	12.5
14	49	68	76.5	M6x12	M6	35	24.5	7.5	17	14.5
19	54	68	76.5	M6x12	M6	35	24.5	7.5	17	16.5

	M_{n2}	M_{a2}	M_{p2}	n_1	n_{1max}	φ_S	φ_R	C_t	R_{2max}	A_{2max}	η	J_G [kgcm ²]			
												D	6 - 9	11 - 14	19
	[Nm]	[Nm]	[Nm]	[min ⁻¹]	[min ⁻¹]	[arcmin]	\leq	$\left[\frac{Nm}{arcmin} \right]$	[N]	[N]	%				
TQF 070 1_4	70	100	180	3000	6000	5'	3'	29	4400	4300	97	-	1.05	1.09	1.22
TQF 070 1_5	70	100	180	3000	6000	5'	3'	29	4400	4300	97	-	0.85	0.88	1.01
TQF 070 1_7	60	90	160	3500	6000	5'	3'	29	4400	4300	97	-	0.68	0.71	0.85
TQF 070 1_10	40	60	110	3500	6000	5'	3'	29	4400	4300	97	-	0.59	0.62	0.75
TQF 070 2_16	70	100	180	3500	6000	7'	5'	29	4400	4300	94	0.31	0.43	0.46	-
TQF 070 2_20	70	100	180	3500	6000	7'	5'	29	4400	4300	94	0.30	0.41	0.45	-
TQF 070 2_25	70	100	180	3500	6000	7'	5'	29	4400	4300	94	0.26	0.37	0.41	-
TQF 070 2_28	70	100	180	3500	6000	7'	5'	29	4400	4300	94	0.23	0.35	0.38	-
TQF 070 2_35	70	100	180	3500	6000	7'	5'	29	4400	4300	94	0.23	0.34	0.38	-
TQF 070 2_40	70	100	180	3500	6000	7'	5'	29	4400	4300	94	0.21	0.33	0.36	-
TQF 070 2_50	70	100	180	3500	6000	7'	5'	29	4400	4300	94	0.21	0.32	0.36	-
TQF 070 2_70	60	90	160	4000	6000	7'	5'	29	4400	4300	94	0.21	0.32	0.36	-
TQF 070 2_100	40	60	110	4500	6000	7'	5'	29	4400	4300	94	0.21	0.32	0.36	-

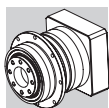

TQF 090

60A4 ... 180A

TQF

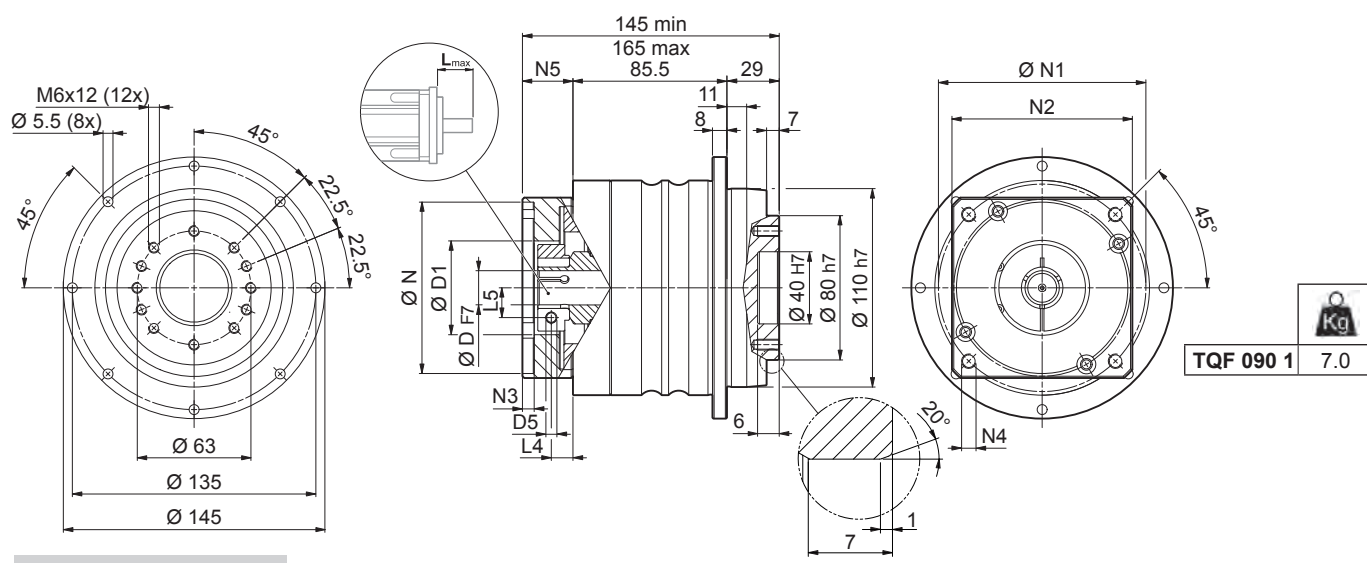

50C2 ... 130A

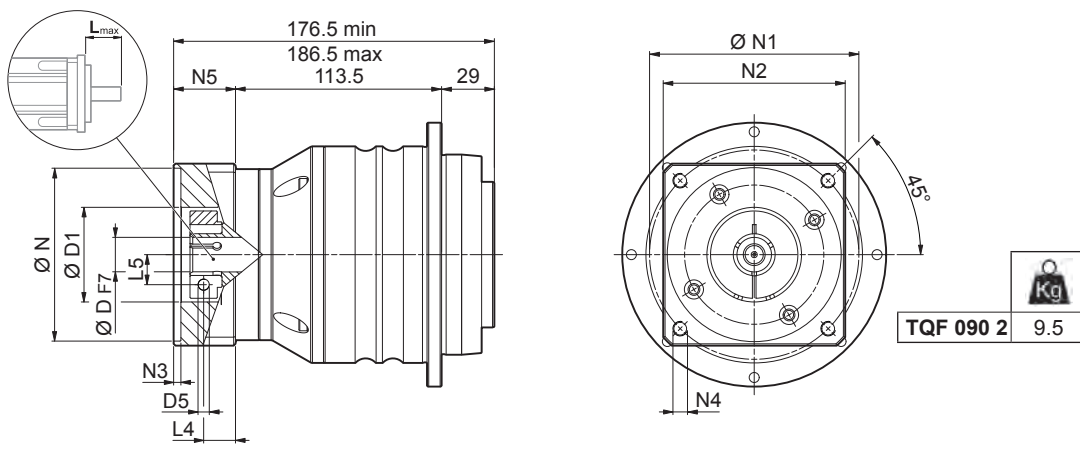

	D						N	N1	N2	N3	N4	N5	L _{max}
TQF 090 1													
60A4	11	14	19	-	-	-	60	75	100	6.5	M5x14	28	60
80A3	11	14	19	-	-	-	80	100	100	6.5	M6x16	28	60
95A2	11	14	19	24	28	-	95	115	100	6.5	M8x18	28	60
110A2	11	14	19	24	-	-	110	130	115	6.5	M8x18	28	60
110B1	11	14	19	24	28	-	110	145	120	6.5	M8x20	38	60
130A1	11	14	19	24	28	32	130	165	140	6.5	M10x25	38	60
180A	11	14	19	24	28	32	180	215	190	6.5	M14x28	48	80
TQF 090 2													
50C2	11	14	-	-	-	-	50	70	80	4	M4x10	34	50
60A3	11	14	19	-	-	-	60	75	80	4	M5x16	34	50
70B2	11	14	19	-	-	-	70	90	80	4	M5x16	34	50
80A2	11	14	19	-	-	-	80	100	90	4	M6x16	34	50
95A1	11	14	19	24	-	-	95	115	100	6.5	M8x20	34	50
110A1	11	14	19	24	-	-	110	130	115	6.5	M8x20	34	50
110B1	11	14	19	24	-	-	110	145	120	6.5	M8x20	44	60
130A	11	14	19	24	-	-	130	165	140	6.5	M10x19	34	50

Für weitere Motoradapter und Antriebswellenbohrungen bitte nachfragen.

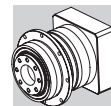

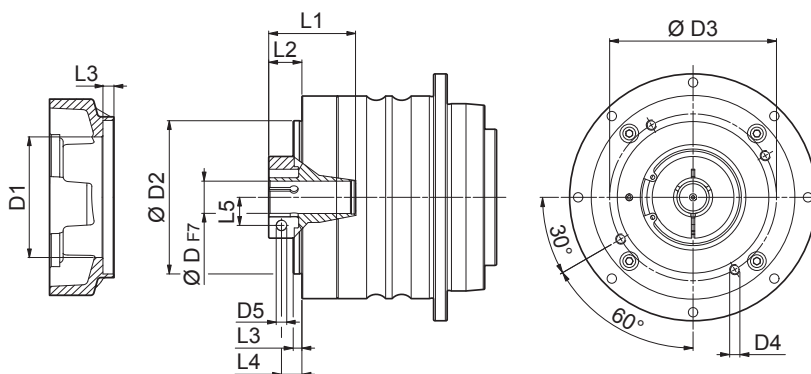

TQF 090

FM



TQF

	D1	D2	D3	D4	D5	L1	L2	L3	L4	L5
TQF 090 1										
11	49	90	98	M6x12	M6	50	17	4	9.5	12.5
14	51	90	98	M6x12	M6	50	17	4	9.5	14.5
19	51	90	98	M6x12	M6	50	17	4	9.5	16.5
24	60	90	98	M6x12	M6	51.5	18.5	4	9.5	19
28	72	90	98	M6x12	M8	51.5	18.5	4	9.5	22.5
32	72	90	98	M6x12	M8	51.5	18.5	5	12	24.5
38	80	90	98	M6x12	M8	51.5	18.5	5	12	28
TQF 090 2										
6	37	68	76.5	M6x14	M4	45	23	9	19	8
9	49	68	76.5	M6x14	M5	42	26	9	18.5	10.5
11	51	68	76.5	M6x14	M6	42	25	9	17.5	12.5
14	51	68	76.5	M6x14	M6	42	25	9	17.5	14.5
19	51	68	76.5	M6x14	M6	42	25	9	17.5	16.5
24	60	68	76.5	M6x14	M6	43.5	25	9	17.5	19

	M_{n2}	M_{a2}	M_{p2}	n_1	$n_{1\max}$	φ_S	φ_R	C_t	$R_{2\max}$	$A_{2\max}$	η	J_G [kgm ²]				
												i	[Nm]	[Nm]	[Nm]	[min ⁻¹]
TQF 090 1_4	200	300	500	2500	4500	5'	3'	70	5500	6800	97	-	2,00	2.12	2.51	4,30
TQF 090 1_5	180	280	500	2500	4500	5'	3'	70	5500	6800	97	-	1.63	1.76	2.14	3.94
TQF 090 1_7	160	250	500	3000	4500	5'	3'	70	5500	6800	97	-	1.31	1.44	1.82	3.62
TQF 090 1_10	110	170	350	3000	4500	5'	3'	70	5500	6800	97	-	1.14	1.27	1.65	3.45
TQF 090 2_16	200	300	500	3000	4500	7'	5'	70	5500	6800	94	0.75	0.85	0.98	-	-
TQF 090 2_20	180	280	500	3000	4500	7'	5'	70	5500	6800	94	0.72	0.82	0.96	-	-
TQF 090 2_25	180	280	500	3000	4500	7'	5'	70	5500	6800	94	0.62	0.72	0.85	-	-
TQF 090 2_28	200	300	500	3000	4500	7'	5'	70	5500	6800	94	0.54	0.64	0.77	-	-
TQF 090 2_35	180	280	500	3000	4500	7'	5'	70	5500	6800	94	0.53	0.63	0.76	-	-
TQF 090 2_40	200	300	500	3000	4500	7'	5'	70	5500	6800	94	0.49	0.59	0.72	-	-
TQF 090 2_50	180	280	500	3500	4500	7'	5'	70	5500	6800	94	0.48	0.58	0.72	-	-
TQF 090 2_70	160	250	500	4000	4500	7'	5'	70	5500	6800	94	0.48	0.58	0.71	-	-
TQF 090 2_100	110	170	350	4000	4500	7'	5'	70	5500	6800	94	0.48	0.58	0.71	-	-

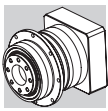

TQF 130

80A3 ... 180A1

TQF

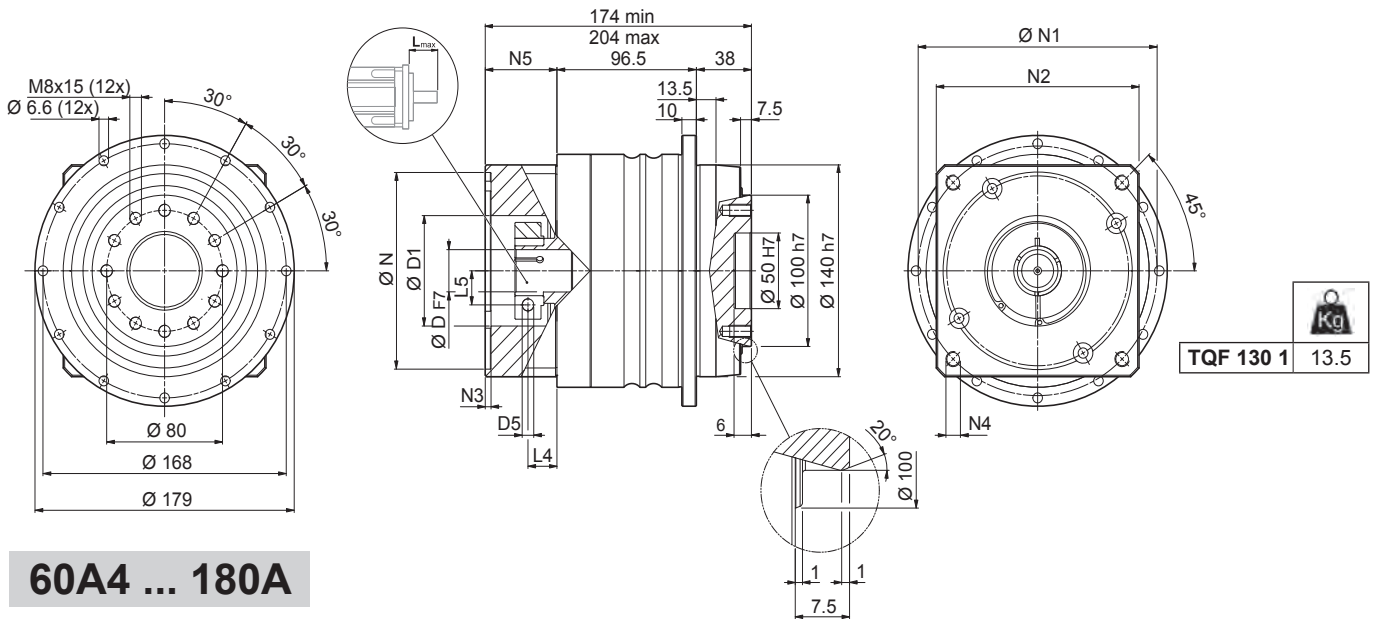

60A4 ... 180A

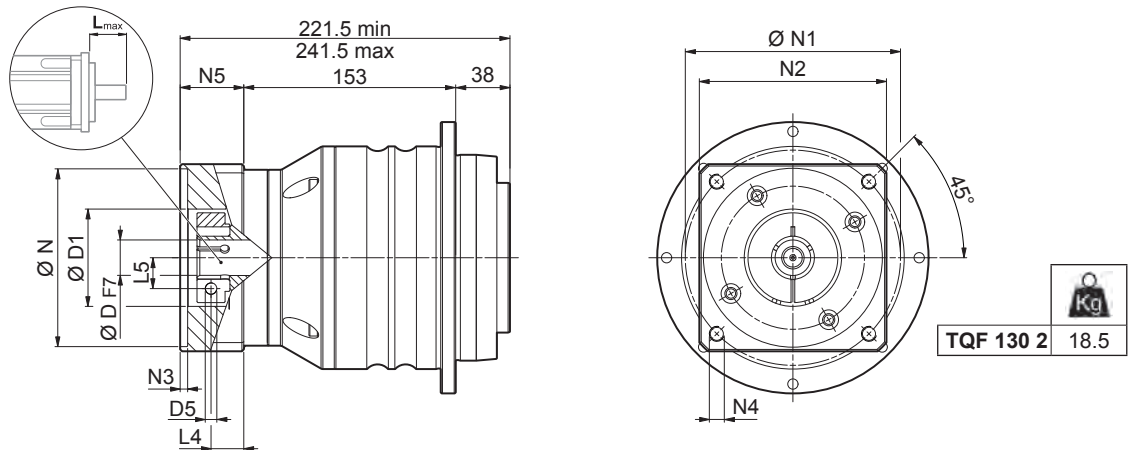

	D						N	N1	N2	N3	N4	N5	L _{max}
TQF 130 1													
80A3	14	19	-	-	-	-	80	100	130	4	M6x15	39.5	60
95A2	14	19	24	28	-	-	95	115	130	6.5	M8x20	39.5	60
110A2	14	19	24	-	-	-	110	130	130	4	M8x20	39.5	60
110B1	14	19	24	28	-	-	110	145	130	6.5	M8x20	49.5	60
130A1	14	19	24	28	32	-	130	165	140	4	M10x20	39	60
180A	14	19	24	28	32	38	180	215	190	5.5	M14x25	49.5	60
180A1	14	19	24	28	32	38	180	215	190	5.5	M14x25	69.5	80
TQF 130 2													
60A4	14	19	-	-	-	-	60	75	100	6.5	M5x14	28	60
80A3	14	19	-	-	-	-	80	100	100	6.5	M6x16	28	60
95A2	14	19	24	28	-	-	95	115	100	6.5	M8x18	28	60
110A2	14	19	24	-	-	-	110	130	115	6.5	M8x18	28	60
110B1	14	19	24	28	-	-	110	145	120	6.5	M8x20	38	60
130A1	14	19	24	28	32	-	130	165	140	6.5	M10x25	38	60
180A	14	19	24	28	32	-	180	215	190	6.5	M14x28	48	80

Für weitere Motoradapter und Antriebswellenbohrungen bitte nachfragen.

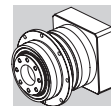

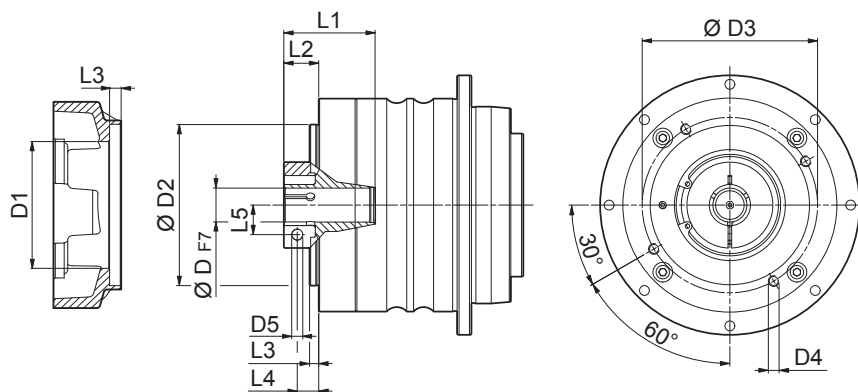

TQF 130

FM

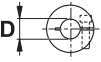

TQF

	D1	D2	D3	D4	D5	L1	L2	L3	L4	L5
TQF 130 1										
14	51	113	125.5	M8x16	M6	50	30.5	5	23	14.5
19	54	113	125.5	M8x16	M6	50	27.5	5	20	16.5
24	70	113	125.5	M8x16	M6	51.5	29	5	20	19
28	70	113	125.5	M8x16	M8	51.5	29	5	20	22.5
32	72	113	125.5	M8x16	M8	51.5	29	5	20	24.5
38	100	113	125.5	M8x16	M8	54	31.5	5	20	28
42	114	113	125.5	M8x16	M10	51.5	35	5	20	33
TQF 130 2										
11	49	90	98	M6x12	M6	50	17	4	9.5	12.5
14	51	90	98	M6x12	M6	50	17	4	9.5	14.5
19	51	90	98	M6x12	M6	50	17	4	9.5	16.5
24	60	90	98	M6x12	M6	51.5	18.5	4	9.5	19
28	72	90	98	M6x12	M8	51.5	18.5	4	9.5	22.5
32	72	90	98	M6x12	M8	51.5	18.5	5	12	24.5
38	80	90	98	M6x12	M8	51.5	18.5	5	12	28

	M_{n2}	M_{a2}	M_{p2}	n_1	$n_{1\max}$	$\varphi_S \leq \varphi_R$		C_t	$R_{2\max}$	$A_{2\max}$	η	J_G [kgcm ²]				
						[Nm]	[Nm]					[Nm]	[min ⁻¹]	[min ⁻¹]	[arcmin]	[$\frac{Nm}{arcmin}$]
TQF 130 1_4	400	600	1000	2100	4000	5'	3'	180	12000	8500	97	-	8.14	8.61	9.25	15.25
TQF 130 1_5	400	600	1000	2500	4000	5'	3'	180	12000	8500	97	-	6.13	6.59	7.24	13.24
TQF 130 1_7	360	550	950	2500	4000	5'	3'	180	12000	8500	97	-	4,40	4.86	5,50	11,50
TQF 130 1_10	280	420	900	2500	4000	5'	3'	180	12000	8500	97	-	3.43	3.89	4.53	10.53
TQF 130 2_16	400	600	1000	2800	4000	7'	5'	180	12000	8500	94	1.89	2.05	3.71	3.71	-
TQF 130 2_20	400	600	1000	2800	4000	7'	5'	180	12000	8500	94	1.77	1.92	3.58	3.58	-
TQF 130 2_25	400	600	1000	2800	4000	7'	5'	180	12000	8500	94	1.47	1.63	3.29	3.29	-
TQF 130 2_28	400	600	1000	2800	4000	7'	5'	180	12000	8500	94	1.26	1.41	3.07	3.07	-
TQF 130 2_35	400	600	1000	2800	4000	7'	5'	180	12000	8500	94	1.22	1.37	3.03	3.03	-
TQF 130 2_40	400	600	1000	3200	4000	7'	5'	180	12000	8500	94	1,10	1.25	2.91	2.91	-
TQF 130 2_50	400	600	1000	3200	4000	7'	5'	180	12000	8500	94	1.08	1.23	2.89	2.89	-
TQF 130 2_70	360	550	950	3500	4000	7'	5'	180	12000	8500	94	1.06	1.22	2.88	2.88	-
TQF 130 2_100	280	420	900	4000	4000	7'	5'	180	12000	8500	94	1.05	1.21	2.87	2.87	-

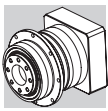

TQF 160

95A2 ... 180A1

TQF

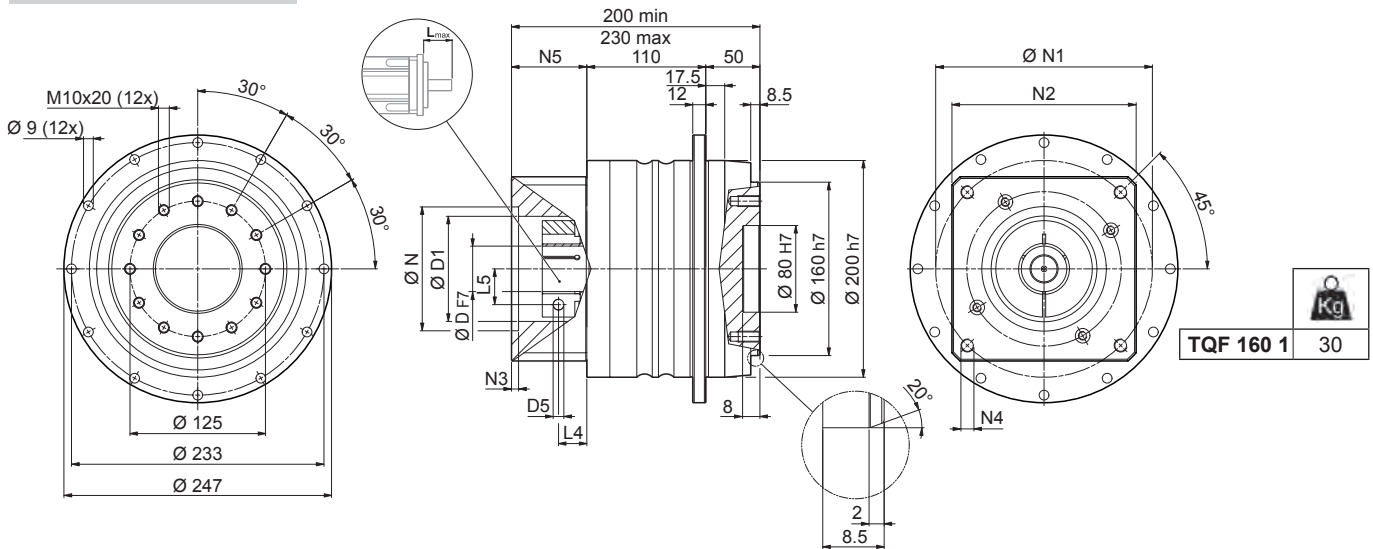

80A3 ... 180A1

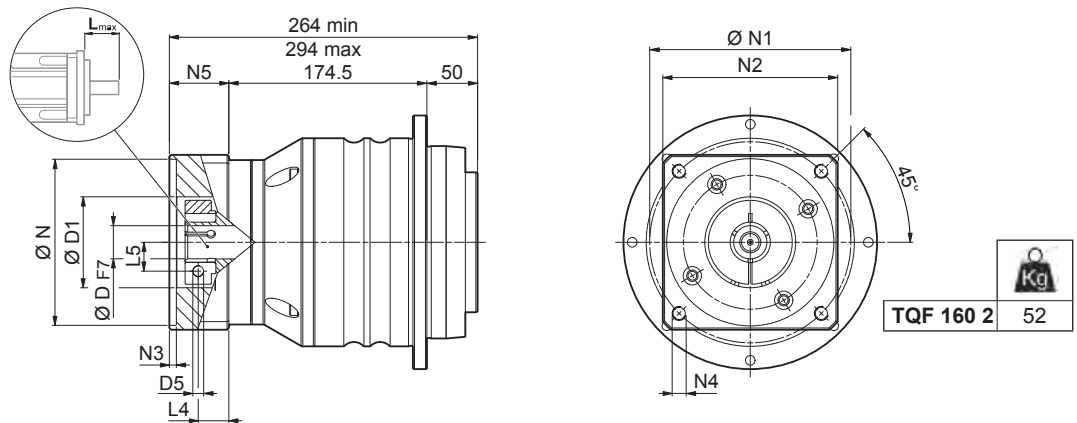

	D					N	N1	N2	N3	N4	N5	L _{max}
TQF 160 1												
95A2	19	24	28	-	-	95	115	140	6.5	M8x20	39.5	60
110A2	19	24	-	-	-	110	130	140	5	M8x20	39.5	60
130A1	19	24	28	32	-	130	165	140	5	M10x20	39.5	60
180A	-	24	28	32	-	180	215	190	6.5	M14x25	49.5	60
180A1	19	24	28	32	38	180	215	190	6.5	M14x25	69.5	80
TQF 160 2												
80A3	19	-	-	-	-	80	100	130	4	M6x15	39.5	60
95A2	19	24	28	-	-	95	115	130	6.5	M8x20	39.5	60
110A2	19	24	-	-	-	110	130	130	4	M8x20	39.5	60
110B1	19	24	28	-	-	110	145	130	6.5	M8x20	49.5	60
130A1	19	24	28	32	-	130	165	140	4	M10x20	39	60
180A	19	24	28	32	-	180	215	190	5.5	M14x25	49.5	60
180A1	19	24	28	32	38	180	215	190	5.5	M14x25	69.5	80

Für weitere Motoradapter und Antriebswellenbohrungen bitte nachfragen.

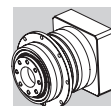

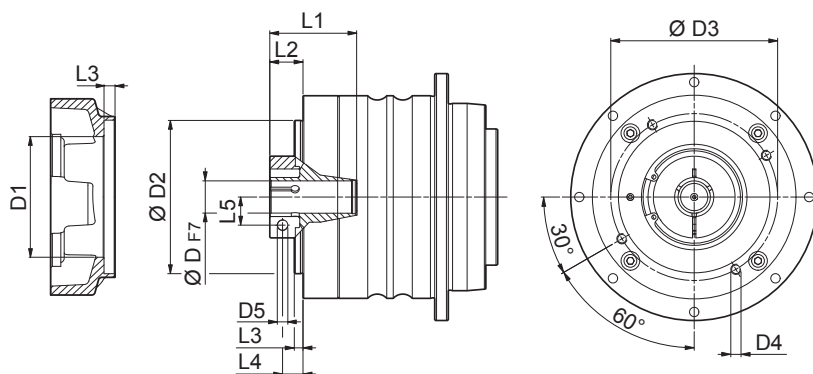

TQF 160

FM



TQF

	D1	D2	D3	D4	D5	L1	L2	L3	L4	L5
TQF 160 1										
19	54	130	142.5	M8x16	M6	47	33.5	8	26	16.5
24	58	130	142.5	M8x16	M6	47	35	8	26	19
28	70	130	142.5	M8x16	M8	47	35	8	26	22.5
32	72	130	142.5	M8x16	M8	47	35	8	26	24.5
38	100	130	142.5	M8x16	M8	59.5	37.5	8	26	28
42	114	130	142.5	M8x16	M10	57	41	8	26	33
48	125	130	142.5	M8x16	M12	57	41	8	26	36.5
TQF 160 2										
14	51	113	125.5	M8x16	M6	50	30.5	5	23	14.5
19	54	113	125.5	M8x16	M6	50	27.5	5	20	16.5
24	70	113	125.5	M8x16	M6	51.5	29	5	20	19
28	70	113	125.5	M8x16	M8	51.5	29	5	20	22.5
32	72	113	125.5	M8x16	M8	51.5	29	5	20	24.5
38	100	113	125.5	M8x16	M8	54	31.5	5	20	28
42	114	113	125.5	M8x16	M10	51.5	35	5	20	33

	M_{n2}	M_{a2}	M_{p2}	n_1	$n_{1\max}$	φ_s	φ_R	C_t	$R_{2\max}$	$A_{2\max}$	η	J_G [kgcm ²]						
												\leq	$\left[\frac{Nm}{arcmin} \right]$	[N]	[N]	%	19	24 - 28
i	[Nm]	[Nm]	[Nm]	[min ⁻¹]	[min ⁻¹]	[arcmin]												
TQF 160 1_4	800	1200	2000	1500	3500	5'	3'	500	29000	16000	97	-	27,10	27,51	30,40	43,51		
TQF 160 1_5	800	1200	2000	1800	3500	5'	3'	500	29000	16000	97	-	18,22	18,63	21,52	34,63		
TQF 160 1_7	750	1150	2000	2500	3500	5'	3'	500	29000	16000	97	-	13,46	13,87	16,77	29,88		
TQF 160 1_10	550	850	1600	2500	3500	5'	3'	500	29000	16000	97	-	10,03	10,44	13,34	26,45		
TQF 160 2_16	800	1200	2000	2800	3500	7'	5'	500	29000	16000	94	7,22	7,75	8,47	14,47	-		
TQF 160 2_20	800	1200	2000	2800	3500	7'	5'	500	29000	16000	94	6,67	7,20	7,92	13,92	-		
TQF 160 2_25	800	1200	2000	2800	3500	7'	5'	500	29000	16000	94	5,13	5,66	6,38	12,38	-		
TQF 160 2_28	800	1200	2000	2800	3500	7'	5'	500	29000	16000	94	4,00	4,53	5,25	11,25	-		
TQF 160 2_35	800	1200	2000	2800	3500	7'	5'	500	29000	16000	94	3,82	4,34	5,07	11,07	-		
TQF 160 2_40	800	1200	2000	2800	3500	7'	5'	500	29000	16000	94	3,16	3,69	4,41	10,41	-		
TQF 160 2_50	800	1200	2000	2800	3500	7'	5'	500	29000	16000	94	3,07	3,60	4,32	10,32	-		
TQF 160 2_70	750	1150	2000	3000	3500	7'	5'	500	29000	16000	94	3,02	3,55	4,27	10,27	-		
TQF 160 2_100	550	850	1600	3000	3500	7'	5'	500	29000	16000	94	2,99	3,52	4,24	10,24	-		

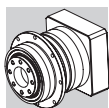

TQF

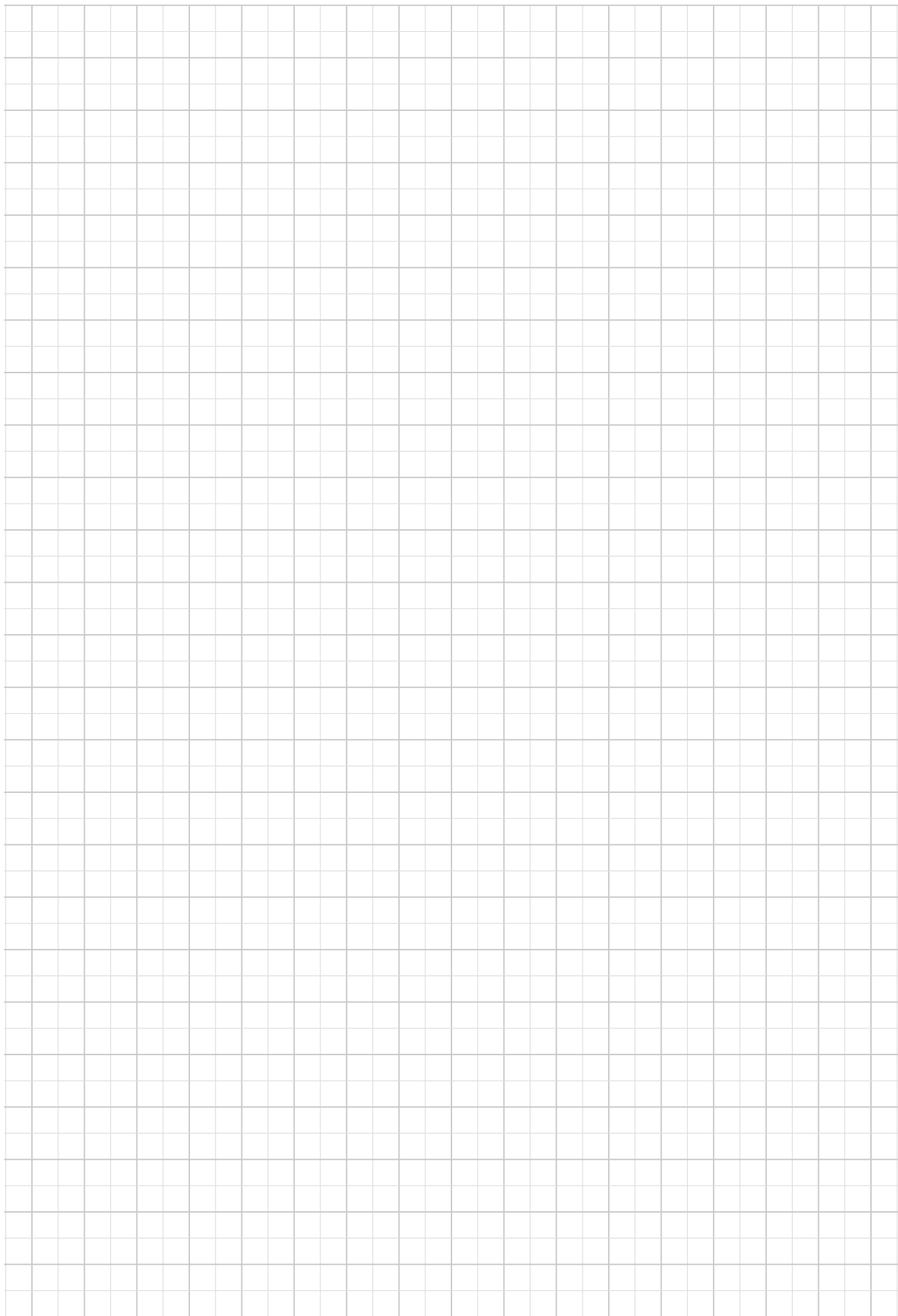

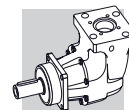

TQK

ABGEWINKELTES PRÄZISIONSPLANETENGETRIEBE

Die TQK Getriebe stehen wie die TQ Getriebe an der Spitze des Produktportfolios.

Dieses Getriebe ist die Lösung bei Platzproblemen, die die immer kompakteren Maschinen aufwerfen.

Ob Drehmoment, Steifigkeit oder Präzision – diese attraktive Produktreihe punktet in jeder Kategorie.

TQK

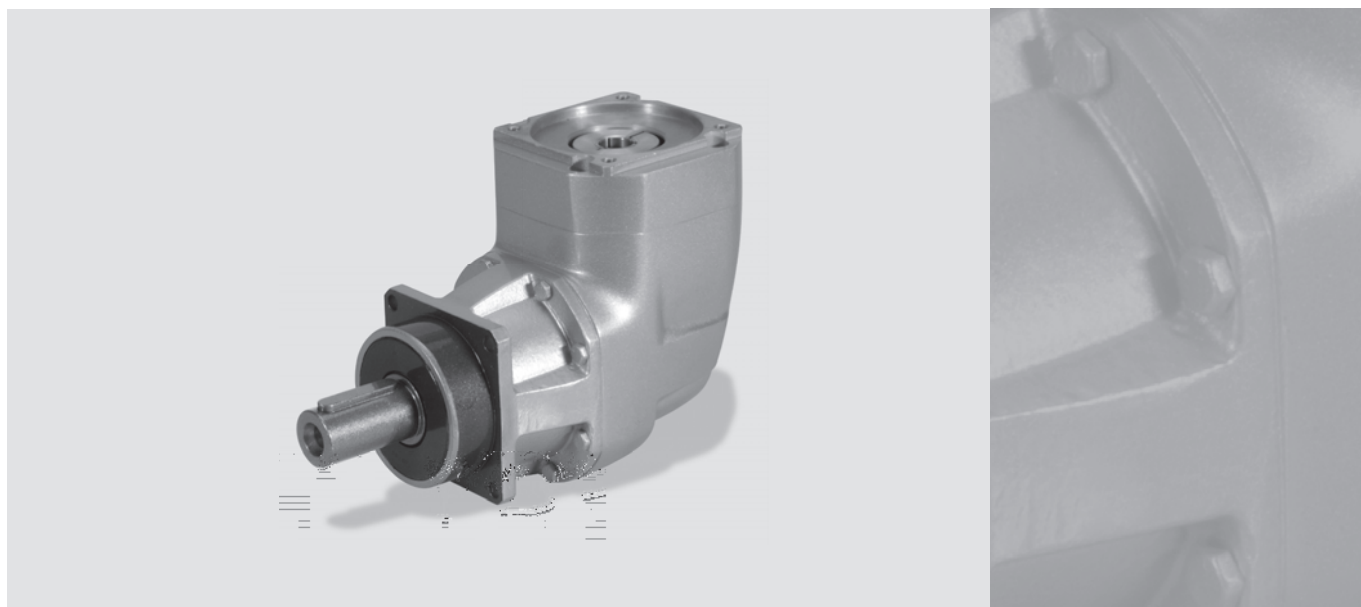

Produktmerkmale:

- Höchste Drehmomentdichte
- Höchstes Beschleunigungs- und Nenndrehmoment
- Höchste radiale und axiale Belastbarkeit
- Entwickelt für Zyklus- und Dauerbetrieb
- Höchste Verdrehsteifigkeit
- Niedriges Verdrehflankenspiel – unter 4 arcmin
- Laufruhig
- Einsetzbar in beliebiger Montageposition

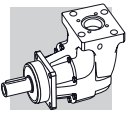

4 MERKMALE DER TQK-REIHE

Die spielarmen Kegelrad-Planetengetriebe der Baureihe TQK sind die Lösung bei Platzproblemen, die durch zunehmend kompaktere Maschinen immer häufiger auftreten.

TQK Getriebe vereinen ein extrem dynamisches Betriebsverhalten mit maximaler Präzision. Damit verleihen sie jeder Positioniermechanik, in die sie installiert werden, höchste Genauigkeit und Wiederholbarkeit.

Außer ihrer Robustheit und Verlässlichkeit haben TQK-Antriebe etwas unverkennbar Italienisches, das sie von ähnlichen Produkten in der Branche deutlich unterscheidet.

- Die TQK-Reihe hat zwei Präzisionsklassen, mit diesem Verdrehflankenspiel:
2-stufige Getriebe: standard $\varphi_S \leq 5'$; reduziert $\varphi_R \leq 4'$ ($\varphi_S \leq 6'$; $\varphi_R \leq 5'$ für TQK 060 und TQK 070)
3-stufige Getriebe: standard $\varphi_S \leq 7'$; reduziert $\varphi_R \leq 6'$ ($\varphi_S \leq 8'$; $\varphi_R \leq 7'$ für TQK 060 und TQK 070)
- Eine hohe IP-Schutzklasse (IP65) sorgt dafür, dass innenliegende Teile vor Staub- und Flüssigkeitseintritt geschützt sind.
- Serienmäßige Fluorelastomer-Wellendichtungen an der Eingangswelle
- Schalldruckpegel $60 \leq L_p \leq 70$ dB(A). Gemessen in 1 m Abstand ohne Last und bei einer Eingangsrehzahl von $n_1 = 3000 \text{ min}^{-1}$; $i = 20$.
- Große Auswahl an Motoradaptern sorgt für den Anschluss an die marktgängigsten Servomotoren.
- Schmierung optimiert für die gewünschte Betriebsart.
Ohne Verunreinigung muss das Schmiermittel nicht regelmäßig gewechselt werden.

Betrieb	TQK 060 ... TQK 160	andere Dichtungen
S1 (kontinuierlich)	Synthetiköl Viskositätsklasse ISO VG 220	Fluorelastomer
S5 (unterbrochen)	NLGI Fettkonsistenz 00	NBR

- Umgebungstemperatur min. -20°C , max. $+30^\circ\text{C}$; bei Temperaturen höher als 30°C ist der Temperaturfaktor f_T zu berücksichtigen.
- Die Gehäusetemperatur darf $T_{\text{max}} = 90^\circ\text{C}$ nicht übersteigen.

		Übersicht der Nenndrehmomente M_{n2} [Nm]														
	[i]	6	8	10	14	18	20	24	30	40	50	70	80	100	140	200
TQK 060		21	28	30	25	21	20	30	30	30	30	30	30	30	25	20
TQK 070		45	60	70	60	45	40	70	70	70	70	70	70	70	60	40
TQK 090		110	150	180	160	130	110	200	180	180	180	180	200	180	160	110
TQK 130		255	340	400	360	260	280	400	400	400	400	400	400	400	360	280
TQK 160		420	560	700	750	530	550	800	800	800	800	800	800	800	750	550

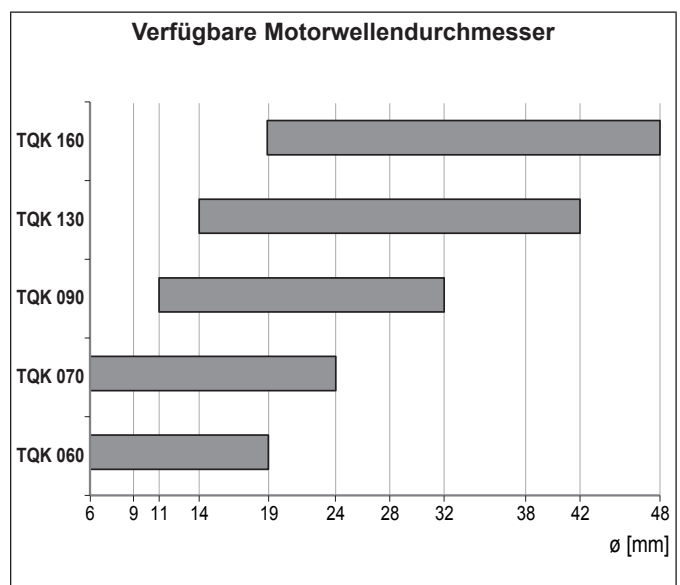
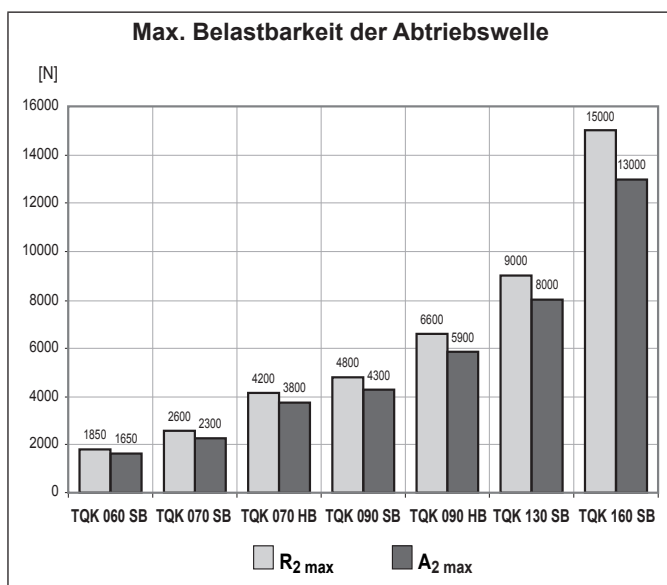

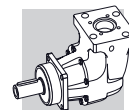

4.1 BESTELLBEZEICHNUNG

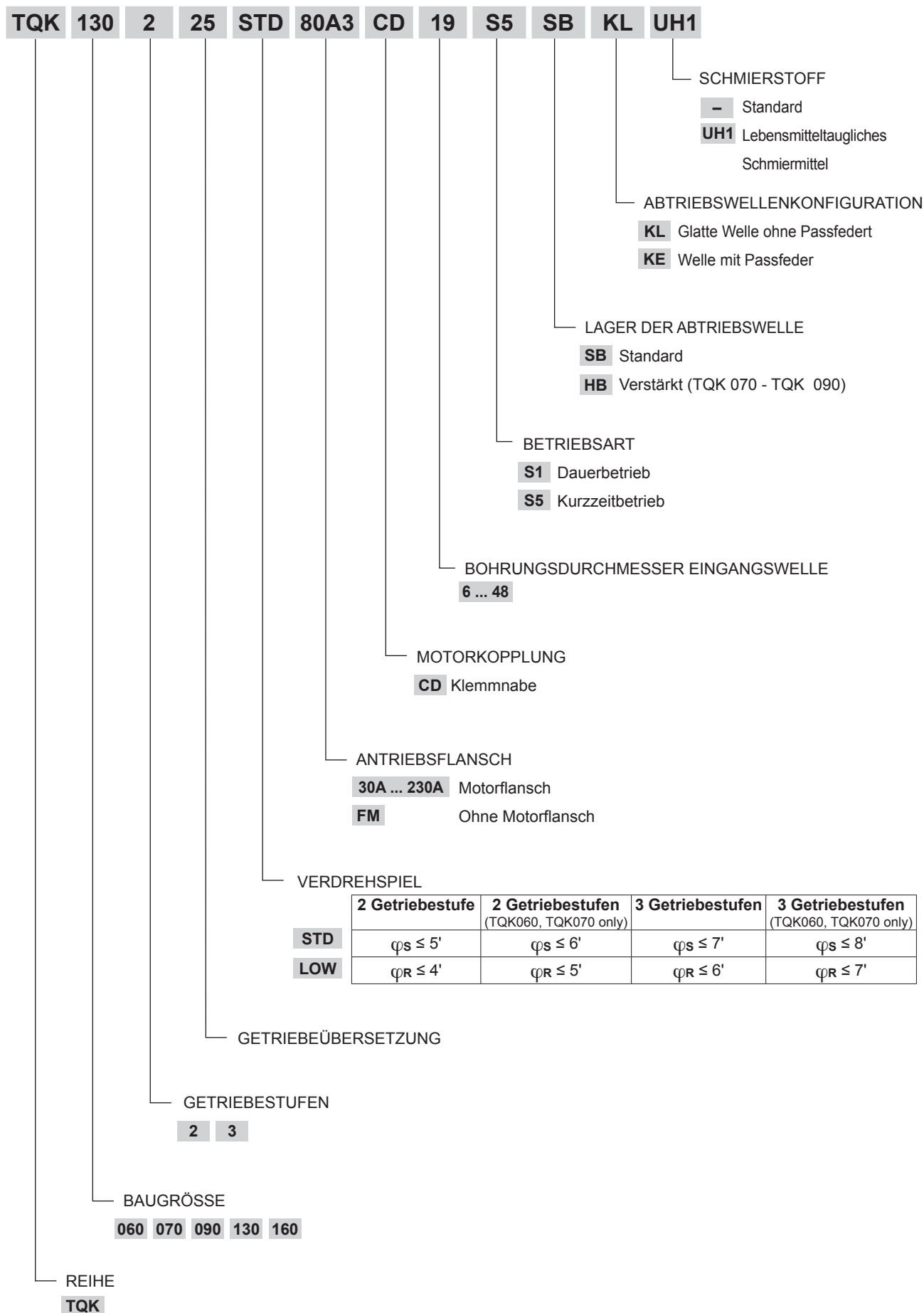

TQK

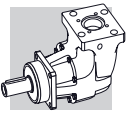

4.2 ABMESSUNGEN UND TECHNISCHE DATEN

TQK 060

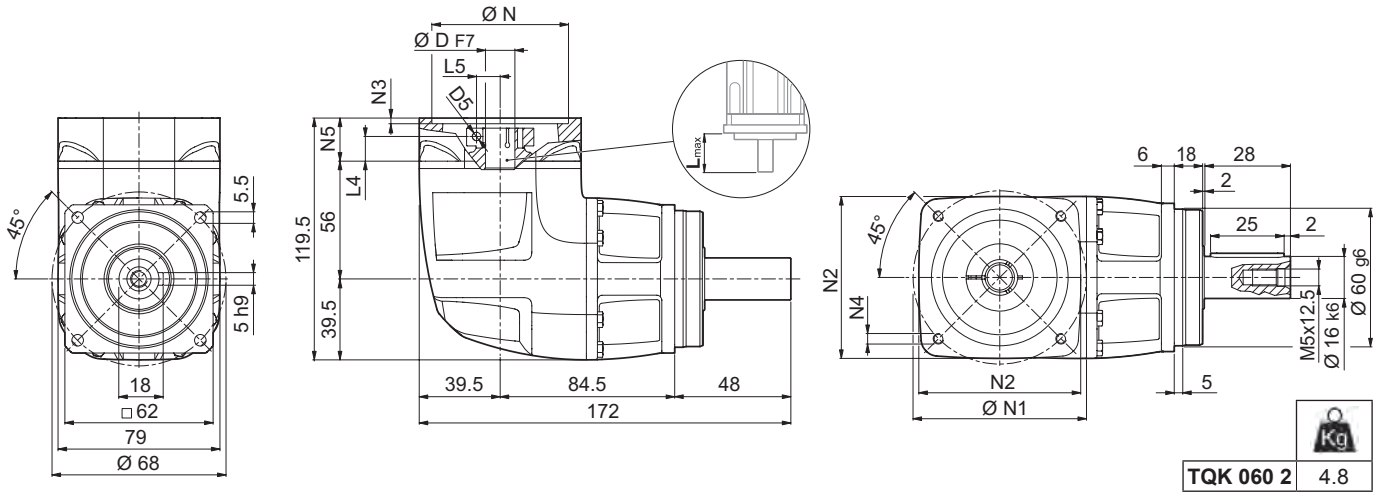

30A ... 110B0

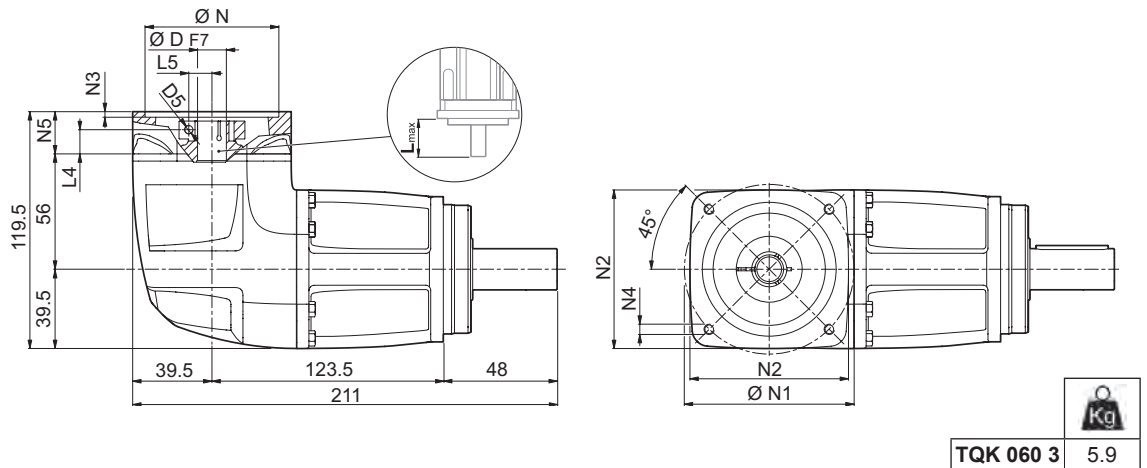

						N	N1	N2	N3	N4	N5	L _{max}
30A	6	-	-	-	-	30	46	60	3.5	M4x10	24	40
40B1	6	9	11	14	-	40	63	60	3.5	M4x10	24	40
50A1	6	9	11	14	-	50	60	60	4.0	M4x10	24	40
50C1	6	9	11	14	-	50	70	60	4.0	M4x10	24	40
60A2	6	9	11	14	19	60	75	80	4.0	M5x12	24	40
70B1	6	9	11	14	19	70	90	80	4.0	M5x12	24	40
80A1	6	9	11	14	19	80	100	100	4.0	M6x14	24	40
95A	6	9	11	14	19	95	115	100	4.0	M8x24*	24	40
110B0	6	9	11	14	19	110	145	120	4.0	M8x24*	24	40

* Durchgehend Für weitere Motoradapter und Antriebswellenbohrungen bitte nachfragen.

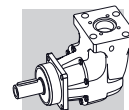

TQK 060

FM

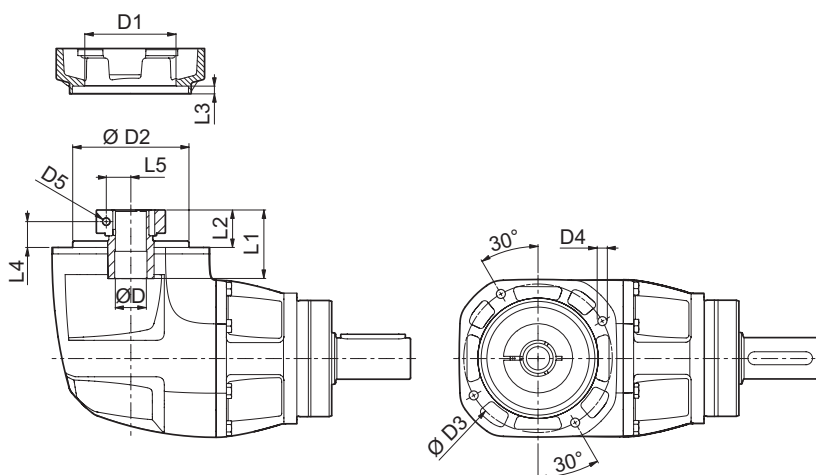

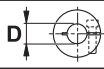
	D1	D2	D3	D4	D5	L1	L2	L3	L4	L5
6	37	59	72	M5x11	M4	31.5	15.5	4.5	10.5	8
9	49	59	72	M5x11	M5	35	19	4.5	11.5	10.5
11	49	59	72	M5x11	M6	35	19	4.5	11.5	12.5
14	49	59	72	M5x11	M6	35	19	4.5	11.5	14.5
19	54	59	72	M5x11	M6	35	19	4.5	11.5	16.5

TQK

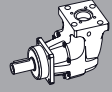
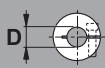
	i	M _{n2} [Nm]	M _{a2} [Nm]	M _{p2} [Nm]	n ₁ [min ⁻¹]	n _{1 max} [min ⁻¹]	φ _S ≤ [arcmin]	φ _R [arcmin]	C _t [$\frac{Nm}{arcmin}$]	R _{2 max} [N]	A _{2 max} [N]	η %	J _G [kgcm ²]		
														6 - 9	11 - 14
TQK 060 2_6		21	30	45	2500	5000	6'	5'	4.3	1850	1650	94	0.76	0.78	0.78
TQK 060 2_8		28	40	60	2500	5000	6'	5'	4.3	1850	1650	94	0.75	0.76	0.77
TQK 060 2_10		30	45	70	2500	5000	6'	5'	4.3	1850	1650	94	0.73	0.75	0.75
TQK 060 2_14		25	38	70	2500	5000	6'	5'	4.3	1850	1650	94	0.72	0.73	0.74
TQK 060 2_20		20	30	55	2500	5000	6'	5'	4.3	1850	1650	94	0.71	0.72	0.73
TQK 060 3_18		21	32	60	2500	5000	8'	7'	4.3	1850	1650	91	0.61	0.62	0.63
TQK 060 3_24		30	45	80	2500	5000	8'	7'	4.3	1850	1650	91	0.61	0.62	0.63
TQK 060 3_30		30	45	80	2500	5000	8'	7'	4.3	1850	1650	91	0.60	0.62	0.62
TQK 060 3_40		30	45	80	2500	5000	8'	7'	4.3	1850	1650	91	0.60	0.61	0.62
TQK 060 3_50		30	45	80	2500	5000	8'	7'	4.3	1850	1650	91	0.60	0.61	0.62
TQK 060 3_70		30	45	80	2500	5000	8'	7'	4.3	1850	1650	91	0.60	0.61	0.62
TQK 060 3_80		30	45	80	2500	5000	8'	7'	4.3	1850	1650	91	0.60	0.61	0.62
TQK 060 3_100		30	45	80	2500	5000	8'	7'	4.3	1850	1650	91	0.59	0.61	0.61
TQK 060 3_140		25	38	70	2500	5000	8'	7'	4.3	1850	1650	91	0.59	0.61	0.61
TQK 060 3_200		20	30	55	2500	5000	8'	7'	4.3	1850	1650	91	0.59	0.61	0.61

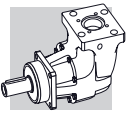

TQK 070

50C2 ... 130A

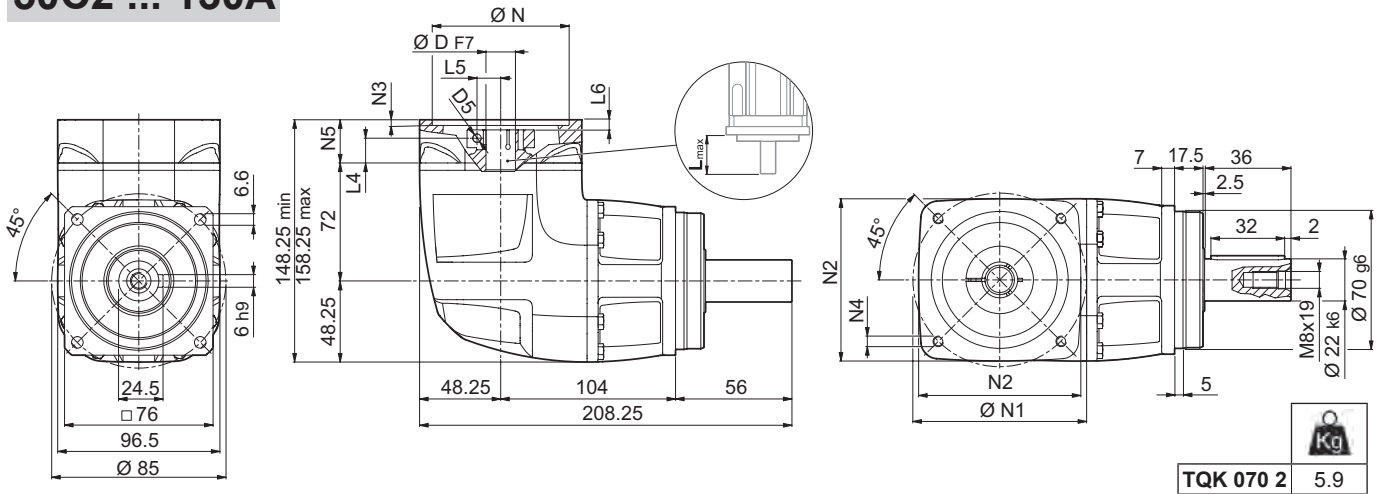

TQK 070 2 5.9

30A ... 110B0

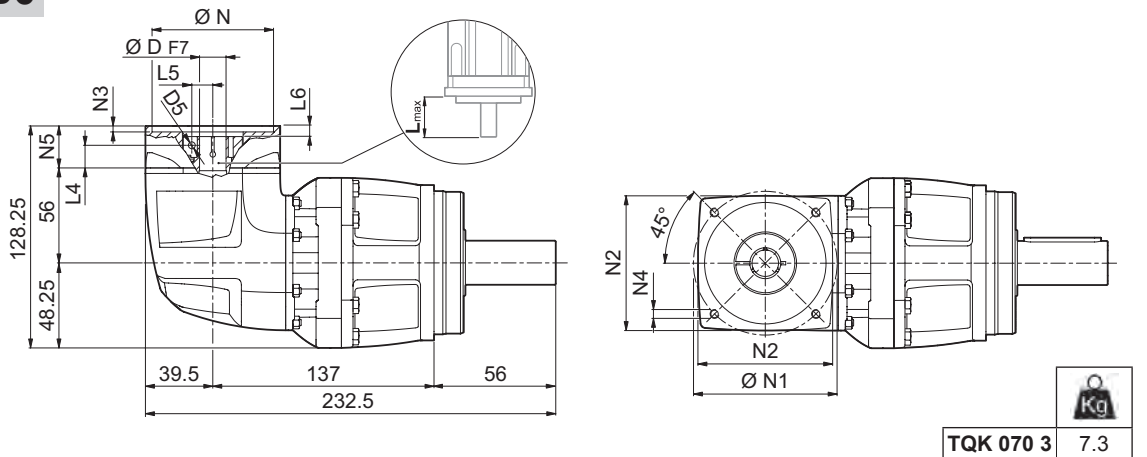

TQK 070 3 7.3

							N	N1	N2	N3	N4	N5	L _{max}
	D												
TQK 070 2													
50C2	6	9	11	14	-	-	50	70	80	6.5	M4x12	28	50
60A3	6	9	11	14	19	-	60	75	80	6.5	M5x14	28	50
70B2	6	9	11	14	19	-	70	90	80	6.5	M5x14	28	50
80A2	6	9	11	14	19	-	80	100	100	6.5	M6x14	28	50
95A1	6	9	11	14	19	24	95	115	100	6.5	M8x18	28	50
110A1	6	9	11	14	19	24	110	130	120	6.5	M8x18	28	50
110B1	6	9	11	14	19	24	110	145	120	6.5	M8x20	38	60
130A	6	9	11	14	19	24	130	165	140	6.5	M10x19	28	50
TQK 070 3													
30A	6	-	-	-	-	-	30	46	60	3.5	M4x10	24	40
40B1	6	9	11	14	-	-	40	63	60	3.5	M4x10	24	40
50A1	6	9	11	14	-	-	50	60	60	4.0	M4x10	24	40
50C1	6	9	11	14	-	-	50	70	60	4.0	M4x10	24	40
60A2	6	9	11	14	19	-	60	75	80	4.0	M5x12	24	40
70B1	6	9	11	14	19	-	70	90	80	4.0	M5x12	24	40
80A1	6	9	11	14	19	-	80	100	100	4.0	M6x14	24	40
95A	6	9	11	14	19	-	95	115	100	4.0	M8x24*	24	40
110B0	6	9	11	14	19	-	110	145	120	4.0	M8x24*	24	40

* Durchgehend Für weitere Motoradapter und Antriebswellenbohrungen bitte nachfragen.

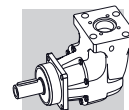

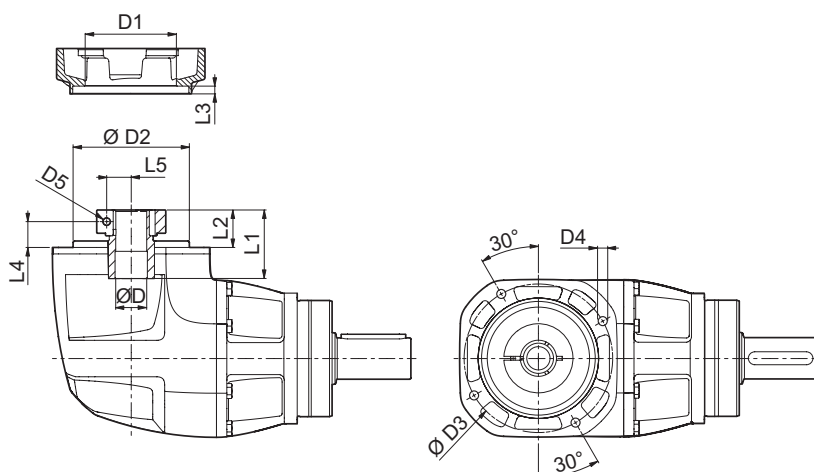

TQK 070

FM

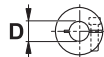

TQK

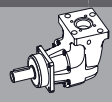
	D1	D2	D3	D4	D5	L1	L2	L3	L4	L5
TQK 070 2										
11	51	70	85	M6x11	M6	42	20	5	12.5	12.5
14	51	70	85	M6x11	M6	42	20	5	12.5	14.5
19	51	70	85	M6x11	M6	42	20	5	12.5	16.5
24	60	70	85	M6x11	M6	43.5	21.5	5	12.5	19
TQK 070 3										
6	37	59	72	M5x11	M4	31.5	15.5	4.5	10.5	8
9	49	59	72	M5x11	M5	35	19	4.5	11.5	10.5
11	49	59	72	M5x11	M6	35	19	4.5	11.5	12.5
14	49	59	72	M5x11	M6	35	19	4.5	11.5	14.5
19	54	59	72	M5x11	M6	35	19	4.5	11.5	16.5

	i	M _{n 2} [Nm]	M _{a 2} [Nm]	M _{p 2} [Nm]	n ₁ [min ⁻¹]	n _{1 max} [min ⁻¹]	φ _S [arcmin]	φ _R [arcmin]	C _t [Nm/arcmin]	SB		HB		η %	J _G [kgcm ²]			
										R _{2 max} [N]	A _{2 max} [N]	R _{2 max} [N]	A _{2 max} [N]					
															6 - 9	11 - 14	19	24
TQK 070 2_6		45	65	90	2500	5000	6'	5'	11	2600	2300	4200	3800	94	-	1.52	1.55	1.63
TQK 070 2_8		60	85	120	2500	5000	6'	5'	11	2600	2300	4200	3800	94	-	1.44	1.47	1.55
TQK 070 2_10		70	100	150	2500	5000	6'	5'	11	2600	2300	4200	3800	94	-	1.41	1.43	1.52
TQK 070 2_14		60	90	160	2500	5000	6'	5'	11	2600	2300	4200	3800	94	-	1.38	1.41	1.49
TQK 070 2_20		40	60	110	2500	5000	6'	5'	11	2600	2300	4200	3800	94	-	1.36	1.39	1.48
TQK 070 3_18		45	65	120	2500	5000	8'	7'	11	2600	2300	4200	3800	91	1.28	1.39	1.42	-
TQK 070 3_24		70	100	180	2500	5000	8'	7'	11	2600	2300	4200	3800	91	1.26	1.37	1.40	-
TQK 070 3_30		70	100	180	2500	5000	8'	7'	11	2600	2300	4200	3800	91	1.25	1.36	1.39	-
TQK 070 3_40		70	100	180	2500	5000	8'	7'	11	2600	2300	4200	3800	91	1.20	1.31	1.34	-
TQK 070 3_50		70	100	180	2500	5000	8'	7'	11	2600	2300	4200	3800	91	1.19	1.31	1.33	-
TQK 070 3_70		70	100	180	2500	5000	8'	7'	11	2600	2300	4200	3800	91	1.18	1.29	1.32	-
TQK 070 3_80		70	100	180	2500	5000	8'	7'	11	2600	2300	4200	3800	91	1.17	1.29	1.31	-
TQK 070 3_100		70	100	180	2500	5000	8'	7'	11	2600	2300	4200	3800	91	1.17	1.28	1.31	-
TQK 070 3_140		60	90	160	2500	5000	8'	7'	11	2600	2300	4200	3800	91	1.16	1.27	1.30	-
TQK 070 3_200		40	60	110	2500	5000	8'	7'	11	2600	2300	4200	3800	91	1.15	1.27	1.29	-

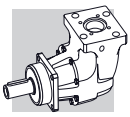

TQK 090

60A4 ... 180A1

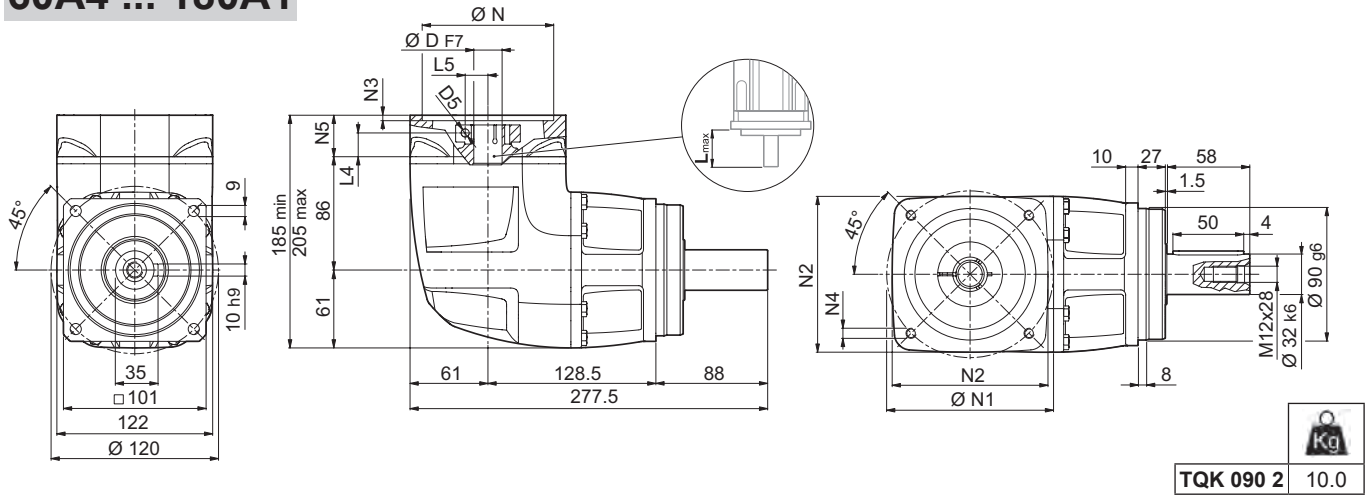

50C2 ... 130A

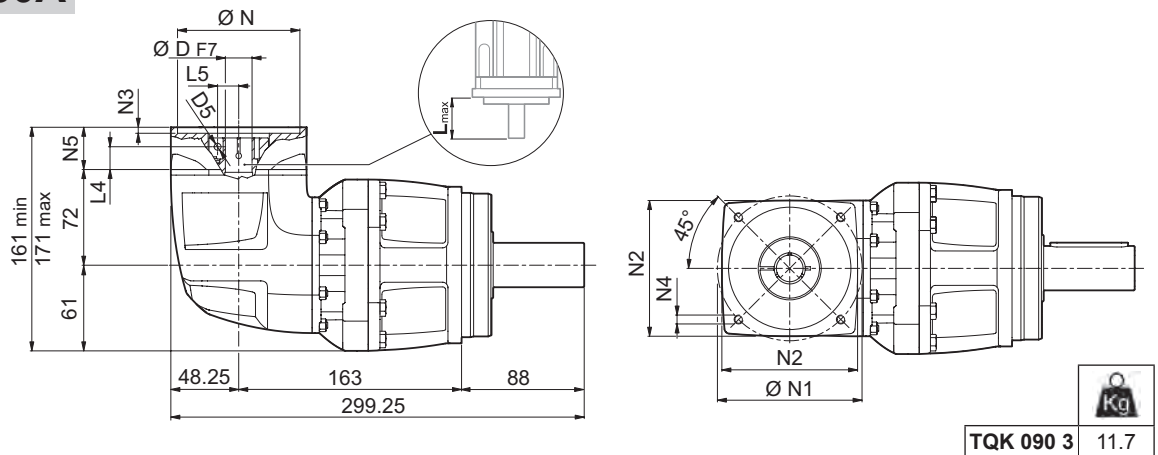

	D						N	N1	N2	N3	N4	N5	L _{max}
TQK 090 2													
60A4	11	14	19	-	-	-	60	75	100	6.5	M5x14	38	60
80A3	11	14	19	-	-	-	80	100	100	6.5	M6x14	38	60
95A2	11	14	19	24	28	-	95	115	100	6.5	M8x18	38	60
110A2	11	14	19	24	-	-	110	130	122	6.5	M8x20	38	60
110B1	11	14	19	24	28	-	110	145	122	6.5	M8x20	38	60
130A1	11	14	19	24	28	32	130	165	140	6.5	M10x20	38	60
180A	11	14	19	24	28	32	180	215	190	6.5	M14x38*	38	60
180A1	11	14	19	24	28	32	180	215	190	6.5	M14x28	58	80
TQK 090 3													
50C2	11	14	-	-	-	-	50	70	80	6.5	M4x12	28	50
60A3	11	14	19	-	-	-	60	75	80	6.5	M5x14	28	50
70B2	11	14	19	-	-	-	70	90	80	6.5	M5x14	28	50
80A2	11	14	19	-	-	-	80	100	100	6.5	M6x14	28	50
95A1	11	14	19	24	-	-	95	115	100	6.5	M8x18	28	50
110A1	11	14	19	24	-	-	110	130	120	6.5	M8x18	28	50
110B1	11	14	19	24	-	-	110	145	120	6.5	M8x20	38	60
130A	11	14	19	24	-	-	130	165	140	6.5	M10x19	28	50

* Durchgehend Für weitere Motoradapter und Antriebswellenbohrungen bitte nachfragen.

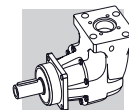

TQK 090

FM

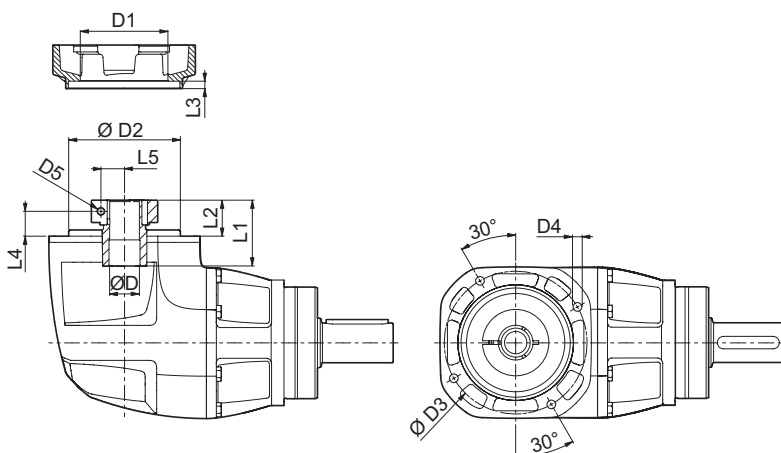

TQK

	D1	D2	D3	D4	D5	L1	L2	L3	L4	L5
TQK 090 2										
14	51	90	115	M8x13	M6	50	28	6.5	20.5	14.5
19	51	90	115	M8x13	M6	50	28	6.5	20.5	16.5
24	60	90	115	M8x13	M6	51.5	29.5	6.5	20.5	19
28	72	90	115	M8x13	M8	51.5	29.5	6.5	20.5	22.5
32	72	90	115	M8x13	M8	51.5	29.5	6.5	20.5	24.5
38	80	90	115	M8x13	M8	51.5	29.5	6.5	20.5	28
TQK 090 3										
11	51	70	85	M6x11	M6	42	20	5	12.5	12.5
14	51	70	85	M6x11	M6	42	20	5	12.5	14.5
19	51	70	85	M6x11	M6	42	20	5	12.5	16.5
24	60	70	85	M6x11	M6	43.5	21.5	5	12.5	19

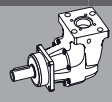
	i	M _{n 2} [Nm]	M _{a 2} [Nm]	M _{p 2} [Nm]	n ₁ [min ⁻¹]	n _{1 max} [min ⁻¹]	φ _S [arcmin]	φ _R [arcmin]	C _t [Nm/arcmin]	SB		HB		η %	J _G [kgcm ²]			
										R _{2 max} [N]	A _{2 max} [N]	R _{2 max} [N]	A _{2 max} [N]		11	14	19 - 24	28 - 32
TQK 090 2_6		110	150	225	2000	4500	5'	4'	28	4800	4300	6600	5900	94	-	4.82	4.89	5.42
TQK 090 2_8		150	208	300	2000	4500	5'	4'	28	4800	4300	6600	5900	94	-	4.56	4.63	5.16
TQK 090 2_10		180	260	360	2000	4500	5'	4'	28	4800	4300	6600	5900	94	-	4.45	4.51	5.04
TQK 090 2_14		160	250	500	2000	4500	5'	4'	28	4800	4300	6600	5900	94	-	4.34	4.41	4.94
TQK 090 2_20		110	170	350	2000	4500	5'	4'	28	4800	4300	6600	5900	94	-	4.29	4.36	4.88
TQK 090 3_18		130	200	400	2000	4500	7'	6'	28	4800	4300	6600	5900	91	3.56	3.63	3.70	-
TQK 090 3_24		200	300	500	2000	4500	7'	6'	28	4800	4300	6600	5900	91	3.53	3.60	3.67	-
TQK 090 3_30		180	280	500	2000	4500	7'	6'	28	4800	4300	6600	5900	91	3.52	3.59	3.66	-
TQK 090 3_40		180	280	500	2000	4500	7'	6'	28	4800	4300	6600	5900	91	3.45	3.52	3.58	-
TQK 090 3_50		180	280	500	2000	4500	7'	6'	28	4800	4300	6600	5900	91	3.42	3.49	3.56	-
TQK 090 3_70		180	280	500	2000	4500	7'	6'	28	4800	4300	6600	5900	91	3.40	3.46	3.53	-
TQK 090 3_80		200	300	500	2000	4500	7'	6'	28	4800	4300	6600	5900	91	3.38	3.45	3.52	-
TQK 090 3_100		180	280	500	2000	4500	7'	6'	28	4800	4300	6600	5900	91	3.38	3.45	3.52	-
TQK 090 3_140		160	250	500	2000	4500	7'	6'	28	4800	4300	6600	5900	91	3.38	3.45	3.52	-
TQK 090 3_200		110	170	350	2000	4500	7'	6'	28	4800	4300	6600	5900	91	3.38	3.45	3.52	-

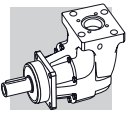

TQK 130

80A3 ... 200A

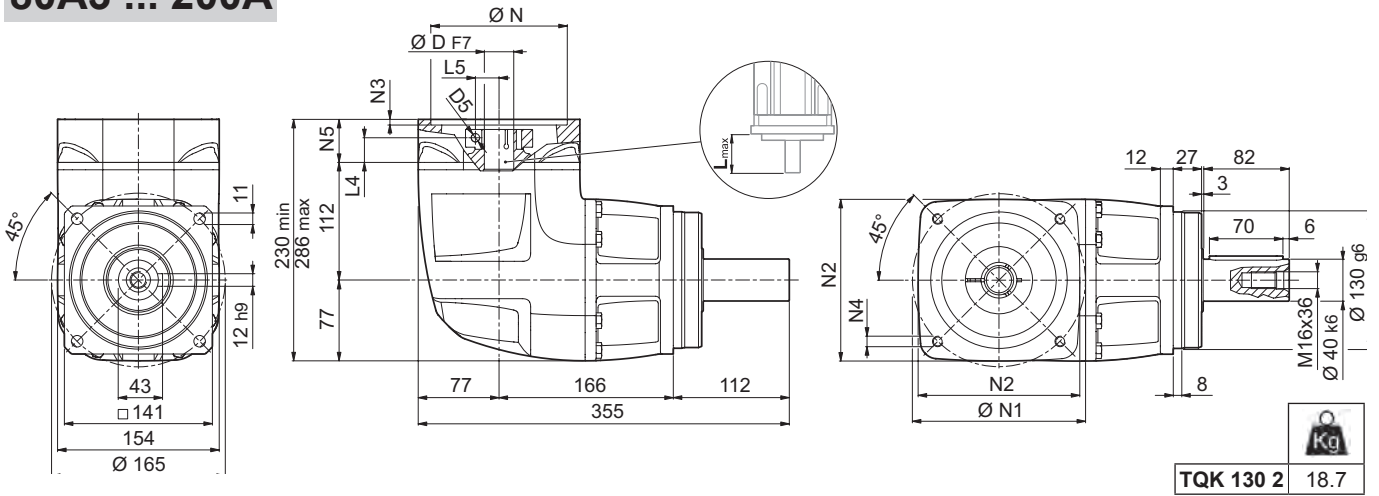

TQK 130 2 18.7

60A4 ... 180A1

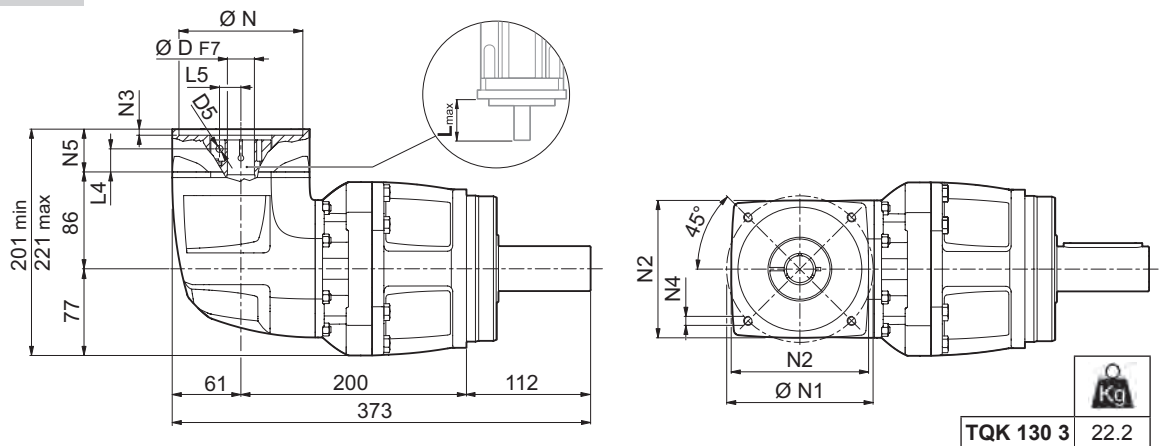

TQK 130 3 22.2

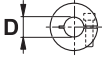
								N	N1	N2	N3	N4	N5	L _{max}
TQK 130 2														
80A3	14	19	-	-	-	-	-	80	100	130	6.5	M6x14	41	60
95A2	14	19	24	28	-	-	-	95	115	130	6.5	M8x18	41	60
110A2	14	19	24	-	-	-	-	110	130	130	6.5	M8x20	41	60
110B1	14	19	24	28	-	-	-	110	145	130	6.5	M8x20	41	60
130A1	14	19	24	28	32	-	-	130	165	154	6.5	M10x20	41	60
180A	14	19	24	28	32	-	-	180	215	190	6.5	M14x28	41	60
180A1	14	19	24	28	32	38	-	180	215	190	6.5	M14x28	61	80
200A	14	19	24	28	32	38	42	200	235	210	6.5	M14x28	97	110
TQK 130 3														
60A4	14	19	-	-	-	-	-	60	75	100	6.5	M5x14	38	60
80A3	14	19	-	-	-	-	-	80	100	100	6.5	M6x14	38	60
95A2	14	19	24	28	-	-	-	95	115	100	6.5	M8x18	38	60
110A2	14	19	24	-	-	-	-	110	130	122	6.5	M8x20	38	60
110B1	14	19	24	28	-	-	-	110	145	122	6.5	M8x20	38	60
130A1	14	19	24	28	32	-	-	130	165	140	6.5	M10x20	38	60
180A	14	19	24	28	32	-	-	180	215	190	6.5	M14x38	38	60
180A1	14	19	24	28	32	38	-	180	215	190	6.5	M14x28	58	80

* Durchgehend Für weitere Motoradapter und Antriebswellenbohrungen bitte nachfragen.

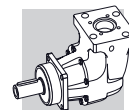

TQK 130

FM

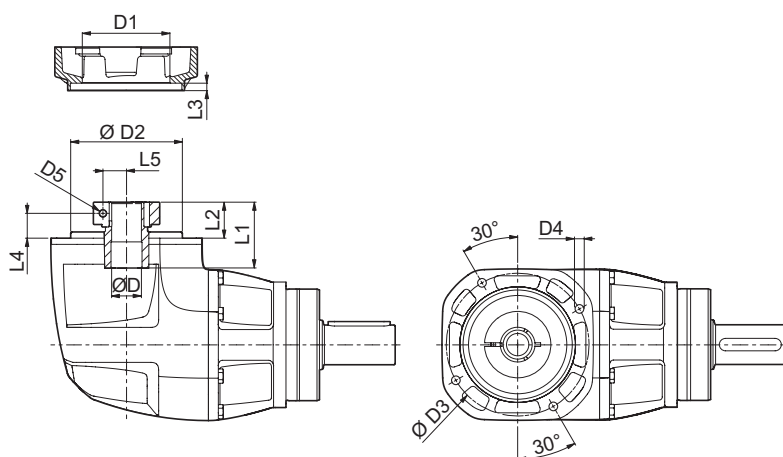

TQK

	D1	D2	D3	D4	D5	L1	L2	L3	L4	L5
TQK 130 2										
19	54	120	140	M10x16	M6	50	31	7.5	23.5	16.5
24	70	120	140	M10x16	M6	51.5	32.5	7.5	23.5	19
28	70	120	140	M10x16	M8	51.5	32.5	7.5	23.5	22.5
32	72	120	140	M10x16	M8	51.5	32.5	7.5	23.5	24.5
38	100	120	140	M10x16	M8	54	35	7.5	23.5	28
42	114	120	140	M10x16	M10	51.5	38.5	7.5	23.5	33
TQK 130 3										
14	51	90	115	M8x13	M6	50	28	6.5	20.5	14.5
19	51	90	115	M8x13	M6	50	28	6.5	20.5	16.5
24	60	90	115	M8x13	M6	51.5	29.5	6.5	20.5	19
28	72	90	115	M8x13	M8	51.5	29.5	6.5	20.5	22.5
32	72	90	115	M8x13	M8	51.5	29.5	6.5	20.5	24.5
38	80	90	115	M8x13	M8	51.5	29.5	6.5	20.5	28

	i	M _{n 2} [Nm]	M _{a 2} [Nm]	M _{p 2} [Nm]	n ₁ [min ⁻¹]	n _{1 max} [min ⁻¹]	φ _S ≤ [arcmin]	φ _R [arcmin]	C _t [Nm arcmin]	R _{2 max} [N]	A _{2 max} [N]	η %	J _G [kgcm ²]				
													14	19 - 24	28 - 32	38	42
TQK 130 2_6		255	360	510	2000	4500	5'	4'	56	9000	8000	94	-	17.44	18.02	18.55	24.47
TQK 130 2_8		340	480	680	2000	4500	5'	4'	56	9000	8000	94	-	16.31	16.89	17.41	23.33
TQK 130 2_10		400	600	850	2000	4500	5'	4'	56	9000	8000	94	-	15.77	16.35	16.88	22.80
TQK 130 2_14		360	550	950	2000	4500	5'	4'	56	9000	8000	94	-	15.35	15.93	16.46	22.38
TQK 130 2_20		280	420	900	2000	4500	5'	4'	56	9000	8000	94	-	15.13	15.71	16.23	22.15
TQK 130 3_18		260	400	900	2000	4500	7'	6'	56	9000	8000	91	15.18	15.34	15.92	16.44	-
TQK 130 3_24		400	600	1000	2000	4500	7'	6'	56	9000	8000	91	15.05	15.21	15.79	16.32	-
TQK 130 3_30		400	600	1000	2000	4500	7'	6'	56	9000	8000	91	14.99	15.15	15.73	16.26	-
TQK 130 3_40		400	600	1000	2000	4500	7'	6'	56	9000	8000	91	14.72	14.88	15.46	15.99	-
TQK 130 3_50		400	600	1000	2000	4500	7'	6'	56	9000	8000	91	14.61	14.77	15.35	15.88	-
TQK 130 3_70		400	600	1000	2000	4500	7'	6'	56	9000	8000	91	14.52	14.68	15.25	15.78	-
TQK 130 3_80		400	600	1000	2000	4500	7'	6'	56	9000	8000	91	14.47	14.63	15.21	15.74	-
TQK 130 3_100		400	600	1000	2000	4500	7'	6'	56	9000	8000	91	14.46	14.62	15.20	15.73	-
TQK 130 3_140		360	550	950	2000	4500	7'	6'	56	9000	8000	91	14.46	14.62	15.20	15.73	-
TQK 130 3_200		280	420	900	2000	4500	7'	6'	56	9000	8000	91	14.46	14.62	15.20	15.73	-

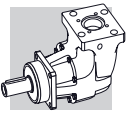

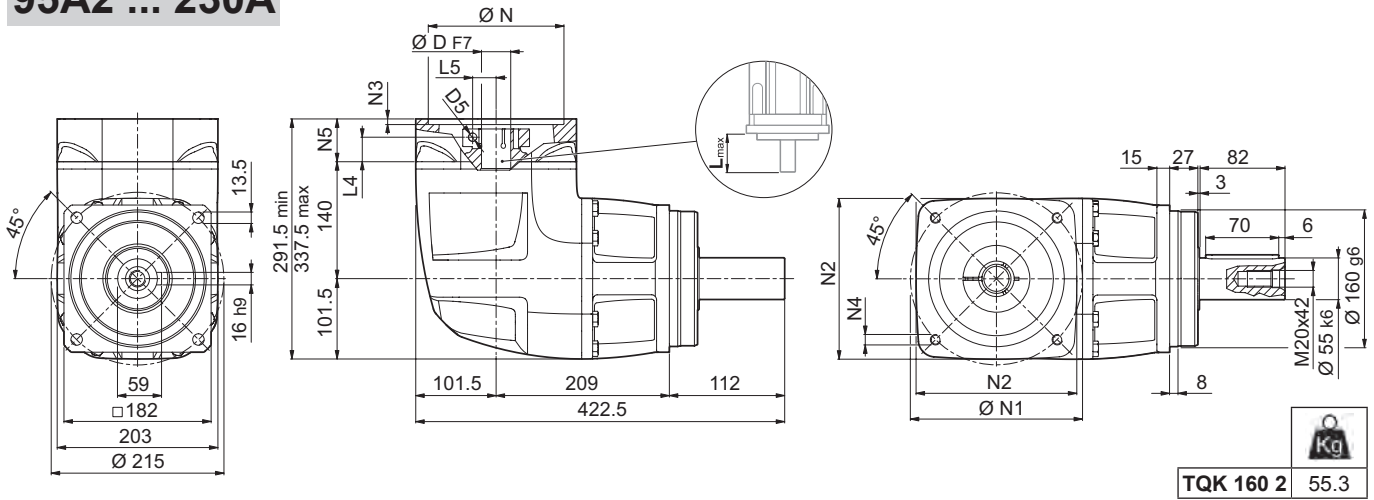

TQK 160

95A2 ... 230A

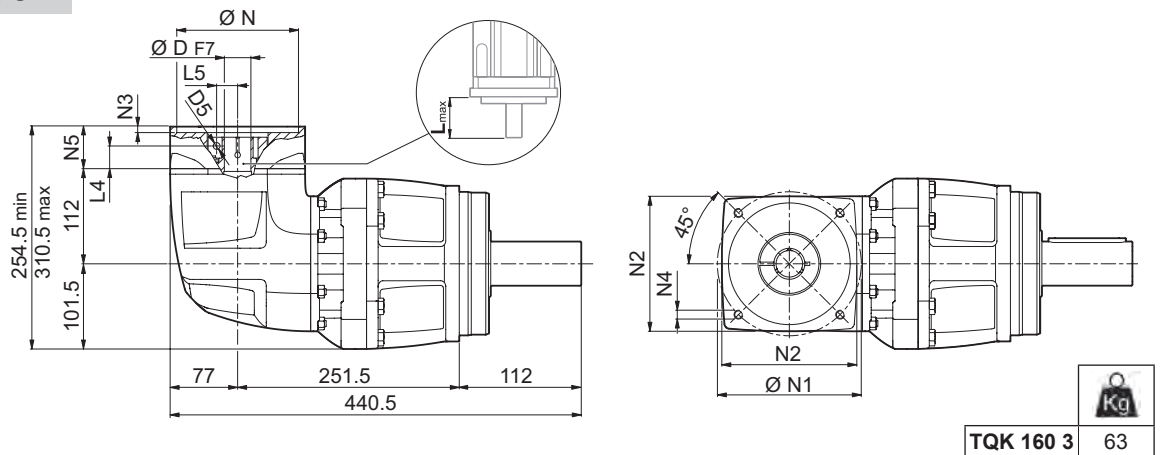

80A3 ... 200A

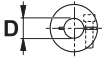

									N	N1	N2	N3	N4	N5	L _{max}
TQK 160 2															
95A2	19	24	28	-	-	-	-	95	115	158	6.5	M8x20	50	60	
110A2	19	24	-	-	-	-	-	110	130	158	6.5	M8x20	50	60	
130A1	19	24	28	32	-	-	-	130	165	158	6.5	M10x20	50	60	
180A	19	24	28	32	-	-	-	180	215	203	6.5	M14x28	50	60	
180A1	19	24	28	32	38	-	-	180	215	205	6.5	M14x28	60	80	
200A	19	24	28	32	38	42	48	200	235	220	6.5	M14x28	96	110	
230A	19	24	28	32	38	42	48	230	265	240	6.5	M14x28	96	110	
TQK 160 3															
80A3	19	-	-	-	-	-	-	80	100	130	6.5	M6x14	41	60	
95A2	19	24	28	-	-	-	-	95	115	130	6.5	M8x18	41	60	
110A2	19	24	-	-	-	-	-	110	130	130	6.5	M8x20	41	60	
110B1	19	24	28	-	-	-	-	110	145	130	6.5	M8x20	41	60	
130A1	19	24	28	32	-	-	-	130	165	154	6.5	M10x20	41	60	
180A	19	24	28	32	-	-	-	180	215	190	6.5	M14x28	41	60	
180A1	19	24	28	32	38	-	-	180	215	190	6.5	M14x28	61	80	
200A	19	24	28	32	38	42	-	200	235	210	6.5	M14x28	97	110	

Für weitere Motoradapter und Antriebswellenbohrungen bitte nachfragen.

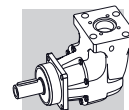

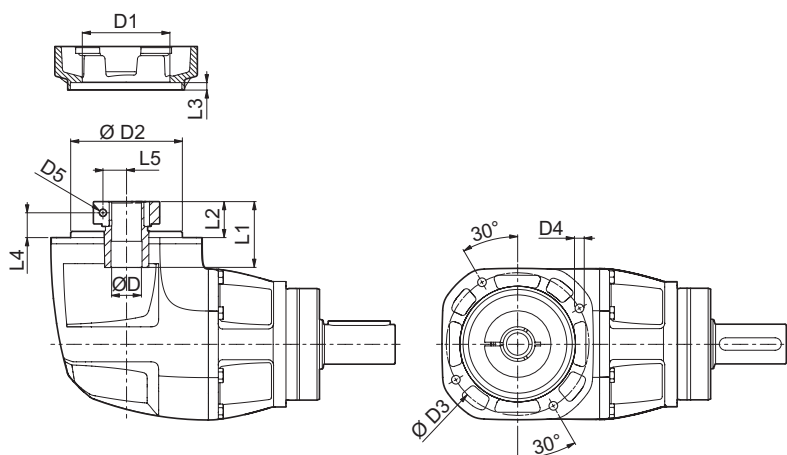

TQK 160

FM

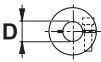

TQK

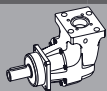
	D1	D2	D3	D4	D5	L1	L2	L3	L4	L5
TQK 160 2										
24	58	150	175	M12x20	M6	47	37	9.5	28	19
28	70	150	175	M12x20	M8	47	37	9.5	28	22.5
32	72	150	175	M12x20	M8	47	37	9.5	28	24.5
38	100	150	175	M12x20	M8	59.5	39.5	9.5	28	28
42	114	150	175	M12x20	M10	57	43	9.5	28	33
48	125	150	175	M12x20	M12	57	43	9.5	28	36.5
TQK 160 3										
19	54	120	140	M10x16	M6	50	31	7.5	23.5	16.5
24	70	120	140	M10x16	M6	51.5	32.5	7.5	23.5	19
28	70	120	140	M10x16	M8	51.5	32.5	7.5	23.5	22.5
32	72	120	140	M10x16	M8	51.5	32.5	7.5	23.5	24.5
38	100	120	140	M10x16	M8	54	35	7.5	23.5	28
42	114	120	140	M10x16	M10	51.5	38.5	7.5	23.5	33

	i	M _{n 2} [Nm]	M _{a 2} [Nm]	M _{p 2} [Nm]	n ₁ [min ⁻¹]	n _{1 max} [min ⁻¹]	φ _S [arcmin]	φ _R [arcmin]	C _t [Nm/arcmin]	R _{2 max} [N]	A _{2 max} [N]	η %	J _G [kgcm ²]				
														19	24 - 28	32 - 38	42
TQK 160 2_6		420	630	840	1600	4000	5'	4'	167	15000	13000	94	-	73.33	73.51	75.57	79.19
TQK 160 2_8		560	840	1120	1600	4000	5'	4'	167	15000	13000	94	-	69.49	69.66	71.73	75.34
TQK 160 2_10		700	1050	1400	1600	4000	5'	4'	167	15000	13000	94	-	67.98	68.16	70.22	73.83
TQK 160 2_14		750	1150	2000	1600	4000	5'	4'	167	15000	13000	94	-	66.68	66.85	68.92	72.53
TQK 160 2_20		550	850	1600	1600	4000	5'	4'	167	15000	13000	94	-	65.94	66.12	68.18	71.80
TQK 160 3_18		530	800	1500	1600	4000	7'	6'	167	15000	13000	91	66.84	67.17	67.34	69.41	-
TQK 160 3_24		800	1200	2000	1600	4000	7'	6'	167	15000	13000	91	66.47	66.79	66.97	69.03	-
TQK 160 3_30		800	1200	2000	1600	4000	7'	6'	167	15000	13000	91	66.30	66.63	66.80	68.87	-
TQK 160 3_40		800	1200	2000	1600	4000	7'	6'	167	15000	13000	91	65.41	65.73	65.91	67.97	-
TQK 160 3_50		800	1200	2000	1600	4000	7'	6'	167	15000	13000	91	64.99	65.32	65.49	67.56	-
TQK 160 3_70		800	1200	2000	1600	4000	7'	6'	167	15000	13000	91	64.67	65.00	65.17	67.24	-
TQK 160 3_80		800	1200	2000	1600	4000	7'	6'	167	15000	13000	91	64.51	64.84	65.01	67.08	-
TQK 160 3_100		800	1200	2000	1600	4000	7'	6'	167	15000	13000	91	64.49	64.82	65.00	67.06	-
TQK 160 3_140		750	1150	2000	1600	4000	7'	6'	167	15000	13000	91	64.48	64.81	64.99	67.05	-
TQK 160 3_200		550	850	1600	1600	4000	7'	6'	167	15000	13000	91	64.47	64.80	64.98	67.04	-

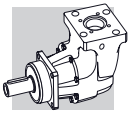

TQK



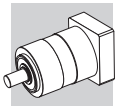

TR PRÄZISIONSPLANETENGETRIEBE

TR-Präzisionsplanetengetriebe zeichnen sich durch ein extrem reduziertes Axialspiel, optimale Leistung, Laufruhe, einfache Motormontage und höchste Zuverlässigkeit aus.

Sie sind in verschiedenen Konfigurationen (Antrieb rechtwinklig, Abtrieb rechtwinklig, Hohlwelle, Eingangsvollwelle) und Motoradaptern erhältlich und so mit den mechanischen Schnittstellen der marktgängigsten Servomotoren kompatibel.

TR

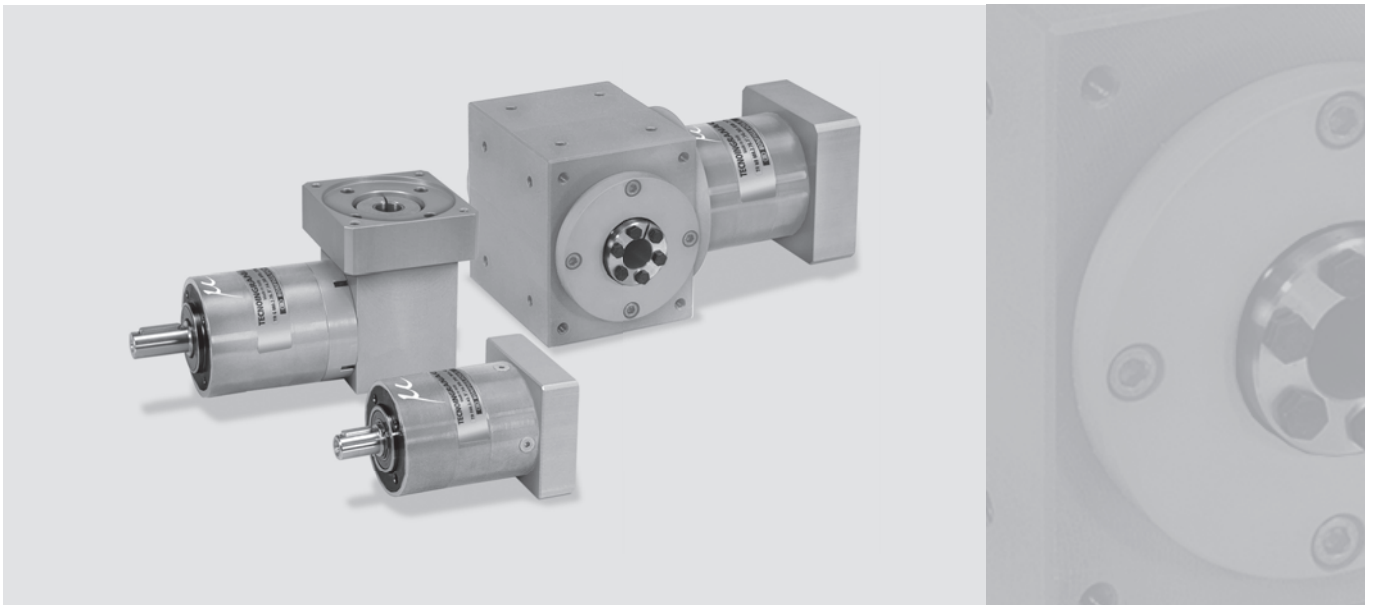

Produktmerkmale:

- Hohe Drehmomentdichte
- Hohes Beschleunigungs- und Nenndrehmoment
- Hohe radiale und axiale Belastbarkeit
- Entwickelt für Zyklus- und Dauerbetrieb
- Hohe Verdrehsteifigkeit
- Höchste Präzision dank des Verdrehflankenspiels von weniger als 3 arcmin
- Laufruhig
- Maximale Flexibilität (standard/reduziertes Flankenspiel; standard/verstärkte Lager)
- Verschiedene Varianten) für Ihre Anforderungen.



5 MERKMALE DER TR-REIHE

Die Planetengetriebe der TR-Reihe zeichnen sich durch geringes Verdrehspiel, hohes übertragbares Drehmoment und hohe Getriebeübersetzungen aus.

Alle Getriebe sind laufruhig und gewährleisten eine lange und wartungsarme Nutzungsdauer. Die Motormontage ist einfach und erfordert keinerlei Spezialwerkzeug.

- Erhältlich mit standard (STD) oder reduziertem (LOW) Verdrehflankenspiel:
 - 1-Stufige Getriebe: standard $\varphi_s \leq 5'$; reduziert $\varphi_R \leq 3'$
 - 2-Stufige Getriebe: standard $\varphi_s \leq 5'$; reduziert $\varphi_R \leq 3'$
 - 3-Stufige Getriebe (nur G und MB): standard $\varphi_R \leq 5'$; reduziert $\varphi_R \leq 3'$
 - 3-Stufige Getriebe: standard $\varphi_s \leq 7'$; reduziert $\varphi_R \leq 5'$
 - 4-Stufige Getriebe (nur G und MB): standard $\varphi_s \leq 7'$; reduziert $\varphi_R \leq 5'$
- Eine hohe IP-Schutzklasse (IP65) sorgt dafür, dass innenliegende Teile vor Staub- und Flüssigkeitseintritt geschützt sind.
- Serienmäßige Fluorelastomer-Wellendichtungen an der Eingangswelle
- Schalldruckpegel $L_p \leq 70$ dB(A). Gemessen in 1 m Abstand ohne Last und bei einer Eingangsdrehzahl von $n_1 = 3000$ min⁻¹; $i = 10$.
- Lager für eine durchschnittliche Lebensdauer von von 20.000 Stunden unter normalen Betriebsbedingungen geeignet. Die folgende Tabelle zeigt die Lagertypen für die Abtriebswelle.

	TR 053	TR 060	TR 080	TR 105	TR 130	TR 160	TR 190
SB							

TR

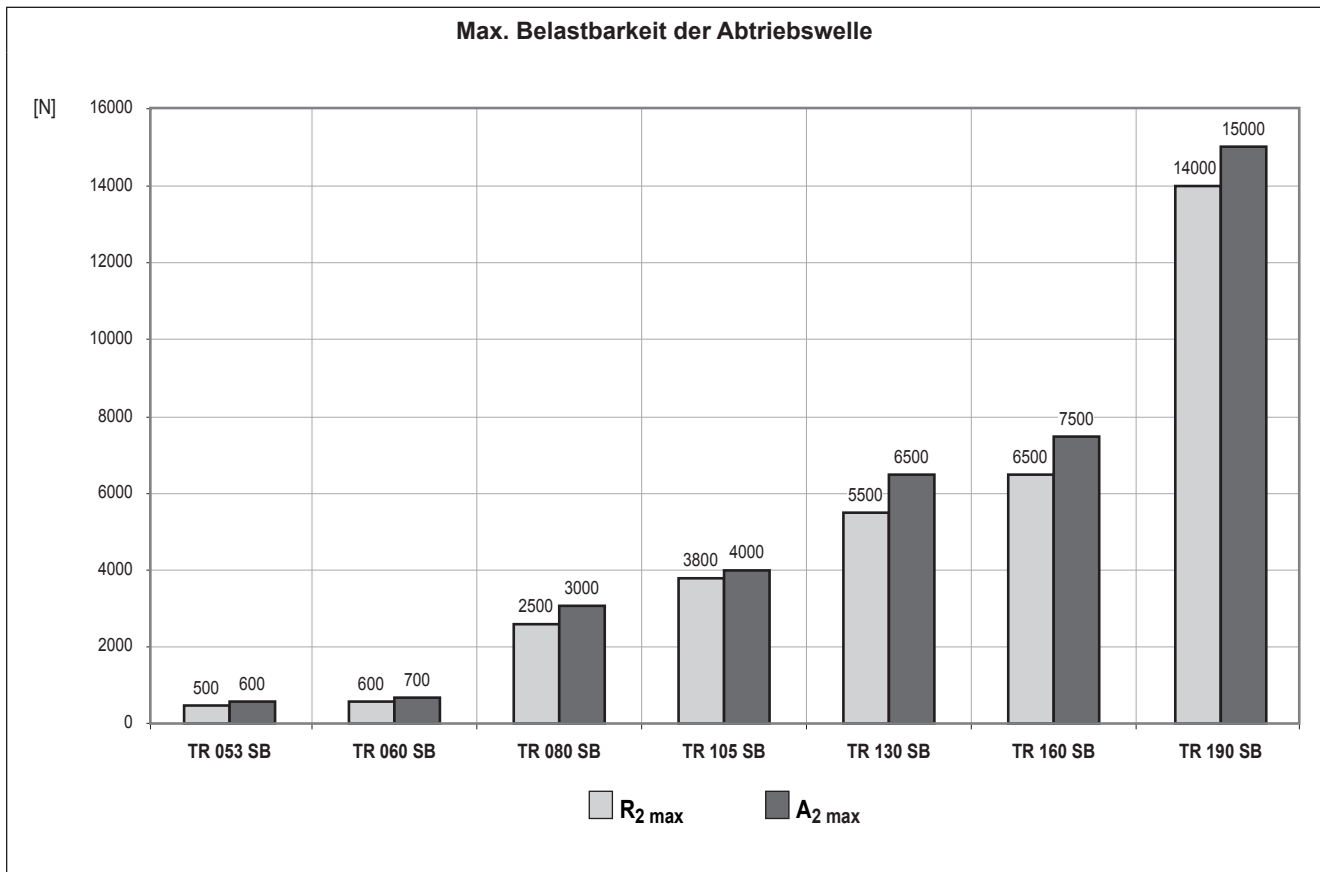

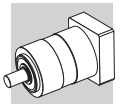

- Große Auswahl an Motoradaptern sorgt für den Anschluss an die marktgängigsten Servomotoren.

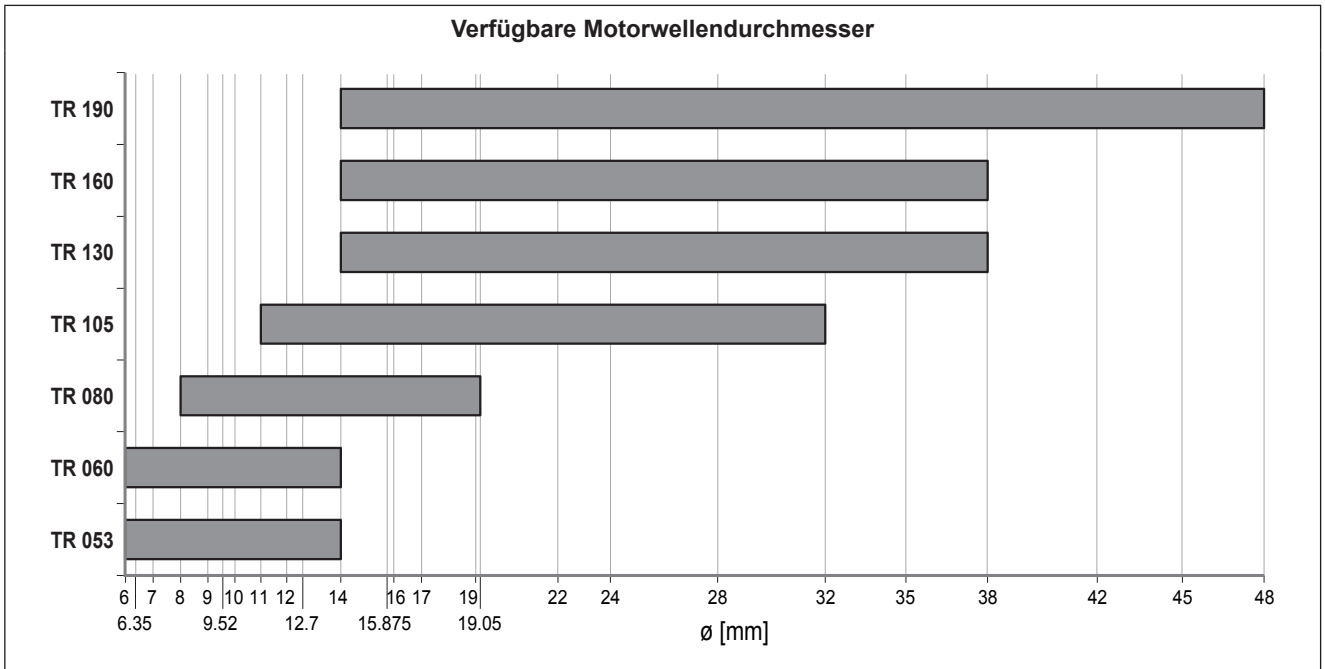

- Schmierung optimiert für die gewünschte Betriebsart.
Ohne Verunreinigung muss das Schmiermittel nicht regelmäßig gewechselt werden.

Betrieb	TR 053 - TR 060	TR 080 ... TR 190	andere Dichtungen
S1 (kontinuierlich)	NLGI Fettkonsistenz 00	Synthetiköl Viskositätsklasse ISO VG 220	Fluoroelastomer
S5 (unterbrochen)		NLGI Fettkonsistenz 00	NBR

- Umgebungstemperatur min. -20°C, max. +30°C; bei Temperaturen höher als 30°C ist der Temperaturfaktor f_T zu berücksichtigen.
- Die Gehäusetemperatur darf $T_{max} = 90°C$ nicht übersteigen.

Übersicht der Nenn Drehmomente M_{n2} [Nm]																													
	[1]	3	4	5	6	7	9	10	12	15	16	20	25	28	30	35	36	40	45	48	50	60	64	70	75	80	81	84	90
TR 053		12	15	15	15	15	12	-	20	20	20	20	20	20	-	20	15	-	20	20	-	20	20	-	20	20	12	20	-
TR 060		18	25	25	25	25	18	18	30	30	30	30	30	30	18	30	25	30	-	30	30	-	30	30	30	30	-	30	18
TR 080		40	50	50	50	50	40	40	70	70	70	70	70	70	40	70	50	70	-	70	70	-	70	70	70	70	-	70	40
TR 105		100	140	140	140	140	100	100	170	170	170	170	170	170	100	170	140	170	-	170	170	-	170	170	170	170	-	170	100
TR 130		215	380	380	380	380	215	215	450	450	450	450	450	450	215	450	380	450	-	450	450	-	450	450	450	450	-	450	215
TR 160		350	500	500	500	500	350	350	700	700	700	700	700	700	350	700	500	700	-	700	700	-	700	700	700	700	-	700	350
TR 190		500	700	700	700	700	500	500	1000	1000	1000	1000	1000	1000	500	1000	700	1000	-	1000	1000	-	1000	1000	1000	1000	-	1000	500
	[1]	100	112	120	125	140	144	150	160	175	180	200	210	216	225	245	250	252	280	324	350	400	405	500	567	700	729	1000	
TR 053		20	20	-	20	20	20	-	-	20	20	-	-	20	20	20	-	20	-	20	-	-	20	-	20	-	12	-	
TR 060		18	-	30	30	30	-	30	30	30	-	30	30	30	-	-	30	-	30	-	30	30	-	30	-	30	-	18	
TR 080		40	-	70	70	70	-	70	70	70	-	70	70	70	-	-	70	-	70	-	70	70	-	70	-	70	-	40	
TR 105		100	-	170	170	170	-	170	170	170	-	170	170	170	-	-	170	-	170	-	170	170	-	170	-	170	-	100	
TR 130		215	-	450	450	450	-	450	450	450	-	450	450	450	-	-	450	-	450	-	450	450	-	450	-	450	-	215	
TR 160		350	-	500	500	500	-	500	500	500	-	500	500	500	-	-	500	-	500	-	500	500	-	500	-	500	-	350	
TR 190		500	-	700	700	700	-	700	700	700	-	700	700	700	-	-	700	-	700	-	700	700	-	700	-	700	-	500	

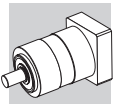

5.1 BESTELLBEZEICHNUNG

TR G 080 3 20 STD 95A CD 19 S1 OR SB KL UH1

SCHMIERSTOFF

- Standard

UH1 Lebensmitteltaugliches Schmiermittel

ABTRIEBSWELLENKONFIGURATION

KL Glatte Welle ohne Passfeder

KE Passfedernut (☉ MB)

LAGER DER ABTRIEBSWELLE

SB Standard

MONTAGEPOSITION

OR Horizontal

VA Vertikal mit Motor oben

VB Vertikal mit Motor unten

BETRIEBSART

S1 Dauerbetrieb

S5 Kurzzeitbetrieb

BOHRUNGSDURCHMESSER EINGANGSWELLE

6 ... 48 (☉ IS)

MOTORKOPPLUNG

CD Klemmnabe (☉ IS)

ANTRIEBSFLANSCH

25AH ... 180A1 Motorflansch

IS Eingangsvollwelle (TR 053 ... TR 160) (☉ G - ☉ MB)

FM Ohne Motorflansch

VERDREHSPIEL

STD

LOW

(☉ TR 053)

1 Getriebestufe	2 Getriebestufen	3 Getriebestufen (nur MB, G)	3 Getriebestufen	4 Getriebestufen (nur MB, G)
$\varphi_s \leq 5'$	$\varphi_s \leq 5'$	$\varphi_s \leq 5'$	$\varphi_s \leq 7'$	$\varphi_s \leq 7'$
$\varphi_R \leq 3'$	$\varphi_R \leq 3'$	$\varphi_R \leq 3'$	$\varphi_R \leq 5'$	$\varphi_R \leq 5'$

GETRIEBEÜBERSETZUNG

GETRIEBESTUFEN

1 2 3 4

BAUGRÖSSE

053 060 080 105 130 160 190

VERSION

- Koaxial

G Rechtwinkliger Eingang (TR 053 ... TR 160)

MB Rechtwinkliger Ausgang (TR 080 ... TR 160)

REIHE

TR

TR

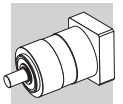

5.1.1 VERSIONEN UND ANTRIEBSSEITE

ANTRIEBSFLANSCH	VERSION	VERSION		
		Koaxial (—)	Rechtwinkliger Eingang (G)	Rechtwinkliger Ausgang (MB)
25AH ... 180A1				
IS			—	—
FM				

5.1.2 MONTAGEPOSITIONEN

	OR	VA	VB
—			
G			
MB			

TR

5.2 ZULÄSSIGE RADIAL- UND AXIALKRÄFTE FÜR DIE MB-VERSION

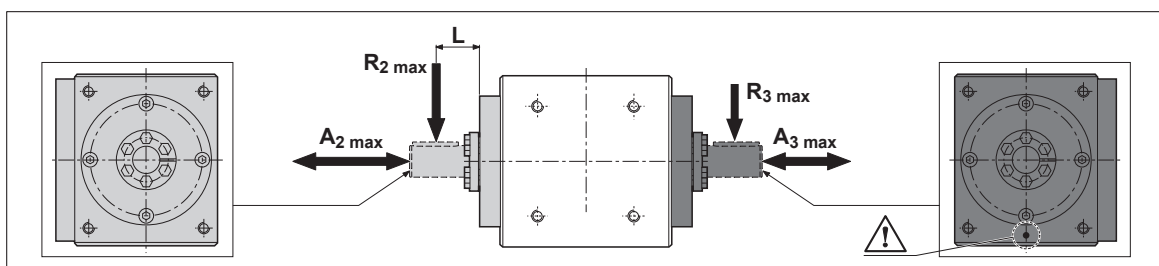

	R _{2 max} [N]	A _{2 max} [N]	L [mm]	R _{3 max} [N]	A _{3 max} [N]
TR MB 080	6000	5000	60	5500	5000
TR MB 105	9000	7500	80	7500	7500
TR MB 130	13500	11500	100	11000	11500
TR MB 160*	15000	11500	100	12500	11500

* Lager ausgelegt für eine durchschnittliche Lebensdauer von 10.000 Stunden unter normalen Betriebsbedingungen.



5.3 ABMESSUNGEN UND TECHNISCHE DATEN

TR 053

IS

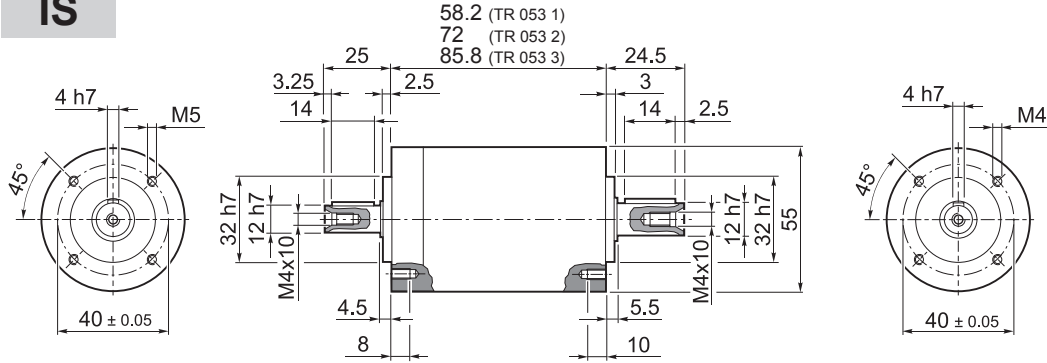

TR 053 1	0.8
TR 053 2	1.0
TR 053 3	1.3

25AH ... 80A

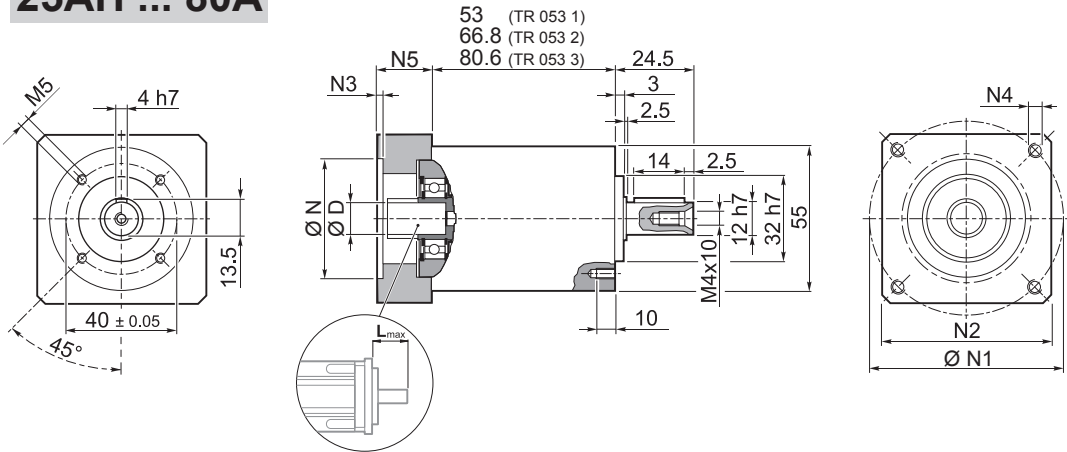

TR 053 1	0.8
TR 053 2	1.0
TR 053 3	1.3

											N	N1		N2	N3	N4	N5	L _{max}
	6	6.35	7	8	9	9.52	-	-	-	-		min	max					
25AH	6	6.35	7	8	9	9.52	-	-	-	-	25	36	48					
26AH	6	6.35	7	8	9	9.52	-	-	-	-	26	36	48					
28AH	6	6.35	7	8	9	9.52	-	-	-	-	28	36	48					
30AH	6	6.35	7	8	9	9.52	-	-	-	-	30	36	48					
32AH	6	6.35	7	8	9	9.52	-	-	-	-	32	38	48	55	3.5	4.5	25	25
34AH	6	6.35	7	8	9	9.52	-	-	-	-	34	40	48					
36AH	6	6.35	7	8	9	9.52	-	-	-	-	36	42	48					
38AH	6	6.35	7	8	9	9.52	-	-	-	-	38	44	48					
40AH	6	6.35	7	8	9	9.52	-	-	-	-	40	46	48					
38B	6	6.35	7	8	9	9.52	10	11	12	12.7	38.1	66.6		60	3	M4x10	18	25
40B	6	6.35	7	8	9	9.52	10	11	12	12.7	40	63	60	3	M4x10	18	25	
50A	6	6.35	7	8	9	9.52	10	11	12	12.7	50	60	60	3	M4x10	18	25	
50B	6	6.35	7	8	9	9.52	10	11	12	12.7	14	50	65	60	3	M5x12	23	30
50BH	6	6.35	7	8	9	9.52	10	11	12	12.7	14	50	65	60	4	5.5	23	30
50C	6	6.35	7	8	9	9.52	10	11	12	12.7	14	50	70	60	3	M4x10	23	30
50MH	6	6.35	7	8	9	9.52	10	11	12	12.7	-	50	65	55	2	5.5	16	23
60A	6	6.35	7	8	9	9.52	10	11	12	12.7	-	60	75	65	3	M5x12	18	25
60AH	6	6.35	7	8	9	9.52	10	11	12	12.7	-	60	75	65	3	5.5	18	25
60A1	6	6.35	7	8	9	9.52	10	11	12	12.7	14	60	75	65	3	M5x12	23	30
60AH1	6	6.35	7	8	9	9.52	10	11	12	12.7	14	60	75	65	3	5.5	23	30
60B	6	6.35	7	8	9	9.52	10	11	12	12.7	14	60	85	75	3	M5x12	23	30
60C	6	6.35	7	8	9	9.52	10	11	12	12.7	14	60	90	75	3	M5x12	23	30
70A	6	6.35	7	8	9	9.52	10	11	12	12.7	14	70	85	75	3	M6x15	23	30
70B	6	6.35	7	8	9	9.52	10	11	12	12.7	14	70	90	75	3	M5x12	23	30
73A	6	6.35	7	8	9	9.52	10	11	12	12.7	14	73	98.4	85	3	M5x12	25	32
80A	6	6.35	7	8	9	9.52	10	11	12	12.7	14	80	100	85	3	M6x15	23	30

Für weitere Motoradapter und Antriebswellenbohrungen bitte nachfragen.

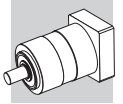

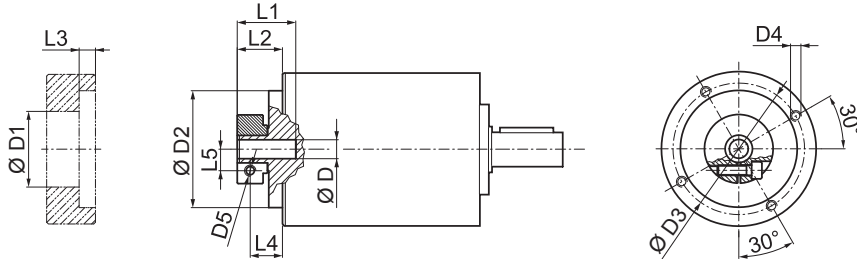

TR 053

FM

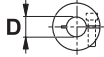

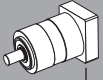
				D1	D2	D3	D4	D5	L1	L2	L3	L4	L5
6	6.35	7		32.5	50	42.5	M4x8	M4	20.2	13.2	3	8.7	8
8	9	9.52	10	32.5	50	42.5	M4x8	M4	20.2	13.2	3	7.8	9
11	12	12.7		35.5	50	42.5	M4x8	M4	20.5	13.5	3	8.5	11
14				35.5	50	42.5	M4x8	M4	24	17	3	10.2	11.5

	M_{n2}	M_{a2}	M_{p2}	n_1	$n_{1\max}$	φ_s	C_t	$R_{1\max}$	$R_{2\max}$	$A_{2\max}$	η	J_G [kgcm ²]	
												D 	
i	[Nm]	[Nm]	[Nm]	[min ⁻¹]	[min ⁻¹]	[arcmin]	$\frac{Nm}{arcmin}$	[N]	[N]	[N]	%	6 ... 9.52	10 ... 14
TR 053 1_3	12	22	40	3300	4000	5'	1.0	200	500	600	97	0.06	0.08
TR 053 1_4	15	28	45	3500	5000	5'	1.0	200	500	600	97	0.05	0.06
TR 053 1_5	15	28	45	3500	5000	5'	1.0	200	500	600	97	0.04	0.06
TR 053 1_6	15	28	45	3500	5000	5'	1.0	200	500	600	97	0.03	0.05
TR 053 1_7	15	28	45	4000	6000	5'	1.0	200	500	600	97	0.03	0.05
TR 053 1_9	12	22	40	4000	6000	5'	1.0	200	500	600	97	0.03	0.05
TR 053 2_12	20	30	60	3300	4000	5'	0.9	200	500	600	94	0.06	0.08
TR 053 2_15	20	30	60	3300	4000	5'	0.9	200	500	600	94	0.06	0.08
TR 053 2_16	20	30	60	3500	5000	5'	0.9	200	500	600	94	0.05	0.06
TR 053 2_20	20	30	60	3500	5000	5'	0.9	200	500	600	94	0.04	0.06
TR 053 2_25	20	30	60	3500	5000	5'	0.9	200	500	600	94	0.04	0.06
TR 053 2_28	20	30	60	4000	6000	5'	0.9	200	500	600	94	0.03	0.05
TR 053 2_35	20	30	60	4000	6000	5'	0.9	200	500	600	94	0.03	0.05
TR 053 2_36	15	28	45	4000	6000	5'	0.9	200	500	600	94	0.03	0.05
TR 053 2_45	20	30	60	4000	6000	5'	0.9	200	500	600	94	0.03	0.05
TR 053 2_81	12	22	40	4000	6000	5'	0.9	200	500	600	94	0.03	0.05
TR 053 3_48	20	30	60	4000	5000	7'	0.7	200	500	600	91	0.05	0.07
TR 053 3_60	20	30	60	3500	5000	7'	0.7	200	500	600	91	0.05	0.07
TR 053 3_64	20	30	60	3500	5000	7'	0.7	200	500	600	91	0.05	0.06
TR 053 3_75	20	30	60	3500	5000	7'	0.7	200	500	600	91	0.04	0.06
TR 053 3_80	20	30	60	3500	5000	7'	0.7	200	500	600	91	0.05	0.06
TR 053 3_84	20	30	60	4000	6000	7'	0.7	200	500	600	91	0.03	0.05
TR 053 3_100	20	30	60	3500	5000	7'	0.7	200	500	600	91	0.04	0.06
TR 053 3_112	20	30	60	4000	6000	7'	0.7	200	500	600	91	0.03	0.05
TR 053 3_125	20	30	60	3500	5000	7'	0.7	200	500	600	91	0.04	0.06
TR 053 3_140	20	30	60	4000	6000	7'	0.7	200	500	600	91	0.03	0.05
TR 053 3_144	20	30	60	4000	6000	7'	0.7	200	500	600	91	0.03	0.05
TR 053 3_175	20	30	60	4000	6000	7'	0.7	200	500	600	91	0.03	0.05
TR 053 3_180	20	30	60	4000	6000	7'	0.7	200	500	600	91	0.03	0.05
TR 053 3_216	20	30	60	3500	5000	7'	0.7	200	500	600	91	0.03	0.05
TR 053 3_225	20	30	60	4000	6000	7'	0.7	200	500	600	91	0.03	0.05
TR 053 3_245	20	30	60	4000	6000	7'	0.7	200	500	600	91	0.03	0.05
TR 053 3_252	20	30	60	4000	6000	7'	0.7	200	500	600	91	0.05	0.06
TR 053 3_324	20	30	60	4000	6000	7'	0.7	200	500	600	91	0.03	0.05
TR 053 3_405	20	30	60	4000	6000	7'	0.7	200	500	600	91	0.03	0.05
TR 053 3_567	20	30	60	4000	6000	7'	0.7	200	500	600	91	0.03	0.05
TR 053 3_729	12	22	40	4000	6000	7'	0.7	200	500	600	91	0.03	0.05

TR



TR G 053

25AH ... 80A

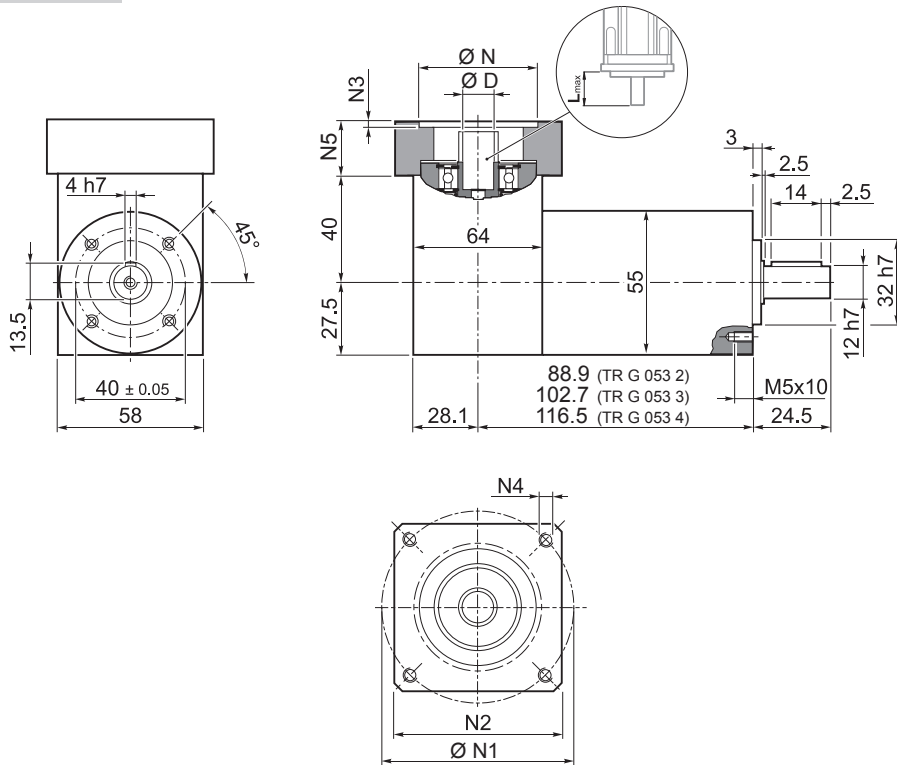

TR G 053 2	1.3
TR G 053 3	1.5
TR G 053 4	1.8

TR

												N	N1		N2	N3	N4	N5	L _{max}
	min	max	min	max															
25AH	6	6.35	7	8	9	9.52	-	-	-	-	-	25	36	48					
26AH	6	6.35	7	8	9	9.52	-	-	-	-	-	26	36	48					
28AH	6	6.35	7	8	9	9.52	-	-	-	-	-	28	36	48					
30AH	6	6.35	7	8	9	9.52	-	-	-	-	-	30	36	48					
32AH	6	6.35	7	8	9	9.52	-	-	-	-	-	32	38	48	55	3.5	4.5	25	25
34AH	6	6.35	7	8	9	9.52	-	-	-	-	-	34	40	48					
36AH	6	6.35	7	8	9	9.52	-	-	-	-	-	36	42	48					
38AH	6	6.35	7	8	9	9.52	-	-	-	-	-	38	44	48					
40AH	6	6.35	7	8	9	9.52	-	-	-	-	-	40	46	48					
38B	6	6.35	7	8	9	9.52	10	11	12	12.7	-	38.1	66.6	60	3	M4x10	18	25	
40B	6	6.35	7	8	9	9.52	10	11	12	12.7	-	40	63	60	3	M4x10	18	25	
50A	6	6.35	7	8	9	9.52	10	11	12	12.7	-	50	60	60	3	M4x10	18	25	
50B	6	6.35	7	8	9	9.52	10	11	12	12.7	14	50	65	60	3	M5x12	23	30	
50BH	6	6.35	7	8	9	9.52	10	11	12	12.7	14	50	65	60	4	5.5	23	30	
50C	6	6.35	7	8	9	9.52	10	11	12	12.7	14	50	70	60	3	M4x10	23	30	
50MH	6	6.35	7	8	9	9.52	10	11	12	12.7	-	50	65	55	2	5.5	16	23	
60A	6	6.35	7	8	9	9.52	10	11	12	12.7	-	60	75	65	3	M5x12	18	25	
60A1	6	6.35	7	8	9	9.52	10	11	12	12.7	14	60	75	65	3	M5x12	23	30	
60B	6	6.35	7	8	9	9.52	10	11	12	12.7	14	60	85	75	3	M5x12	23	30	
60C	6	6.35	7	8	9	9.52	10	11	12	12.7	14	60	90	75	3	M5x12	23	30	
70A	6	6.35	7	8	9	9.52	10	11	12	12.7	14	70	85	75	3	M6x15	23	30	
70B	6	6.35	7	8	9	9.52	10	11	12	12.7	14	70	90	75	3	M5x12	23	30	
73A	6	6.35	7	8	9	9.52	10	11	12	12.7	14	73	98.4	85	3	M5x12	25	32	
80A	6	6.35	7	8	9	9.52	10	11	12	12.7	14	80	100	85	3	M6x15	23	30	

Für weitere Motoradapter und Antriebswellenbohrungen bitte nachfragen.

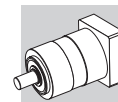

TR G 053

FM

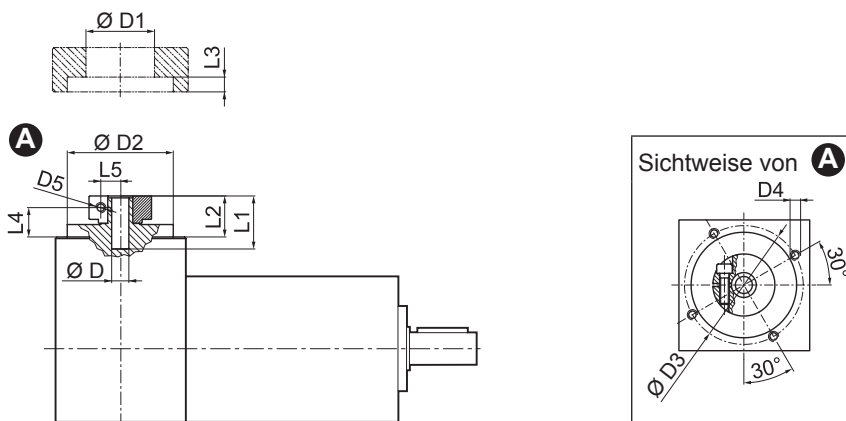

D				D1	D2	D3	D4	D5	L1	L2	L3	L4	L5
6	6.35	7		32.5	50	42.5	M4x8	M4	20.2	13.2	3	8.7	8
8	9	9.52	10	32.5	50	42.5	M4x8	M4	20.2	13.2	3	7.8	9
11	12	12.7		35.5	50	42.5	M4x8	M4	20.5	13.5	3	8.5	11
14				35.5	50	42.5	M4x8	M4	24	17	3	10.2	11.5

i	M _{n 2}	M _{a 2}	M _{p 2}	n ₁	n _{1 max}	φ _S	C _t	R _{2 max}	A _{2 max}	%	J _G [kgcm ²]	
	[Nm]	[Nm]	[Nm]	[min ⁻¹]	[min ⁻¹]	[arcmin]	$\left[\frac{Nm}{arcmin} \right]$	[N]	[N]		6 ... 9.52	10 ... 14
TR G 053 2_3	12	22	40	3300	4000	5'	1.0	500	600	94	0.18	0.20
TR G 053 2_4	15	28	45	3500	5000	5'	1.0	500	600	94	0.18	0.19
TR G 053 2_5	15	28	45	3500	5000	5'	1.0	500	600	94	0.17	0.19
TR G 053 2_6	15	28	45	3500	5000	5'	1.0	500	600	94	0.17	0.18
TR G 053 2_7	15	28	45	4000	6000	5'	1.0	500	600	94	0.17	0.19
TR G 053 2_9	12	22	40	4000	6000	5'	1.0	500	600	94	0.17	0.18
TR G 053 3_12	20	30	60	3300	4000	5'	0.9	500	600	91	0.18	0.20
TR G 053 3_15	20	30	60	3300	4000	5'	0.9	500	600	91	0.18	0.20
TR G 053 3_16	20	30	60	3500	5000	5'	0.9	500	600	91	0.17	0.19
TR G 053 3_20	20	30	60	3500	5000	5'	0.9	500	600	91	0.17	0.19
TR G 053 3_25	20	30	60	3500	5000	5'	0.9	500	600	91	0.17	0.19
TR G 053 3_28	20	30	60	4000	6000	5'	0.9	500	600	91	0.17	0.19
TR G 053 3_35	20	30	60	4000	6000	5'	0.9	500	600	91	0.17	0.19
TR G 053 3_36	15	28	45	4000	6000	5'	0.9	500	600	91	0.17	0.18
TR G 053 3_45	20	30	60	4000	6000	5'	0.9	500	600	91	0.17	0.19
TR G 053 3_81	12	22	40	4000	6000	5'	0.9	500	600	91	0.17	0.18
TR G 053 4_48	20	30	60	4000	5000	7'	0.7	500	600	89	0.18	0.19
TR G 053 4_60	20	30	60	3500	5000	7'	0.7	500	600	89	0.18	0.19
TR G 053 4_64	20	30	60	3500	5000	7'	0.7	500	600	89	0.17	0.19
TR G 053 4_75	20	30	60	3500	5000	7'	0.7	500	600	89	0.17	0.19
TR G 053 4_80	20	30	60	3500	5000	7'	0.7	500	600	89	0.17	0.19
TR G 053 4_84	20	30	60	4000	6000	7'	0.7	500	600	89	0.17	0.19
TR G 053 4_100	20	30	60	3500	5000	7'	0.7	500	600	89	0.17	0.19
TR G 053 4_112	20	30	60	4000	6000	7'	0.7	500	600	89	0.17	0.19
TR G 053 4_125	20	30	60	3500	5000	7'	0.7	500	600	89	0.17	0.19
TR G 053 4_140	20	30	60	4000	6000	7'	0.7	500	600	89	0.17	0.19
TR G 053 4_144	20	30	60	4000	6000	7'	0.7	500	600	89	0.17	0.18
TR G 053 4_175	20	30	60	4000	6000	7'	0.7	500	600	89	0.17	0.19
TR G 053 4_180	20	30	60	4000	6000	7'	0.7	500	600	89	0.17	0.18
TR G 053 4_216	20	30	60	3500	5000	7'	0.7	500	600	89	0.17	0.18
TR G 053 4_225	20	30	60	4000	6000	7'	0.7	500	600	89	0.17	0.18
TR G 053 4_245	20	30	60	4000	6000	7'	0.7	500	600	89	0.17	0.19
TR G 053 4_252	20	30	60	4000	6000	7'	0.7	500	600	89	0.18	0.20
TR G 053 4_324	20	30	60	4000	6000	7'	0.7	500	600	89	0.17	0.18
TR G 053 4_405	20	30	60	4000	6000	7'	0.7	500	600	89	0.17	0.18
TR G 053 4_567	20	30	60	4000	6000	7'	0.7	500	600	89	0.17	0.18
TR G 053 4_729	12	22	40	4000	6000	7'	0.7	500	600	89	0.17	0.18

TR



TR 060

IS

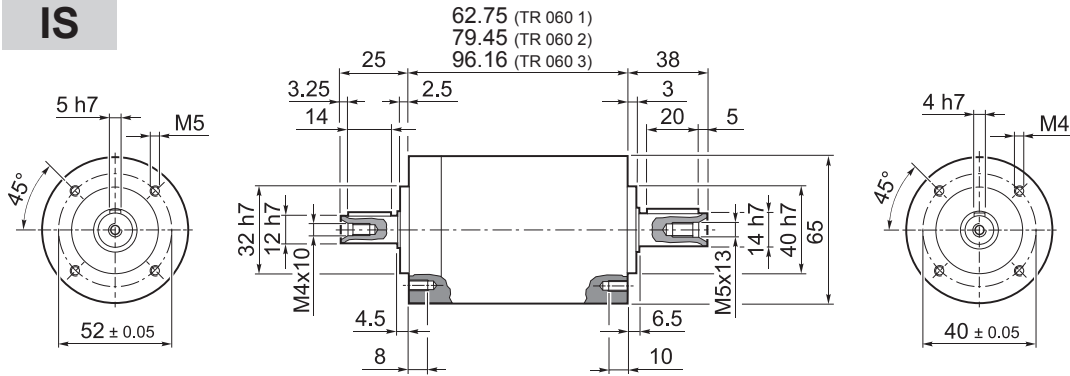

	Kg
TR 060 1	1.2
TR 060 2	1.7
TR 060 3	2.0

25AH ... 80A

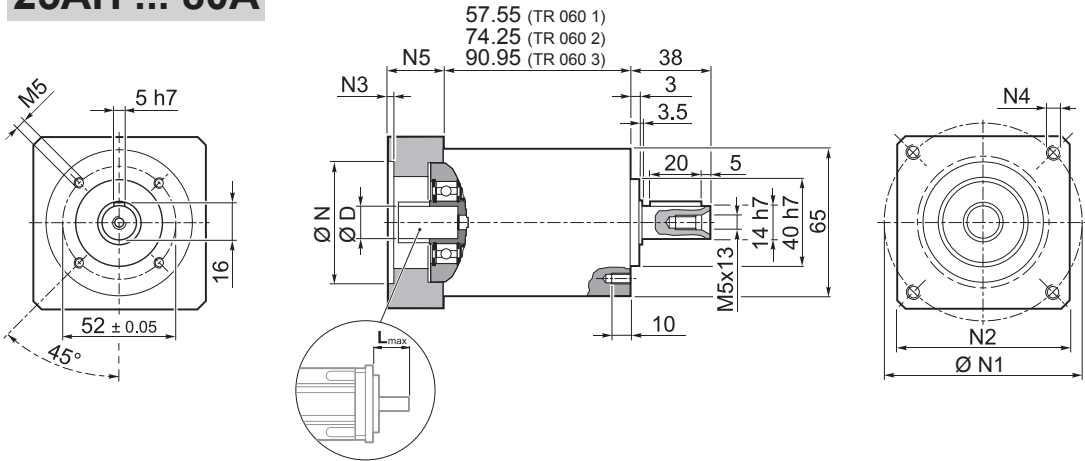

	Kg
TR 060 1	1.2
TR 060 2	1.7
TR 060 3	2.0

	D													N	N1		N2	N3	N4	N5	Lmax
	6	6.35	7	8	9	9.52	-	-	-	-	-	-	-		min	max					
25AH	6	6.35	7	8	9	9.52	-	-	-	-	-	-	25	39	56						
26AH	6	6.35	7	8	9	9.52	-	-	-	-	-	-	26	39	56						
28AH	6	6.35	7	8	9	9.52	-	-	-	-	-	-	28	39	56						
30AH	6	6.35	7	8	9	9.52	-	-	-	-	-	-	30	39	56						
32AH	6	6.35	7	8	9	9.52	-	-	-	-	-	-	32	39	56	65	3.5	4.5	25	25	
34AH	6	6.35	7	8	9	9.52	-	-	-	-	-	-	34	40	56						
36AH	6	6.35	7	8	9	9.52	-	-	-	-	-	-	36	42	56						
39AH	6	6.35	7	8	9	9.52	-	-	-	-	-	-	39	45	56						
40AH	6	6.35	7	8	9	9.52	-	-	-	-	-	-	40	46	56						
38B	6	6.35	7	8	9	9.52	10	11	12	12.7	-	-	38.1	66.6		60	3	M4x10	18	25	
40B	6	6.35	7	8	9	9.52	10	11	12	12.7	-	-	40	63		60	3	M4x10	18	25	
50A	6	6.35	7	8	9	9.52	10	11	12	12.7	-	-	50	60		60	3	M4x10	18	25	
50B	6	6.35	7	8	9	9.52	10	11	12	12.7	14	-	50	65		60	3	M5x12	23	30	
50BH	6	6.35	7	8	9	9.52	10	11	12	12.7	14	-	50	65		65	3	5.5	25	32	
50C	6	6.35	7	8	9	9.52	10	11	12	12.7	14	-	50	70		60	3	M4x10	23	30	
55MH	6	6.35	7	8	9	9.52	10	11	12	12.7	-	-	55	80		65	2	5.5	16	23	
60A	6	6.35	7	8	9	9.52	10	11	12	12.7	-	-	60	75		65	3	M5x12	18	25	
60AH	6	6.35	7	8	9	9.52	10	11	12	12.7	-	-	60	75		65	3	5.5	18	25	
60A1	6	6.35	7	8	9	9.52	10	11	12	12.7	14	-	60	75		65	3	M5x12	23	30	
60AH1	6	6.35	7	8	9	9.52	10	11	12	12.7	14	-	60	75		65	3	5.5	23	30	
60B	6	6.35	7	8	9	9.52	10	11	12	12.7	14	-	60	85		75	3	M5x12	23	30	
60C	6	6.35	7	8	9	9.52	10	11	12	12.7	14	-	60	90		75	3	M5x12	23	30	
70A	6	6.35	7	8	9	9.52	10	11	12	12.7	14	-	70	85		75	3	M6x15	23	30	
70B	6	6.35	7	8	9	9.52	10	11	12	12.7	14	-	70	90		75	3	M5x12	23	30	
73A	6	6.35	7	8	9	9.52	10	11	12	12.7	14	-	73	98.4		85	3	M5x12	25	32	
80A	6	6.35	7	8	9	9.52	10	11	12	12.7	14	-	80	100		85	3	M6x15	23	30	

Für weitere Motoradapter und Antriebswellenbohrungen bitte nachfragen.

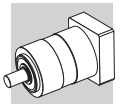

TR 060

FM

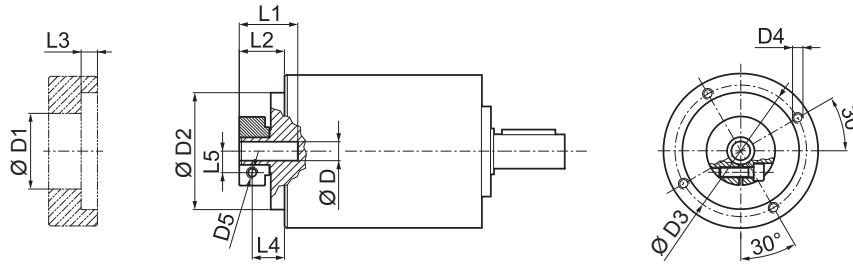

D				D1	D2	D3	D4	D5	L1	L2	L3	L4	L5
6	6.35	7		32.5	50	42.5	M4x8	M4	20.2	13.2	3	8.7	8
8	9	9.52	10	32.5	50	42.5	M4x8	M4	20.2	13.2	3	7.8	9
11	12	12.7		35.5	50	42.5	M4x8	M4	20.5	13.5	3	8.5	11
14				35.5	50	42.5	M4x8	M4	24	17	3	10.2	11.5

i	M _{n2} [Nm]	M _{a2} [Nm]	M _{p2} [Nm]	n ₁ [min ⁻¹]	n _{1 max} [min ⁻¹]	Ψ _S [arcmin]	Ψ _R [arcmin]	C _t [Nm/arcmin]	R _{1 max} [N]	R _{2 max} [N]	A _{2 max} [N]	η %	J _G [kgcm ²]	
													6 ... 9.52	10 ... 14
TR 060 1_3	18	35	70	3300	4000	5'	3'	3.0	200	600	700	97	0.10	0.11
TR 060 1_4	25	40	90	3500	5000	5'	3'	3.0	200	600	700	97	0.06	0.08
TR 060 1_5	25	40	90	3500	5000	5'	3'	3.0	200	600	700	97	0.05	0.07
TR 060 1_6	25	40	90	3500	5000	5'	3'	3.0	200	600	700	97	0.04	0.06
TR 060 1_7	25	40	90	4000	6000	5'	3'	3.0	200	600	700	97	0.04	0.06
TR 060 1_10	18	35	70	4000	6000	5'	3'	3.0	200	600	700	97	0.03	0.05
TR 060 2_9	18	35	70	3300	4000	5'	3'	2.5	200	600	700	94	0.10	0.12
TR 060 2_12	30	45	100	3300	4000	5'	3'	2.5	200	600	700	94	0.10	0.11
TR 060 2_15	30	45	100	3300	4000	5'	3'	2.5	200	600	700	94	0.09	0.11
TR 060 2_16	30	45	100	3500	5000	5'	3'	2.5	200	600	700	94	0.06	0.08
TR 060 2_20	30	45	100	3500	5000	5'	3'	2.5	200	600	700	94	0.05	0.07
TR 060 2_25	30	45	100	3500	5000	5'	3'	2.5	200	600	700	94	0.05	0.06
TR 060 2_28	30	45	100	4000	6000	5'	3'	2.5	200	600	700	94	0.04	0.06
TR 060 2_30	18	35	70	4000	6000	5'	3'	2.5	200	600	700	94	0.03	0.05
TR 060 2_35	30	45	100	4000	6000	5'	3'	2.5	200	600	700	94	0.04	0.06
TR 060 2_36	25	40	90	3500	5000	5'	3'	2.5	200	600	700	94	0.04	0.06
TR 060 2_40	30	45	100	4000	6000	5'	3'	2.5	200	600	700	94	0.03	0.05
TR 060 2_50	30	45	100	4000	6000	5'	3'	2.5	200	600	700	94	0.03	0.05
TR 060 2_70	30	45	100	4000	6000	5'	3'	2.5	200	600	700	94	0.03	0.05
TR 060 2_100	18	35	70	4000	6000	5'	3'	2.5	200	600	700	94	0.03	0.05
TR 060 3_48	30	45	100	3500	5000	7'	5'	2.0	200	600	700	91	0.06	0.08
TR 060 3_64	30	45	100	3500	5000	7'	5'	2.0	200	600	700	91	0.06	0.08
TR 060 3_75	30	45	100	3500	5000	7'	5'	2.0	200	600	700	91	0.05	0.07
TR 060 3_80	30	45	100	3500	5000	7'	5'	2.0	200	600	700	91	0.06	0.08
TR 060 3_84	30	45	100	4000	6000	7'	5'	2.0	200	600	700	91	0.04	0.06
TR 060 3_90	18	35	70	4000	6000	7'	5'	2.0	200	600	700	91	0.03	0.05
TR 060 3_120	30	45	100	4000	6000	7'	5'	2.0	200	600	700	91	0.03	0.05
TR 060 3_125	30	45	100	3500	5000	7'	5'	2.0	200	600	700	91	0.05	0.07
TR 060 3_140	30	45	100	4000	6000	7'	5'	2.0	200	600	700	91	0.04	0.06
TR 060 3_150	30	45	100	4000	6000	7'	5'	2.0	200	600	700	91	0.03	0.05
TR 060 3_160	30	45	100	4000	6000	7'	5'	2.0	200	600	700	91	0.03	0.05
TR 060 3_175	30	45	100	4000	6000	7'	5'	2.0	200	600	700	91	0.04	0.06
TR 060 3_200	30	45	100	4000	6000	7'	5'	2.0	200	600	700	91	0.03	0.05
TR 060 3_210	30	45	100	4000	6000	7'	5'	2.0	200	600	700	91	0.03	0.05
TR 060 3_216	30	45	100	3500	5000	7'	5'	2.0	200	600	700	91	0.04	0.06
TR 060 3_250	30	45	100	4000	6000	7'	5'	2.0	200	600	700	91	0.03	0.05
TR 060 3_280	30	45	100	4000	6000	7'	5'	2.0	200	600	700	91	0.03	0.05
TR 060 3_350	30	45	100	4000	6000	7'	5'	2.0	200	600	700	91	0.03	0.05
TR 060 3_400	30	45	100	4000	6000	7'	5'	2.0	200	600	700	91	0.03	0.05
TR 060 3_500	30	45	100	4000	6000	7'	5'	2.0	200	600	700	91	0.03	0.05
TR 060 3_700	30	45	100	4000	6000	7'	5'	2.0	200	600	700	91	0.03	0.05
TR 060 3_1000	18	35	70	4000	6000	7'	5'	2.0	200	600	700	91	0.03	0.05

TR



TR G 060

25AH ... 80A

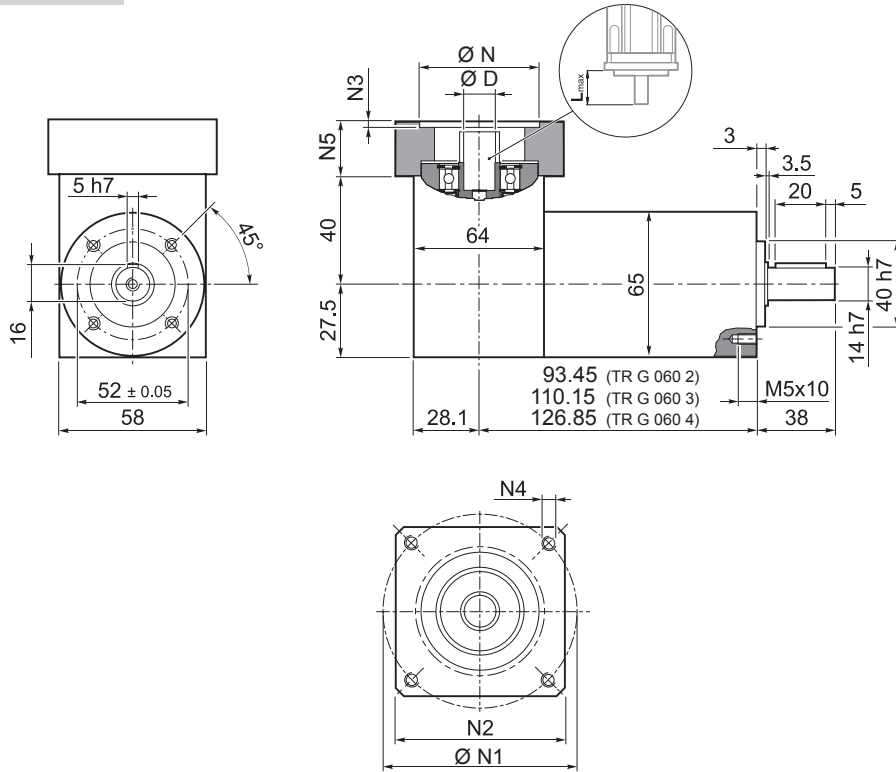

	
TR G 060 2	1.7
TR G 060 3	2.2
TR G 060 4	2.5

TR

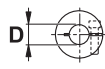
			N	N1		N2	N3	N4	N5	L _{max}								
				min	max													
25AH	6	6.35	7	8	9	9.52	-	-	-	-	25	39	56					
26AH	6	6.35	7	8	9	9.52	-	-	-	-	26	39	56					
28AH	6	6.35	7	8	9	9.52	-	-	-	-	28	39	56					
30AH	6	6.35	7	8	9	9.52	-	-	-	-	30	39	56					
32AH	6	6.35	7	8	9	9.52	-	-	-	-	32	39	56	65	3.5	4.5	25	25
34AH	6	6.35	7	8	9	9.52	-	-	-	-	34	40	56					
36AH	6	6.35	7	8	9	9.52	-	-	-	-	36	42	56					
39AH	6	6.35	7	8	9	9.52	-	-	-	-	39	45	56					
40AH	6	6.35	7	8	9	9.52	-	-	-	-	40	46	56					
38B	6	6.35	7	8	9	9.52	10	11	12	12.7	-	38.1	66.6	60	3	M4x10	18	25
40B	6	6.35	7	8	9	9.52	10	11	12	12.7	-	40	63	60	3	M4x10	18	25
50A	6	6.35	7	8	9	9.52	10	11	12	12.7	-	50	60	60	3	M4x10	18	25
50B	6	6.35	7	8	9	9.52	10	11	12	12.7	14	50	65	60	3	M5x12	23	30
50BH	6	6.35	7	8	9	9.52	10	11	12	12.7	14	50	65	65	3	5.5	25	32
50C	6	6.35	7	8	9	9.52	10	11	12	12.7	14	50	70	60	3	M4x10	23	30
55MH	6	6.35	7	8	9	9.52	10	11	12	12.7	-	55	80	65	2	5.5	16	23
60A	6	6.35	7	8	9	9.52	10	11	12	12.7	-	60	75	65	3	M5x12	18	25
60A1	6	6.35	7	8	9	9.52	10	11	12	12.7	14	60	75	65	3	M5x12	23	30
60B	6	6.35	7	8	9	9.52	10	11	12	12.7	14	60	85	75	3	M5x12	23	30
60C	6	6.35	7	8	9	9.52	10	11	12	12.7	14	60	90	75	3	M5x12	23	30
70A	6	6.35	7	8	9	9.52	10	11	12	12.7	14	70	85	75	3	M6x15	23	30
70B	6	6.35	7	8	9	9.52	10	11	12	12.7	14	70	90	75	3	M5x12	23	30
73A	6	6.35	7	8	9	9.52	10	11	12	12.7	14	73	98.4	85	3	M5x12	25	32
80A	6	6.35	7	8	9	9.52	10	11	12	12.7	14	80	100	85	3	M6x15	23	30

Für weitere Motoradapter und Antriebswellenbohrungen bitte nachfragen.

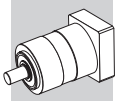

TR G 060

FM

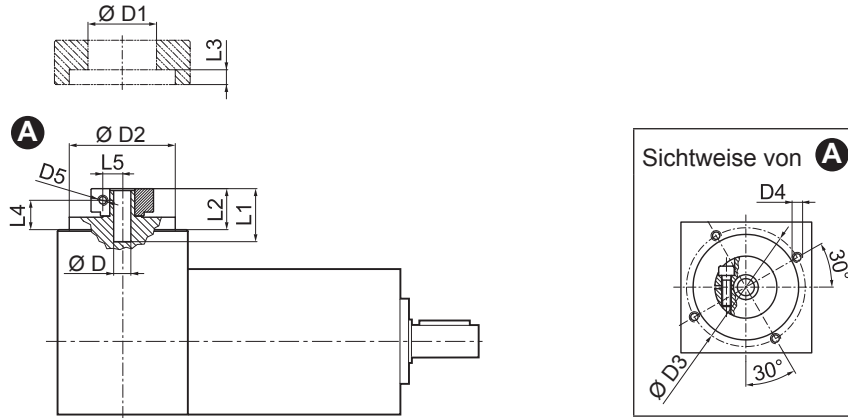

				D1	D2	D3	D4	D5	L1	L2	L3	L4	L5
6	6.35	7		32.5	50	42.5	M4x8	M4	20.2	13.2	3	8.7	8
8	9	9.52	10	32.5	50	42.5	M4x8	M4	20.2	13.2	3	7.8	9
11	12	12.7		35.5	50	42.5	M4x8	M4	20.5	13.5	3	8.5	11
14				35.5	50	42.5	M4x8	M4	24	17	3	10.2	11.5

	i	M _{n 2}	M _{a 2}	M _{p 2}	n ₁	n _{1 max}	φ _S	φ _R	C _t	R _{2 max}	A _{2 max}	η	J _G [kgcm ²]	
		[Nm]	[Nm]	[Nm]	[min ⁻¹]	[min ⁻¹]	[arcmin]	[arcmin]	$\left[\frac{Nm}{arcmin} \right]$	[N]	[N]	%		6 ... 9.52
TR G 060 2_3		18	35	70	3300	4000	5'	3'	3.0	600	700	94	0.20	0.20
TR G 060 2_4		25	40	90	3500	5000	5'	3'	3.0	600	700	94	0.18	0.20
TR G 060 2_5		25	40	90	3500	5000	5'	3'	3.0	600	700	94	0.17	0.19
TR G 060 2_6		25	40	90	3500	5000	5'	3'	3.0	600	700	94	0.17	0.19
TR G 060 2_7		25	40	90	4000	6000	5'	3'	3.0	600	700	94	0.17	0.19
TR G 060 2_10		18	35	70	4000	6000	5'	3'	3.0	600	700	94	0.17	0.18
TR G 060 3_9		18	35	70	3300	4000	5'	3'	2.5	600	700	91	0.20	0.21
TR G 060 3_12		30	45	100	3300	4000	5'	3'	2.5	600	700	91	0.20	0.21
TR G 060 3_15		30	45	100	3300	4000	5'	3'	2.5	600	700	91	0.19	0.21
TR G 060 3_16		30	45	100	3500	5000	5'	3'	2.5	600	700	91	0.18	0.20
TR G 060 3_20		30	45	100	3500	5000	5'	3'	2.5	600	700	91	0.17	0.19
TR G 060 3_25		30	45	100	3500	5000	5'	3'	2.5	600	700	91	0.17	0.18
TR G 060 3_28		30	45	100	4000	6000	5'	3'	2.5	600	700	91	0.17	0.19
TR G 060 3_30		18	35	70	4000	6000	5'	3'	2.5	600	700	91	0.17	0.18
TR G 060 3_35		30	45	100	4000	6000	5'	3'	2.5	600	700	91	0.18	0.19
TR G 060 3_36		25	40	90	3500	5000	5'	3'	2.5	600	700	91	0.18	0.19
TR G 060 3_40		30	45	100	4000	6000	5'	3'	2.5	600	700	91	0.17	0.18
TR G 060 3_50		30	45	100	4000	6000	5'	3'	2.5	600	700	91	0.17	0.18
TR G 060 3_70		30	45	100	4000	6000	5'	3'	2.5	600	700	91	0.17	0.18
TR G 060 3_100		18	35	70	4000	6000	5'	3'	2.5	600	700	91	0.17	0.18
TR G 060 4_48		30	45	100	3500	5000	7'	5'	2.0	600	700	89	0.18	0.20
TR G 060 4_64		30	45	100	3500	5000	7'	5'	2.0	600	700	89	0.18	0.20
TR G 060 4_75		30	45	100	3500	5000	7'	5'	2.0	600	700	89	0.17	0.19
TR G 060 4_80		30	45	100	3500	5000	7'	5'	2.0	600	700	89	0.18	0.20
TR G 060 4_84		30	45	100	4000	6000	7'	5'	2.0	600	700	89	0.17	0.19
TR G 060 4_90		18	35	70	4000	6000	7'	5'	2.0	600	700	89	0.17	0.18
TR G 060 4_120		30	45	100	4000	6000	7'	5'	2.0	600	700	89	0.15	0.17
TR G 060 4_125		30	45	100	3500	5000	7'	5'	2.0	600	700	89	0.17	0.19
TR G 060 4_140		30	45	100	4000	6000	7'	5'	2.0	600	700	89	0.17	0.19
TR G 060 4_150		30	45	100	4000	6000	7'	5'	2.0	600	700	89	0.17	0.18
TR G 060 4_160		30	45	100	4000	6000	7'	5'	2.0	600	700	89	0.17	0.18
TR G 060 4_175		30	45	100	4000	6000	7'	5'	2.0	600	700	89	0.17	0.19
TR G 060 4_200		30	45	100	4000	6000	7'	5'	2.0	600	700	89	0.17	0.18
TR G 060 4_210		30	45	100	4000	6000	7'	5'	2.0	600	700	89	0.17	0.18
TR G 060 4_216		30	45	100	3500	5000	7'	5'	2.0	600	700	89	0.17	0.19
TR G 060 4_250		30	45	100	4000	6000	7'	5'	2.0	600	700	89	0.17	0.18
TR G 060 4_280		30	45	100	4000	6000	7'	5'	2.0	600	700	89	0.17	0.18
TR G 060 4_350		30	45	100	4000	6000	7'	5'	2.0	600	700	89	0.17	0.18
TR G 060 4_400		30	45	100	4000	6000	7'	5'	2.0	600	700	89	0.17	0.18
TR G 060 4_500		30	45	100	4000	6000	7'	5'	2.0	600	700	89	0.17	0.18
TR G 060 4_700		30	45	100	4000	6000	7'	5'	2.0	600	700	89	0.17	0.18
TR G 060 4_1000		18	35	70	4000	6000	7'	5'	2.0	600	700	89	0.17	0.18

TR



TR 080

IS

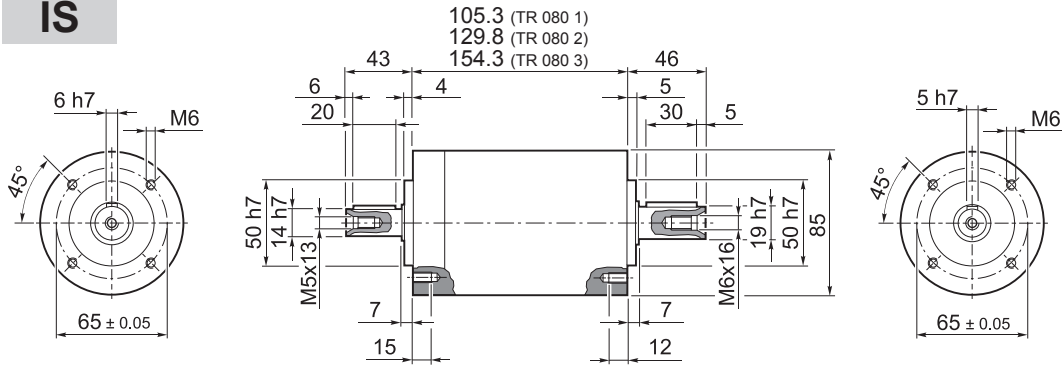

TR 080 1	4.0
TR 080 2	4.6
TR 080 3	5.2

40B1 ... 110B1

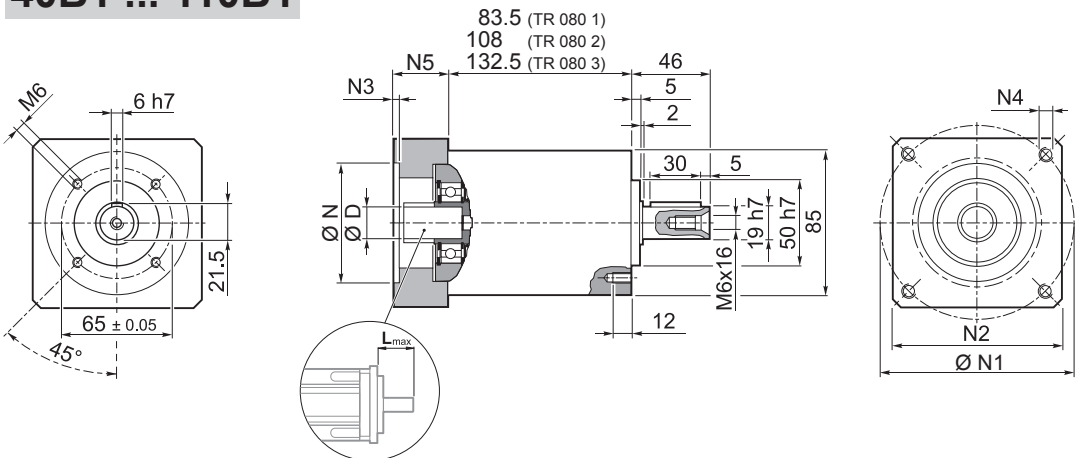

TR 080 1	4.0
TR 080 2	4.6
TR 080 3	5.2

											N	N1	N2	N3	N4	N5	L _{max}		
40B1	8	9	9.52	11	12	12.7	14	-	-	-	-	40	63	80	4	M4x12	34	40	
45A	8	9	9.52	11	12	12.7	-	-	-	-	-	45	63	80	4	M4x12	34	40	
50B1	8	9	9.52	11	12	12.7	14	-	-	-	-	50	65	80	4	M5x16	34	40	
50BH1	8	9	9.52	11	12	12.7	14	-	-	-	-	50	65	80	4	5.5	34	40	
50C1	8	9	9.52	11	12	12.7	14	-	-	-	-	50	70	80	4	M4x10	34	40	
50D	8	9	9.52	11	12	12.7	14	-	-	-	-	50	95	80	4	M6x20	34	40	
55A	8	9	9.52	11	12	12.7	14	15.875	16	17	19	19.05	55.5	125.7	105	4	M6x20	34	40
60A2	8	9	9.52	11	12	12.7	14	-	-	-	-	60	75	80	4	M5x16	34	40	
60AH2	8	9	9.52	11	12	12.7	14	-	-	-	-	60	75	90	4	6.5	34	40	
60B1	8	9	9.52	11	12	12.7	14	15.875	16	-	-	60	85	80	4	M5x16	34	40	
60C1	8	9	9.52	11	12	12.7	14	15.875	16	-	-	60	90	80	4	M5x16	34	40	
70A1	8	9	9.52	11	12	12.7	14	15.875	16	17	19	19.05	70	85	80	4	M6x20	34	40
70AH1	8	9	9.52	11	12	12.7	14	15.875	16	17	19	19.05	70	85	90	4	6.5	34	40
70B1	8	9	9.52	11	12	12.7	14	15.875	16	17	19	19.05	70	90	80	4	M5x16	34	40
73A1	8	9	9.52	11	12	12.7	14	-	-	-	-	73	98.4	85	4	M5x16	34	40	
80A1	8	9	9.52	11	12	12.7	14	15.875	16	17	19	19.05	80	100	90	4	M6x16	34	40
95A	8	9	9.52	11	12	12.7	14	15.875	16	17	19	19.05	95	115	100	4	M8x20	34	40
95B	8	9	9.52	11	12	12.7	14	15.875	16	17	19	19.05	95	130	115	4	M8x20	34	40
110A	8	9	9.52	11	12	12.7	14	15.875	16	17	19	19.05	110	130	115	4	M8x20	34	40
110B	8	9	9.52	11	12	12.7	14	15.875	16	17	19	19.05	110	145	120	6.5	M8x20	44	50
110B1	8	9	9.52	11	12	12.7	14	15.875	16	17	19	19.05	110	145	120	6.5	M8x20	54	60

Für weitere Motoradapter und Antriebswellenbohrungen bitte nachfragen.

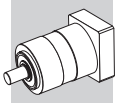

TR 080

FM

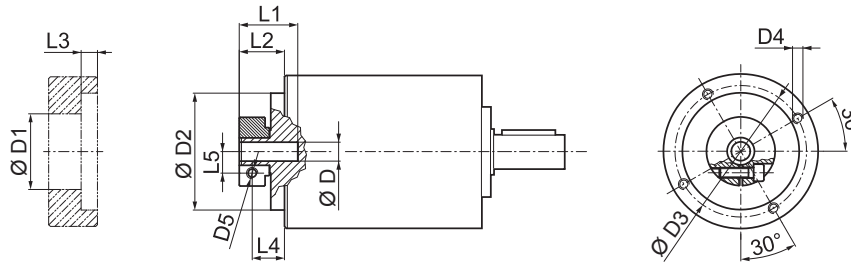

D				D1	D2	D3	D4	D5	L1	L2	L3	L4	L5
8	9	9.52		38	68	76.5	M6x12	M6	32.2	26.3	9.5	19.3	10.5
11	12	12.7		43	68	76.5	M6x12	M6	32.2	26.3	9.5	19.3	12.5
14	15.875	16	17	48	68	76.5	M6x12	M6	32.2	26.3	9.5	19.3	14.5
19	19.05			51	68	76.5	M6x12	M6	32.2	26.3	9.5	19.3	16.5

 i	M _{n2}	M _{a2}	M _{p2}	n ₁	n _{1 max}	φ _S	φ _R	C _t	R _{1 max}	R _{2 max}	A _{2 max}	η	J _G [kgcm ²]	
	[Nm]	[Nm]	[Nm]	[min ⁻¹]	[min ⁻¹]	[arcmin]	[arcmin]	[$\frac{Nm}{arcmin}$]	[N]	[N]	[N]	%	D	8 ... 12.7
TR 080 1_3	40	80	180	2900	3500	5'	3'	8.0	400	2500	3000	97	0.50	0.59
TR 080 1_4	50	80	200	3100	4500	5'	3'	8.0	400	2500	3000	97	0.34	0.43
TR 080 1_5	50	80	200	3200	4500	5'	3'	8.0	400	2500	3000	97	0.28	0.37
TR 080 1_6	50	80	200	3200	4500	5'	3'	8.0	400	2500	3000	97	0.21	0.30
TR 080 1_7	50	80	200	4000	6000	5'	3'	8.0	400	2500	3000	97	0.23	0.32
TR 080 1_10	40	80	180	4000	6000	5'	3'	8.0	400	2500	3000	97	0.20	0.29
TR 080 2_9	40	80	180	2900	3500	5'	3'	6.5	400	2500	3000	94	0.49	0.58
TR 080 2_12	70	100	250	2900	3500	5'	3'	6.5	400	2500	3000	94	0.47	0.56
TR 080 2_15	70	100	250	2900	3500	5'	3'	6.5	400	2500	3000	94	0.46	0.55
TR 080 2_16	70	100	250	3100	4500	5'	3'	6.5	400	2500	3000	94	0.32	0.41
TR 080 2_20	70	100	250	3200	4500	5'	3'	6.5	400	2500	3000	94	0.27	0.36
TR 080 2_25	70	100	250	3200	4500	5'	3'	6.5	400	2500	3000	94	0.27	0.36
TR 080 2_28	70	100	250	4000	6000	5'	3'	6.5	400	2500	3000	94	0.22	0.31
TR 080 2_30	40	80	180	4000	6000	5'	3'	6.5	400	2500	3000	94	0.20	0.29
TR 080 2_35	70	100	250	4000	6000	5'	3'	6.5	400	2500	3000	94	0.22	0.31
TR 080 2_36	50	80	200	3200	4500	5'	3'	6.5	400	2500	3000	94	0.20	0.29
TR 080 2_40	70	100	250	4000	6000	5'	3'	6.5	400	2500	3000	94	0.20	0.29
TR 080 2_50	70	100	250	4000	6000	5'	3'	6.5	400	2500	3000	94	0.19	0.28
TR 080 2_70	70	100	250	4000	6000	5'	3'	6.5	400	2500	3000	94	0.19	0.28
TR 080 2_100	40	80	180	4000	6000	5'	3'	6.5	400	2500	3000	94	0.19	0.28
TR 080 3_48	70	100	250	3100	4500	7'	5'	5.5	400	2500	3000	91	0.33	0.42
TR 080 3_64	70	100	250	3100	4500	7'	5'	5.5	400	2500	3000	91	0.32	0.41
TR 080 3_75	70	100	250	3200	4500	7'	5'	5.5	400	2500	3000	91	0.27	0.36
TR 080 3_80	70	100	250	3100	4500	7'	5'	5.5	400	2500	3000	91	0.32	0.41
TR 080 3_84	70	100	250	4000	6000	7'	5'	5.5	400	2500	3000	91	0.23	0.32
TR 080 3_90	40	80	180	4000	6000	7'	5'	5.5	400	2500	3000	91	0.20	0.29
TR 080 3_120	70	100	250	4000	6000	7'	5'	5.5	400	2500	3000	91	0.20	0.29
TR 080 3_125	70	100	250	3200	4500	7'	5'	5.5	400	2500	3000	91	0.27	0.36
TR 080 3_140	70	100	250	4000	6000	7'	5'	5.5	400	2500	3000	91	0.22	0.31
TR 080 3_150	70	100	250	4000	6000	7'	5'	5.5	400	2500	3000	91	0.20	0.29
TR 080 3_160	70	100	250	4000	6000	7'	5'	5.5	400	2500	3000	91	0.20	0.29
TR 080 3_175	70	100	250	4000	6000	7'	5'	5.5	400	2500	3000	91	0.22	0.31
TR 080 3_200	70	100	250	4000	6000	7'	5'	5.5	400	2500	3000	91	0.20	0.29
TR 080 3_210	70	100	250	4000	6000	7'	5'	5.5	400	2500	3000	91	0.20	0.29
TR 080 3_216	70	100	250	3200	4500	7'	5'	5.5	400	2500	3000	91	0.20	0.29
TR 080 3_250	70	100	250	4000	6000	7'	5'	5.5	400	2500	3000	91	0.19	0.28
TR 080 3_280	70	100	250	4000	6000	7'	5'	5.5	400	2500	3000	91	0.19	0.28
TR 080 3_350	70	100	250	4000	6000	7'	5'	5.5	400	2500	3000	91	0.19	0.28
TR 080 3_400	70	100	250	4000	6000	7'	5'	5.5	400	2500	3000	91	0.19	0.28
TR 080 3_500	70	100	250	4000	6000	7'	5'	5.5	400	2500	3000	91	0.19	0.28
TR 080 3_700	70	100	250	4000	6000	7'	5'	5.5	400	2500	3000	91	0.19	0.28
TR 080 3_1000	40	80	180	4000	6000	7'	5'	5.5	400	2500	3000	91	0.19	0.28

TR



TR G 080

40B1 ... 110B1

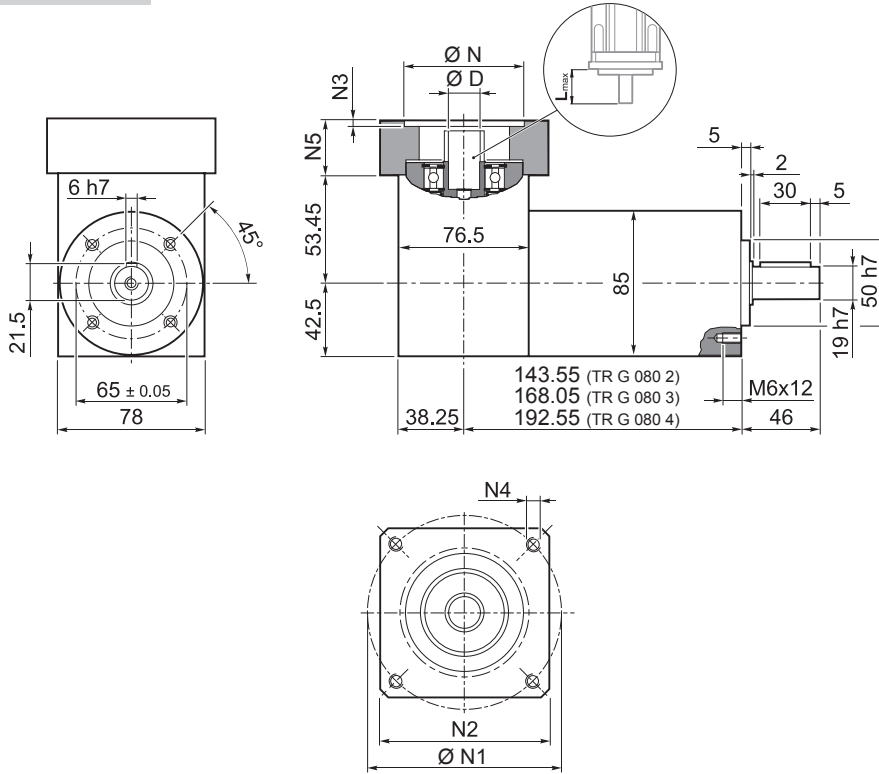

TR G 080 2	5.2
TR G 080 3	5.8
TR G 080 4	6.4

TR

											N	N1	N2	N3	N4	N5	Lmax		
40B1	8	9	9.52	11	12	12.7	14	-	-	-	-	40	63	80	4	M4x12	34	40	
45A	8	9	9.52	11	12	12.7	-	-	-	-	-	45	63	80	4	M4x12	34	40	
50B1	8	9	9.52	11	12	12.7	14	-	-	-	-	50	65	80	4	M5x16	34	40	
50BH1	8	9	9.52	11	12	12.7	14	-	-	-	-	50	65	80	4	5.5	34	40	
50C1	8	9	9.52	11	12	12.7	14	-	-	-	-	50	70	80	4	M4x10	34	40	
50D	8	9	9.52	11	12	12.7	14	-	-	-	-	50	95	80	4	M6x20	34	40	
55A	8	9	9.52	11	12	12.7	14	15.875	16	17	19	19.05	55.5	125.7	105	4	M6x20	34	40
60A2	8	9	9.52	11	12	12.7	14	-	-	-	-	60	75	80	4	M5x16	34	40	
60AH2	8	9	9.52	11	12	12.7	14	-	-	-	-	60	75	90	4	6.5	34	40	
60B1	8	9	9.52	11	12	12.7	14	15.875	16	-	-	60	85	80	4	M5x16	34	40	
60C1	8	9	9.52	11	12	12.7	14	15.875	16	-	-	60	90	80	4	M5x16	34	40	
70A1	8	9	9.52	11	12	12.7	14	15.875	16	17	19	19.05	70	85	80	4	M6x20	34	40
70AH1	8	9	9.52	11	12	12.7	14	15.875	16	17	19	19.05	70	85	90	4	6.5	34	40
70B1	8	9	9.52	11	12	12.7	14	15.875	16	17	19	19.05	70	90	80	4	M5x16	34	40
73A1	8	9	9.52	11	12	12.7	14	-	-	-	-	73	98.4	85	4	M5x16	34	40	
80A1	8	9	9.52	11	12	12.7	14	15.875	16	17	19	19.05	80	100	90	4	M6x16	34	40
95A	8	9	9.52	11	12	12.7	14	15.875	16	17	19	19.05	95	115	100	4	M8x20	34	40
95B	8	9	9.52	11	12	12.7	14	15.875	16	17	19	19.05	95	130	115	4	M8x20	34	40
110A	8	9	9.52	11	12	12.7	14	15.875	16	17	19	19.05	110	130	115	4	M8x20	34	40
110B	8	9	9.52	11	12	12.7	14	15.875	16	17	19	19.05	110	145	120	6.5	M8x20	44	50
110B1	8	9	9.52	11	12	12.7	14	15.875	16	17	19	19.05	110	145	120	6.5	M8x20	54	60

Für weitere Motoradapter und Antriebswellenbohrungen bitte nachfragen.

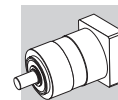

TR G 080

FM

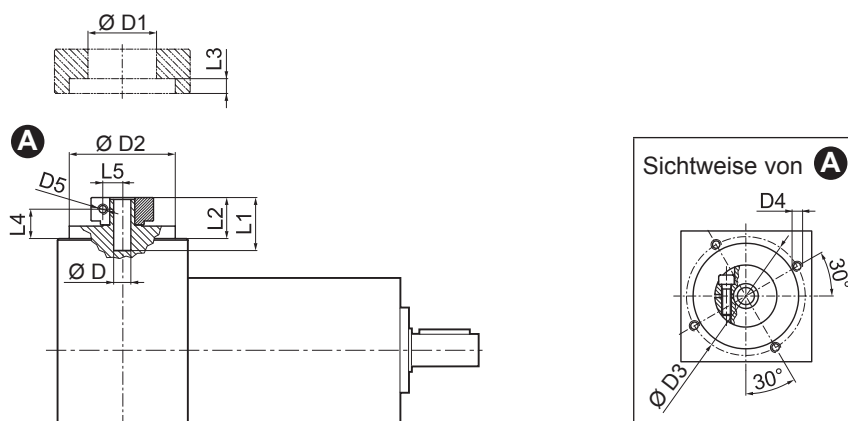

D			D1	D2	D3	D4	D5	L1	L2	L3	L4	L5
8	9	9.52	38	68	76.5	M6x12	M6	32.2	26.3	9.5	19.3	10.5
11	12	12.7	43	68	76.5	M6x12	M6	32.2	26.3	9.5	19.3	12.5
14	15.875	16	48	68	76.5	M6x12	M6	32.2	26.3	9.5	19.3	14.5
19	19.05		51	68	76.5	M6x12	M6	32.2	26.3	9.5	19.3	16.5

 i	M _{n 2}	M _{a 2}	M _{p 2}	n ₁	n _{1 max}	φ _S	φ _R	C _t	R _{2 max}	A _{2 max}	η	J _G [kgcm ²]	
	[Nm]	[Nm]	[Nm]	[min ⁻¹]	[min ⁻¹]	[arcmin]		$\frac{Nm}{arcmin}$	[N]	[N]	%	8 ... 12.7	14 ... 19.05
TR G 080 2_3	40	80	180	2900	3500	5'	3'	8.0	2500	3000	94	0.67	0.79
TR G 080 2_4	50	80	200	3100	4500	5'	3'	8.0	2500	3000	94	0.62	0.75
TR G 080 2_5	50	80	200	3200	4500	5'	3'	8.0	2500	3000	94	0.61	0.74
TR G 080 2_6	50	80	200	3200	4500	5'	3'	8.0	2500	3000	94	0.58	0.71
TR G 080 2_7	50	80	200	4000	6000	5'	3'	8.0	2500	3000	94	0.60	0.73
TR G 080 2_10	40	80	180	4000	6000	5'	3'	8.0	2500	3000	94	0.60	0.72
TR G 080 3_9	40	80	180	2900	3500	5'	3'	6.5	2500	3000	91	0.66	0.78
TR G 080 3_12	70	100	250	2900	3500	5'	3'	6.5	2500	3000	91	0.75	0.87
TR G 080 3_15	70	100	250	2900	3500	5'	3'	6.5	2500	3000	91	0.74	0.87
TR G 080 3_16	70	100	250	3100	4500	5'	3'	6.5	2500	3000	91	0.60	0.73
TR G 080 3_20	70	100	250	3200	4500	5'	3'	6.5	2500	3000	91	0.60	0.73
TR G 080 3_25	70	100	250	3200	4500	5'	3'	6.5	2500	3000	91	0.64	0.76
TR G 080 3_28	70	100	250	4000	6000	5'	3'	6.5	2500	3000	91	0.59	0.72
TR G 080 3_30	40	80	180	4000	6000	5'	3'	6.5	2500	3000	91	0.60	0.72
TR G 080 3_35	70	100	250	4000	6000	5'	3'	6.5	2500	3000	91	0.61	0.74
TR G 080 3_36	50	80	200	3200	4500	5'	3'	6.5	2500	3000	91	0.57	0.70
TR G 080 3_40	70	100	250	4000	6000	5'	3'	6.5	2500	3000	91	0.60	0.72
TR G 080 3_50	70	100	250	4000	6000	5'	3'	6.5	2500	3000	91	0.59	0.71
TR G 080 3_70	70	100	250	4000	6000	5'	3'	6.5	2500	3000	91	0.59	0.71
TR G 080 3_100	40	80	180	4000	6000	5'	3'	6.5	2500	3000	91	0.59	0.71
TR G 080 4_48	70	100	250	3100	4500	7'	5'	5.5	2500	3000	89	0.61	0.75
TR G 080 4_64	70	100	250	3100	4500	7'	5'	5.5	2500	3000	89	0.60	0.73
TR G 080 4_75	70	100	250	3200	4500	7'	5'	5.5	2500	3000	89	0.60	0.73
TR G 080 4_80	70	100	250	3100	4500	7'	5'	5.5	2500	3000	89	0.60	0.73
TR G 080 4_84	70	100	250	4000	6000	7'	5'	5.5	2500	3000	89	0.60	0.73
TR G 080 4_90	40	80	180	4000	6000	7'	5'	5.5	2500	3000	89	0.60	0.72
TR G 080 4_120	70	100	250	4000	6000	7'	5'	5.5	2500	3000	89	0.60	0.72
TR G 080 4_125	70	100	250	3200	4500	7'	5'	5.5	2500	3000	89	0.60	0.73
TR G 080 4_140	70	100	250	4000	6000	7'	5'	5.5	2500	3000	89	0.59	0.72
TR G 080 4_150	70	100	250	4000	6000	7'	5'	5.5	2500	3000	89	0.60	0.72
TR G 080 4_160	70	100	250	4000	6000	7'	5'	5.5	2500	3000	89	0.60	0.72
TR G 080 4_175	70	100	250	4000	6000	7'	5'	5.5	2500	3000	89	0.59	0.72
TR G 080 4_200	70	100	250	4000	6000	7'	5'	5.5	2500	3000	89	0.60	0.72
TR G 080 4_210	70	100	250	4000	6000	7'	5'	5.5	2500	3000	89	0.60	0.72
TR G 080 4_216	70	100	250	3200	4500	7'	5'	5.5	2500	3000	89	0.57	0.70
TR G 080 4_250	70	100	250	4000	6000	7'	5'	5.5	2500	3000	89	0.59	0.71
TR G 080 4_280	70	100	250	4000	6000	7'	5'	5.5	2500	3000	89	0.59	0.71
TR G 080 4_350	70	100	250	4000	6000	7'	5'	5.5	2500	3000	89	0.59	0.71
TR G 080 4_400	70	100	250	4000	6000	7'	5'	5.5	2500	3000	89	0.59	0.71
TR G 080 4_500	70	100	250	4000	6000	7'	5'	5.5	2500	3000	89	0.59	0.71
TR G 080 4_700	70	100	250	4000	6000	7'	5'	5.5	2500	3000	89	0.59	0.71
TR G 080 4_1000	40	80	180	4000	6000	7'	5'	5.5	2500	3000	89	0.59	0.71

TR





TR MB 080

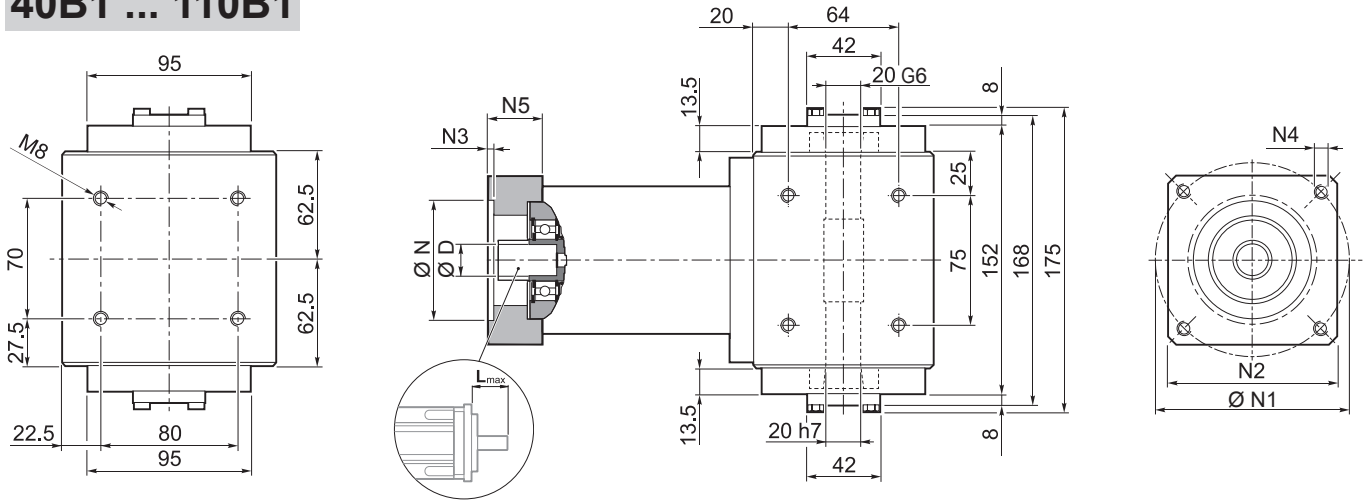

40B1 ... 110B1

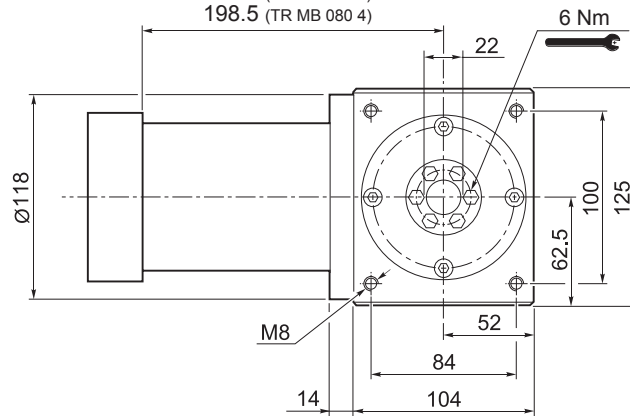

149.5 (TR MB 080 2)
174 (TR MB 080 3)
198.5 (TR MB 080 4)



	
TR MB 080 2	14.0
TR MB 080 3	15.0
TR MB 080 4	16.0

												N	N1	N2	N3	N4	N5	L _{max}	
40B1	8	9	9.52	11	12	12.7	14	-	-	-	-	40	63	80	4	M4x12	34	40	
45A	8	9	9.52	11	12	12.7	-	-	-	-	-	45	63	80	4	M4x12	34	40	
50B1	8	9	9.52	11	12	12.7	14	-	-	-	-	50	65	80	4	M5x16	34	40	
50BH1	8	9	9.52	11	12	12.7	14	-	-	-	-	50	65	80	4	5.5	34	40	
50C1	8	9	9.52	11	12	12.7	14	-	-	-	-	50	70	80	4	M4x10	34	40	
50D	8	9	9.52	11	12	12.7	14	-	-	-	-	50	95	80	4	M6x20	34	40	
55A	8	9	9.52	11	12	12.7	14	15.875	16	17	19	19.05	55.5	125.7	105	4	M6x20	34	40
60A2	8	9	9.52	11	12	12.7	14	-	-	-	-	60	75	80	4	M5x16	34	40	
60AH2	8	9	9.52	11	12	12.7	14	-	-	-	-	60	75	90	4	6.5	34	40	
60B1	8	9	9.52	11	12	12.7	14	15.875	16	-	-	60	85	80	4	M5x16	34	40	
60C1	8	9	9.52	11	12	12.7	14	15.875	16	-	-	60	90	80	4	M5x16	34	40	
70A1	8	9	9.52	11	12	12.7	14	15.875	16	17	19	19.05	70	85	80	4	M6x20	34	40
70AH1	8	9	9.52	11	12	12.7	14	15.875	16	17	19	19.05	70	85	90	4	6.5	34	40
70B1	8	9	9.52	11	12	12.7	14	15.875	16	17	19	19.05	70	90	80	4	M5x16	34	40
73A1	8	9	9.52	11	12	12.7	14	-	-	-	-	73	98.4	85	4	M5x16	34	40	
80A1	8	9	9.52	11	12	12.7	14	15.875	16	17	19	19.05	80	100	90	4	M6x16	34	40
95A	8	9	9.52	11	12	12.7	14	15.875	16	17	19	19.05	95	115	100	4	M8x20	34	40
95B	8	9	9.52	11	12	12.7	14	15.875	16	17	19	19.05	95	130	115	4	M8x20	34	40
110A	8	9	9.52	11	12	12.7	14	15.875	16	17	19	19.05	110	130	115	4	M8x20	34	40
110B	8	9	9.52	11	12	12.7	14	15.875	16	17	19	19.05	110	145	120	6.5	M8x20	44	50
110B1	8	9	9.52	11	12	12.7	14	15.875	16	17	19	19.05	110	145	120	6.5	M8x20	54	60

Für weitere Motoradapter und Antriebswellenbohrungen bitte nachfragen.

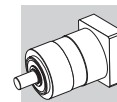

TR MB 080

FM

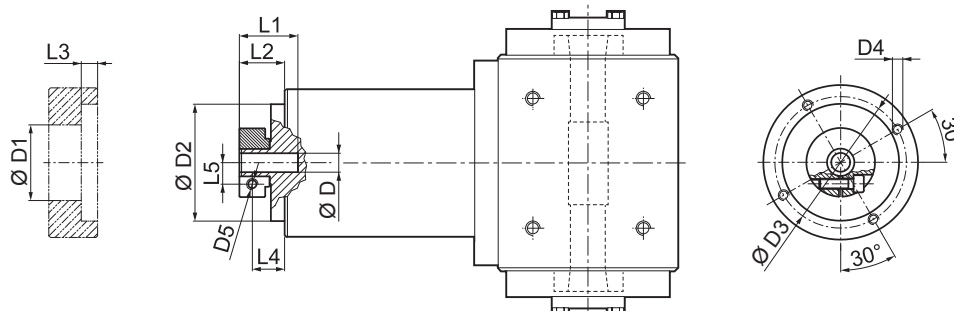

				D1	D2	D3	D4	D5	L1	L2	L3	L4	L5
8	9	9.52		38	68	76.5	M6x12	M6	32.2	26.3	9.5	19.3	10.5
11	12	12.7		43	68	76.5	M6x12	M6	32.2	26.3	9.5	19.3	12.5
14	15.875	16	17	48	68	76.5	M6x12	M6	32.2	26.3	9.5	19.3	14.5
19	19.05			51	68	76.5	M6x12	M6	32.2	26.3	9.5	19.3	16.5

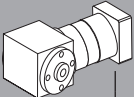
	i	M _{n2}	M _{a2}	M _{p2}	n ₁	n _{1 max}	φ _s	φ _R	C _t	η	J _G [kgcm ²]	
		[Nm]	[Nm]	[Nm]	[min ⁻¹]	[min ⁻¹]	[arcmin]	[Nm/arcmin]	%	8 ... 12.7	14 ... 19.05	
TR MB 080 2_3		40	80	180	2900	3500	5'	3'	8.0	94	0.50	0.59
TR MB 080 2_4		50	80	200	3100	4500	5'	3'	8.0	94	0.34	0.43
TR MB 080 2_5		50	80	200	3200	4500	5'	3'	8.0	94	0.28	0.37
TR MB 080 2_6		50	80	200	3200	4500	5'	3'	8.0	94	0.21	0.30
TR MB 080 2_7		50	80	200	4000	6000	5'	3'	8.0	94	0.23	0.32
TR MB 080 2_10		40	80	180	4000	6000	5'	3'	8.0	94	0.20	0.29
TR MB 080 3_9		40	80	180	2900	3500	5'	3'	6.5	91	0.49	0.58
TR MB 080 3_12		70	100	250	2900	3500	5'	3'	6.5	91	0.47	0.56
TR MB 080 3_15		70	100	250	2900	3500	5'	3'	6.5	91	0.46	0.55
TR MB 080 3_16		70	100	250	3100	4500	5'	3'	6.5	91	0.32	0.41
TR MB 080 3_20		70	100	250	3200	4500	5'	3'	6.5	91	0.27	0.36
TR MB 080 3_25		70	100	250	3200	4500	5'	3'	6.5	91	0.27	0.36
TR MB 080 3_28		70	100	250	4000	6000	5'	3'	6.5	91	0.22	0.31
TR MB 080 3_30		40	80	180	4000	6000	5'	3'	6.5	91	0.20	0.29
TR MB 080 3_35		70	100	250	4000	6000	5'	3'	6.5	91	0.22	0.31
TR MB 080 3_36		50	80	200	3200	4500	5'	3'	6.5	91	0.20	0.29
TR MB 080 3_40		70	100	250	4000	6000	5'	3'	6.5	91	0.20	0.29
TR MB 080 3_50		70	100	250	4000	6000	5'	3'	6.5	91	0.19	0.28
TR MB 080 3_70		70	100	250	4000	6000	5'	3'	6.5	91	0.19	0.28
TR MB 080 3_100		40	80	180	4000	6000	5'	3'	6.5	91	0.19	0.28
TR MB 080 4_48		70	100	250	3100	4500	7'	5'	5.5	89	0.33	0.42
TR MB 080 4_64		70	100	250	3100	4500	7'	5'	5.5	89	0.32	0.41
TR MB 080 4_75		70	100	250	3200	4500	7'	5'	5.5	89	0.27	0.36
TR MB 080 4_80		70	100	250	3100	4500	7'	5'	5.5	89	0.32	0.41
TR MB 080 4_84		70	100	250	4000	6000	7'	5'	5.5	89	0.23	0.32
TR MB 080 4_90		40	80	180	4000	6000	7'	5'	5.5	89	0.20	0.29
TR MB 080 4_120		70	100	250	4000	6000	7'	5'	5.5	89	0.20	0.29
TR MB 080 4_125		70	100	250	3200	4500	7'	5'	5.5	89	0.27	0.36
TR MB 080 4_140		70	100	250	4000	6000	7'	5'	5.5	89	0.22	0.31
TR MB 080 4_150		70	100	250	4000	6000	7'	5'	5.5	89	0.20	0.29
TR MB 080 4_160		70	100	250	4000	6000	7'	5'	5.5	89	0.20	0.29
TR MB 080 4_175		70	100	250	4000	6000	7'	5'	5.5	89	0.22	0.31
TR MB 080 4_200		70	100	250	4000	6000	7'	5'	5.5	89	0.20	0.29
TR MB 080 4_210		70	100	250	4000	6000	7'	5'	5.5	89	0.20	0.29
TR MB 080 4_216		70	100	250	3200	4500	7'	5'	5.5	89	0.20	0.29
TR MB 080 4_250		70	100	250	4000	6000	7'	5'	5.5	89	0.19	0.28
TR MB 080 4_280		70	100	250	4000	6000	7'	5'	5.5	89	0.19	0.28
TR MB 080 4_350		70	100	250	4000	6000	7'	5'	5.5	89	0.19	0.28
TR MB 080 4_400		70	100	250	4000	6000	7'	5'	5.5	89	0.19	0.28
TR MB 080 4_500		70	100	250	4000	6000	7'	5'	5.5	89	0.19	0.28
TR MB 080 4_700		70	100	250	4000	6000	7'	5'	5.5	89	0.19	0.28
TR MB 080 4_1000		40	80	180	4000	6000	7'	5'	5.5	89	0.19	0.28

TR

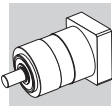

TR 105

IS

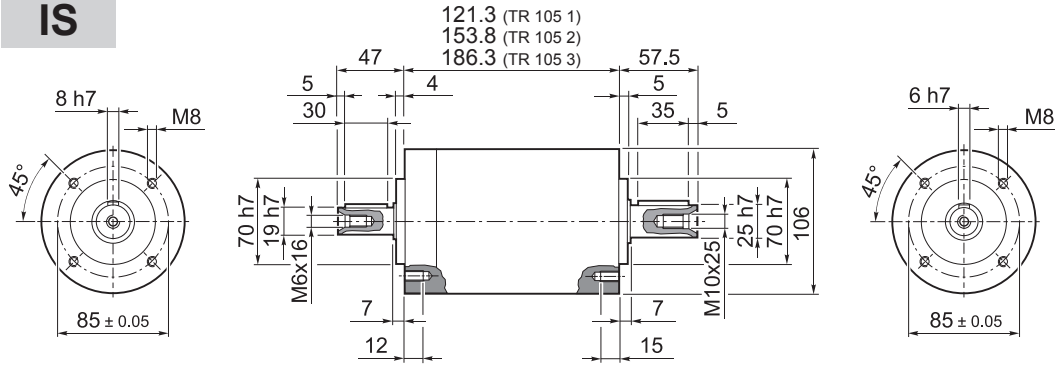

TR 105 1	6.5
TR 105 2	8.5
TR 105 3	10.5

TR

50D ... 130A1

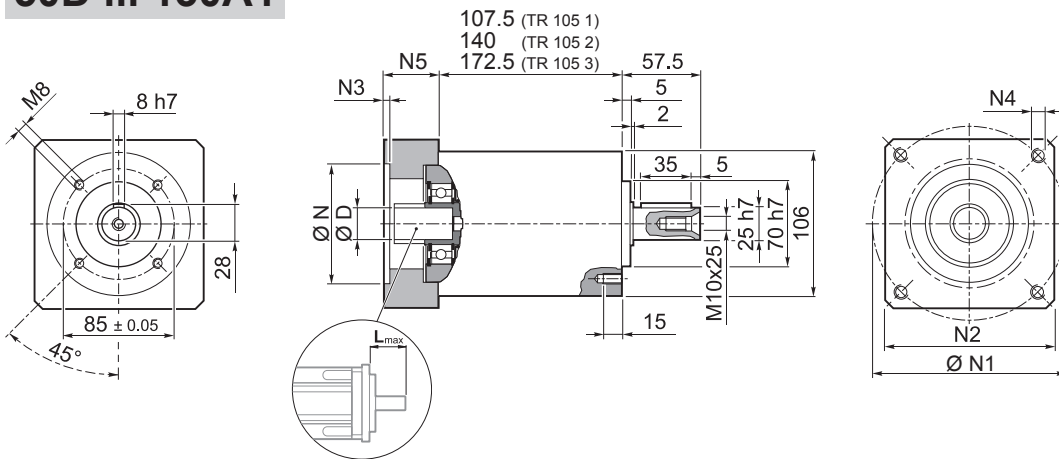

TR 105 1	6.5
TR 105 2	8.5
TR 105 3	10.5

											N	N1	N2	N3	N4	N5	L _{max}	
50D	11	12	12.7	14	15	15.875	16	19	-	-	-	50	95	100	5	M6x14	28	40
55A	11	12	12.7	14	15	15.875	16	19	-	-	-	55	125.7	105	5	M6x16	28	40
60A2	11	12	12.7	14	15	15.875	16	19	-	-	-	60	75	100	6.5	M5x14	28	40
60AH2	11	12	12.7	14	15	15.875	16	19	-	-	-	60	75	100	4	6.5	33	40
60B1	11	12	12.7	14	15	15.875	16	19	-	-	-	60	85	100	6.5	M5x14	28	40
70A1	11	12	12.7	14	15	15.875	16	19	-	-	-	70	85	100	6.5	M6x14	28	40
70AH1	11	12	12.7	14	15	15.875	16	19	-	-	-	70	85	100	4	6.5	33	40
70B1	11	12	12.7	14	15	15.875	16	19	-	-	-	70	90	100	6.5	M5x12	28	40
80A1	11	12	12.7	14	15	15.875	16	19	-	-	-	80	100	100	6.5	M6x16	28	40
80AH1	11	12	12.7	14	15	15.875	16	19	-	-	-	80	100	100	4	6.5	33	40
95A	11	12	12.7	14	15	15.875	16	19	-	-	-	95	115	100	6.5	M8x18	28	40
95A1	11	12	12.7	14	15	15.875	16	19	22	24	-	95	115	100	6.5	M8x18	38	50
95B	11	12	12.7	14	15	15.875	16	19	-	-	-	95	130	115	6.5	M8x18	28	40
110A	11	12	12.7	14	15	15.875	16	19	-	-	-	110	130	115	6.5	M8x18	28	40
110A1	11	12	12.7	14	15	15.875	16	19	22	24	-	110	130	115	6.5	M8x20	38	50
110B	11	12	12.7	14	15	15.875	16	19	22	24	-	110	145	120	6.5	M8x20	38	50
110B1	11	12	12.7	14	15	15.875	16	19	22	24	28	110	145	120	6.5	M8x20	48	60
130A	11	12	12.7	14	15	15.875	16	19	22	24	-	130	165	140	6.5	M10x20	38	50
130A1	11	12	12.7	14	15	15.875	16	19	22	24	28	130	165	140	6.5	M10x25	48	60

Für weitere Motoradapter und Antriebswellenbohrungen bitte nachfragen.

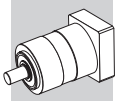

TR 105

FM

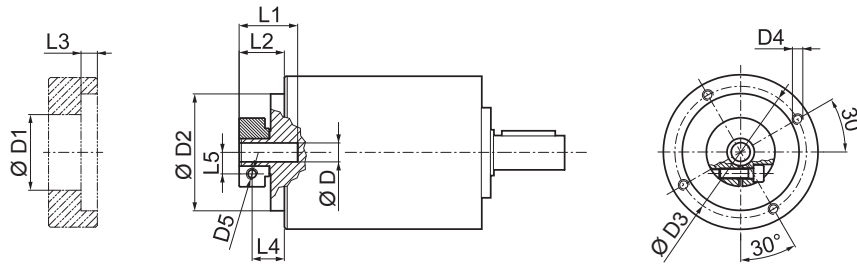

D				D1	D2	D3	D4	D5	L1	L2	L3	L4	L5
11	12	12.7		43	90	98	M6x15	M6	31.5	19.5	7.6	12	12.5
14	15	15.875	16	48	90	98	M6x15	M6	31.5	19.5	7.6	12	14.5
19				51	90	98	M6x15	M6	31.5	19.5	7.6	12	16.5
22	24			56.5	90	98	M6x15	M6	35	23	7.6	12	19
28				67	90	98	M6x15	M8	35	23	7.6	14	22.5
32				71	90	98	M6x15	M8	37	25	7.6	16	24.5

i	M _{n 2} [Nm]	M _{a 2} [Nm]	M _{p 2} [Nm]	n ₁ [min ⁻¹]	n _{1 max} [min ⁻¹]	φ _S [arcmin]	φ _R [arcmin]	C _t [Nm/arcmin]	R _{1 max} [N]	R _{2 max} [N]	A _{2 max} [N]	η ₁ %	J _G [kgcm ²]			
													D	11 ... 12.7	14 ... 19	22 - 24
TR 105 1_3	100	180	360	2500	3500	5'	3'	24.0	600	3800	4000	97	1.70	1.78	2.22	2.59
TR 105 1_4	140	210	450	2800	4500	5'	3'	24.0	600	3800	4000	97	0.99	1.06	1.51	1.87
TR 105 1_5	140	210	450	3000	4500	5'	3'	24.0	600	3800	4000	97	0.72	0.79	1.23	1.60
TR 105 1_6	140	210	450	3000	4500	5'	3'	24.0	600	3800	4000	97	0.36	0.43	0.88	1.24
TR 105 1_7	140	210	450	3500	5000	5'	3'	24.0	600	3800	4000	97	0.47	0.55	0.99	1.35
TR 105 1_10	100	180	360	3500	5000	5'	3'	24.0	600	3800	4000	97	0.33	0.41	0.85	1.21
TR 105 2_9	100	180	360	2500	3500	5'	3'	21.5	600	3800	4000	94	1.58	1.63	2.07	2.44
TR 105 2_12	170	250	600	2500	3500	5'	3'	21.5	600	3800	4000	94	1.52	1.59	2.03	2.40
TR 105 2_15	170	250	600	2500	3500	5'	3'	21.5	600	3800	4000	94	1.47	1.55	1.99	2.36
TR 105 2_16	170	250	600	2800	4500	5'	3'	21.5	600	3800	4000	94	0.87	0.95	1.39	1.76
TR 105 2_20	170	250	600	3000	4500	5'	3'	21.5	600	3800	4000	94	0.86	0.93	1.37	1.74
TR 105 2_25	170	250	600	3000	4500	5'	3'	21.5	600	3800	4000	94	0.63	0.71	1.15	1.51
TR 105 2_28	170	250	600	3500	5000	5'	3'	21.5	600	3800	4000	94	0.43	0.51	0.95	1.32
TR 105 2_30	100	180	360	3500	5000	5'	3'	21.5	600	3800	4000	94	0.32	0.40	0.84	1.20
TR 105 2_35	170	250	600	3500	5000	5'	3'	21.5	600	3800	4000	94	0.43	0.50	0.95	1.31
TR 105 2_36	140	210	450	3000	4500	5'	3'	21.5	600	3800	4000	94	0.32	0.39	0.84	1.20
TR 105 2_40	170	250	600	3500	5000	5'	3'	21.5	600	3800	4000	94	0.31	0.39	0.83	1.20
TR 105 2_50	170	250	600	3500	5000	5'	3'	21.5	600	3800	4000	94	0.31	0.39	0.83	1.19
TR 105 2_70	170	250	600	3500	5000	5'	3'	21.5	600	3800	4000	94	0.31	0.38	0.83	1.19
TR 105 2_100	100	180	360	3500	5000	5'	3'	21.5	600	3800	4000	94	0.31	0.38	0.83	1.19
TR 105 3_48	170	250	600	2800	4500	7'	5'	18.0	600	3800	4000	91	0.91	0.98	1.42	1.79
TR 105 3_64	170	250	600	2800	4500	7'	5'	18.0	600	3800	4000	91	0.87	0.94	1.38	1.75
TR 105 3_75	170	250	600	3000	4500	7'	5'	18.0	600	3800	4000	91	0.66	0.74	1.18	1.55
TR 105 3_80	170	250	600	2800	4500	7'	5'	18.0	600	3800	4000	91	0.86	0.94	1.38	1.75
TR 105 3_84	170	250	600	3500	5000	7'	5'	18.0	600	3800	4000	91	0.44	0.52	0.96	1.33
TR 105 3_90	100	180	360	3500	5000	7'	5'	18.0	600	3800	4000	91	0.32	0.39	0.84	1.20
TR 105 3_120	170	250	600	3500	5000	7'	5'	18.0	600	3800	4000	91	0.32	0.39	0.84	1.20
TR 105 3_125	170	250	600	3000	4500	7'	5'	18.0	600	3800	4000	91	0.63	0.70	1.15	1.51
TR 105 3_140	170	250	600	3500	5000	7'	5'	18.0	600	3800	4000	91	0.43	0.51	0.95	1.32
TR 105 3_150	170	250	600	3500	5000	7'	5'	18.0	600	3800	4000	91	0.32	0.39	0.84	1.20
TR 105 3_160	170	250	600	3500	5000	7'	5'	18.0	600	3800	4000	91	0.31	0.39	0.83	1.21
TR 105 3_175	170	250	600	3500	5000	7'	5'	18.0	600	3800	4000	91	0.43	0.50	0.95	1.31
TR 105 3_200	170	250	600	3500	5000	7'	5'	18.0	600	3800	4000	91	0.31	0.39	0.83	1.20
TR 105 3_210	170	250	600	3500	5000	7'	5'	18.0	600	3800	4000	91	0.32	0.39	0.84	1.20
TR 105 3_216	170	250	600	3000	4500	7'	5'	18.0	600	3800	4000	91	0.31	0.39	0.83	1.20
TR 105 3_250	170	250	600	3500	5000	7'	5'	18.0	600	3800	4000	91	0.31	0.39	0.83	1.19
TR 105 3_280	170	250	600	3500	5000	7'	5'	18.0	600	3800	4000	91	0.31	0.38	0.83	1.19
TR 105 3_350	170	250	600	3500	5000	7'	5'	18.0	600	3800	4000	91	0.31	0.38	0.83	1.19
TR 105 3_400	170	250	600	3500	5000	7'	5'	18.0	600	3800	4000	91	0.31	0.38	0.83	1.19
TR 105 3_500	170	250	600	3500	5000	7'	5'	18.0	600	3800	4000	91	0.31	0.38	0.83	1.19
TR 105 3_700	170	250	600	3500	5000	7'	5'	18.0	600	3800	4000	91	0.31	0.38	0.83	1.19
TR 105 3_1000	100	180	360	3500	5000	7'	5'	18.0	600	3800	4000	91	0.31	0.38	0.83	1.19

TR



TR G 105

50D ... 130A1

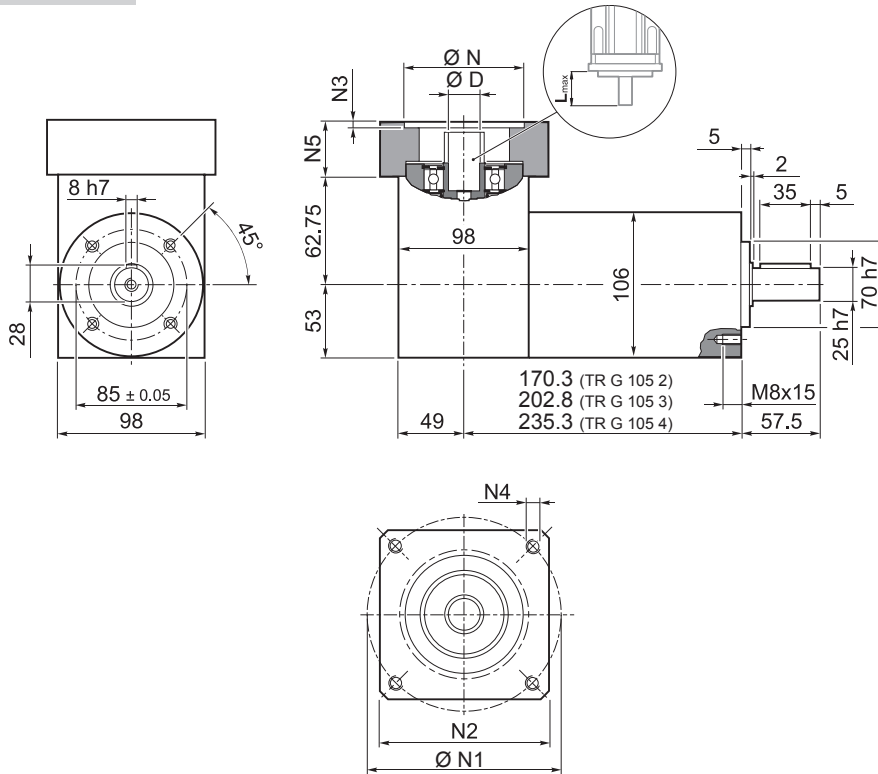

TR

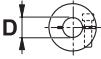
												N	N1	N2	N3	N4	N5	L _{max}	
	D	N1	N2	N3	N4	N5													
50D	11	12	12.7	14	15	15.875	16	19	-	-	-	-	50	95	100	5	M6x14	28	40
55A	11	12	12.7	14	15	15.875	16	19	-	-	-	-	55	125.7	105	5	M6x16	28	40
60A2	11	12	12.7	14	15	15.875	16	19	-	-	-	-	60	75	100	6.5	M5x14	28	40
60AH2	11	12	12.7	14	15	15.875	16	19	-	-	-	-	60	75	100	4	6.5	33	40
60B1	11	12	12.7	14	15	15.875	16	19	-	-	-	-	60	85	100	6.5	M5x14	28	40
70A1	11	12	12.7	14	15	15.875	16	19	-	-	-	-	70	85	100	6.5	M6x14	28	40
70AH1	11	12	12.7	14	15	15.875	16	19	-	-	-	-	70	85	100	4	6.5	33	40
70B1	11	12	12.7	14	15	15.875	16	19	-	-	-	-	70	90	100	6.5	M5x12	28	40
80A1	11	12	12.7	14	15	15.875	16	19	-	-	-	-	80	100	100	6.5	M6x16	28	40
80AH1	11	12	12.7	14	15	15.875	16	19	-	-	-	-	80	100	100	4	6.5	33	40
95A	11	12	12.7	14	15	15.875	16	19	-	-	-	-	95	115	100	6.5	M8x18	28	40
95A1	11	12	12.7	14	15	15.875	16	19	22	24	-	-	95	115	100	6.5	M8x18	38	50
95B	11	12	12.7	14	15	15.875	16	19	-	-	-	-	95	130	115	6.5	M8x18	28	40
110A	11	12	12.7	14	15	15.875	16	19	-	-	-	-	110	130	115	6.5	M8x18	28	40
110A1	11	12	12.7	14	15	15.875	16	19	22	24	-	-	110	130	115	6.5	M8x20	38	50
110B	11	12	12.7	14	15	15.875	16	19	22	24	-	-	110	145	120	6.5	M8x20	38	50
110B1	11	12	12.7	14	15	15.875	16	19	22	24	28	-	110	145	120	6.5	M8x20	48	60
130A	11	12	12.7	14	15	15.875	16	19	22	24	-	-	130	165	140	6.5	M10x20	38	50
130A1	11	12	12.7	14	15	15.875	16	19	22	24	28	32	130	165	140	6.5	M10x25	48	60

Für weitere Motoradapter und Antriebswellenbohrungen bitte nachfragen.

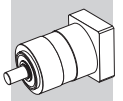

TR G 105

FM

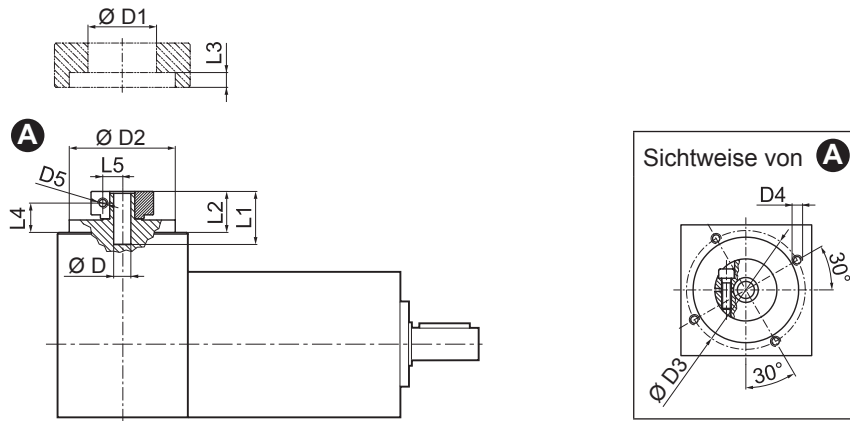

D				D1	D2	D3	D4	D5	L1	L2	L3	L4	L5
11	12	12.7		43	90	98	M6x15	M6	31.5	19.5	7.6	12	12.5
14	15	15.875	16	48	90	98	M6x15	M6	31.5	19.5	7.6	12	14.5
19				51	90	98	M6x15	M6	31.5	19.5	7.6	12	16.5
22	24			56.5	90	98	M6x15	M6	35	23	7.6	12	19
28				67	90	98	M6x15	M8	35	23	7.6	14	22.5
32				71	90	98	M6x15	M8	37	25	7.6	16	24.5

i	M _{n 2} [Nm]	M _{a 2} [Nm]	M _{p 2} [Nm]	n ₁ [min ⁻¹]	n _{1 max} [min ⁻¹]	φ _S [arcmin]	φ _R [arcmin]	C _t [Nm/arcmin]	R _{2 max} [N]	A _{2 max} [N]	η %	J _G [kgcm ²]			
												D			
												11 ... 12.7	14 ... 19	22 - 24	28 - 32
TR G 105 2_3	100	180	360	2500	3500	5'	3'	24.0	3800	4000	94	1.85	2.01	2.33	3.07
TR G 105 2_4	140	210	450	2800	4500	5'	3'	24.0	3800	4000	94	1.14	1.29	1.62	2.35
TR G 105 2_5	140	210	450	3000	4500	5'	3'	24.0	3800	4000	94	1.07	1.21	1.34	2.08
TR G 105 2_6	140	210	450	3000	4500	5'	3'	24.0	3800	4000	94	0.87	1.02	1.16	1.89
TR G 105 2_7	140	210	450	3500	5000	5'	3'	24.0	3800	4000	94	0.98	1.14	1.27	2.00
TR G 105 2_10	100	180	360	3500	5000	5'	3'	24.0	3800	4000	94	0.94	1.09	1.23	1.95
TR G 105 3_9	100	180	360	2500	3500	5'	3'	21.5	3800	4000	91	1.76	1.86	2.18	2.92
TR G 105 3_12	170	250	600	2500	3500	5'	3'	21.5	3800	4000	91	1.60	1.75	2.14	2.88
TR G 105 3_15	170	250	600	2500	3500	5'	3'	21.5	3800	4000	91	1.57	1.73	2.10	2.84
TR G 105 3_16	170	250	600	2800	4500	5'	3'	21.5	3800	4000	91	1.02	1.18	1.50	2.24
TR G 105 3_20	170	250	600	3000	4500	5'	3'	21.5	3800	4000	91	1.20	1.35	1.48	2.22
TR G 105 3_25	170	250	600	3000	4500	5'	3'	21.5	3800	4000	91	1.13	1.29	1.42	2.15
TR G 105 3_28	170	250	600	3500	5000	5'	3'	21.5	3800	4000	91	0.94	1.10	1.23	1.97
TR G 105 3_30	100	180	360	3500	5000	5'	3'	21.5	3800	4000	91	0.93	1.08	1.22	1.94
TR G 105 3_35	170	250	600	3500	5000	5'	3'	21.5	3800	4000	91	1.02	1.17	1.31	2.04
TR G 105 3_36	140	210	450	3000	4500	5'	3'	21.5	3800	4000	91	0.83	0.98	1.12	1.85
TR G 105 3_40	170	250	600	3500	5000	5'	3'	21.5	3800	4000	91	0.96	1.11	1.25	1.98
TR G 105 3_50	170	250	600	3500	5000	5'	3'	21.5	3800	4000	91	0.96	1.11	1.25	1.98
TR G 105 3_70	170	250	600	3500	5000	5'	3'	21.5	3800	4000	91	0.92	1.06	1.21	1.93
TR G 105 3_100	100	180	360	3500	5000	5'	3'	21.5	3800	4000	91	0.92	1.06	1.21	1.93
TR G 105 4_48	170	250	600	2800	4500	7'	5'	18.0	3800	4000	89	1.06	1.21	1.53	2.27
TR G 105 4_64	170	250	600	2800	4500	7'	5'	18.0	3800	4000	89	1.02	1.17	1.49	2.23
TR G 105 4_75	170	250	600	3000	4500	7'	5'	18.0	3800	4000	89	1.00	1.16	1.29	2.03
TR G 105 4_80	170	250	600	2800	4500	7'	5'	18.0	3800	4000	89	1.01	1.17	1.49	2.23
TR G 105 4_84	170	250	600	3500	5000	7'	5'	18.0	3800	4000	89	0.95	1.11	1.24	1.98
TR G 105 4_90	100	180	360	3500	5000	7'	5'	18.0	3800	4000	89	0.93	1.07	1.22	1.94
TR G 105 4_120	170	250	600	3500	5000	7'	5'	18.0	3800	4000	89	0.93	1.07	1.22	1.94
TR G 105 4_125	170	250	600	3000	4500	7'	5'	18.0	3800	4000	89	0.97	1.12	1.26	1.99
TR G 105 4_140	170	250	600	3500	5000	7'	5'	18.0	3800	4000	89	0.94	1.10	1.23	1.97
TR G 105 4_150	170	250	600	3500	5000	7'	5'	18.0	3800	4000	89	0.93	1.07	1.22	1.94
TR G 105 4_160	170	250	600	3500	5000	7'	5'	18.0	3800	4000	89	0.92	1.07	1.21	1.96
TR G 105 4_175	170	250	600	3500	5000	7'	5'	18.0	3800	4000	89	0.94	1.09	1.23	1.96
TR G 105 4_200	170	250	600	3500	5000	7'	5'	18.0	3800	4000	89	0.92	1.07	1.21	1.94
TR G 105 4_210	170	250	600	3500	5000	7'	5'	18.0	3800	4000	89	0.93	1.07	1.22	1.94
TR G 105 4_216	170	250	600	3000	4500	7'	5'	18.0	3800	4000	89	0.83	0.98	1.11	1.85
TR G 105 4_250	170	250	600	3500	5000	7'	5'	18.0	3800	4000	89	0.92	1.07	1.21	1.93
TR G 105 4_280	170	250	600	3500	5000	7'	5'	18.0	3800	4000	89	0.92	1.06	1.21	1.93
TR G 105 4_350	170	250	600	3500	5000	7'	5'	18.0	3800	4000	89	0.92	1.06	1.21	1.93
TR G 105 4_400	170	250	600	3500	5000	7'	5'	18.0	3800	4000	89	0.92	1.06	1.21	1.93
TR G 105 4_500	170	250	600	3500	5000	7'	5'	18.0	3800	4000	89	0.92	1.06	1.21	1.93
TR G 105 4_700	170	250	600	3500	5000	7'	5'	18.0	3800	4000	89	0.92	1.06	1.21	1.93
TR G 105 4_1000	100	180	360	3500	5000	7'	5'	18.0	3800	4000	89	0.92	1.06	1.21	1.93

TR



TR MB 105

50D ... 130A1

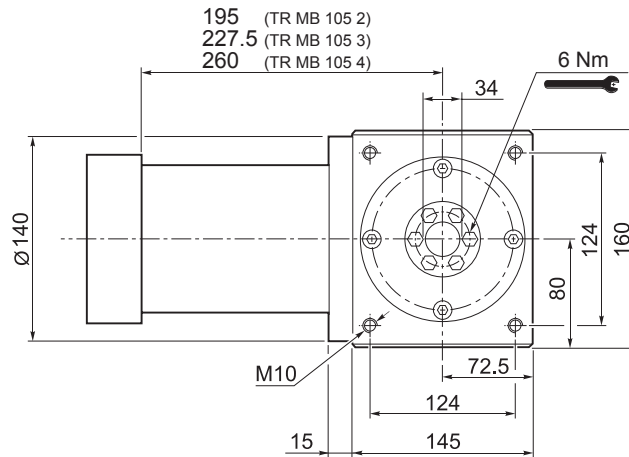
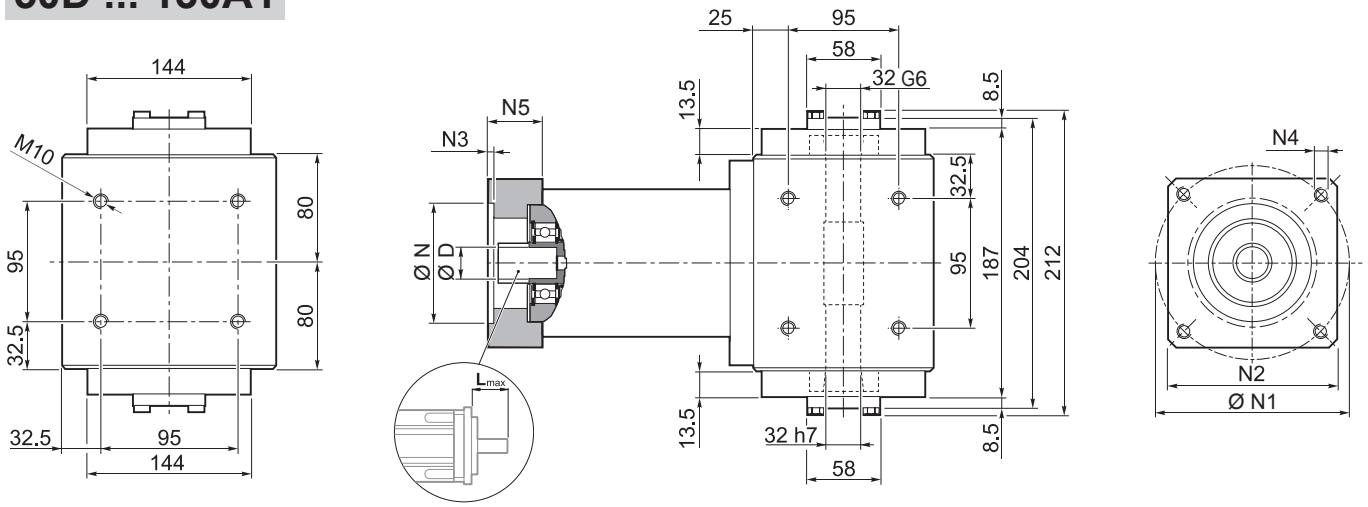

	
TR MB 105 2	32
TR MB 105 3	34
TR MB 105 4	36

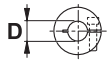
											N	N1	N2	N3	N4	N5	L _{max}	
50D	11	12	12.7	14	15	15.875	16	19	-	-	-	50	95	100	5	M6x14	28	40
55A	11	12	12.7	14	15	15.875	16	19	-	-	-	55	125.7	105	5	M6x16	28	40
60A2	11	12	12.7	14	15	15.875	16	19	-	-	-	60	75	100	6.5	M5x14	28	40
60AH2	11	12	12.7	14	15	15.875	16	19	-	-	-	60	75	100	4	6.5	33	40
60B1	11	12	12.7	14	15	15.875	16	19	-	-	-	60	85	100	6.5	M5x14	28	40
70A1	11	12	12.7	14	15	15.875	16	19	-	-	-	70	85	100	6.5	M6x14	28	40
70AH1	11	12	12.7	14	15	15.875	16	19	-	-	-	70	85	100	4	6.5	33	40
70B1	11	12	12.7	14	15	15.875	16	19	-	-	-	70	90	100	6.5	M5x12	28	40
80A1	11	12	12.7	14	15	15.875	16	19	-	-	-	80	100	100	6.5	M6x16	28	40
80AH1	11	12	12.7	14	15	15.875	16	19	-	-	-	80	100	100	4	6.5	33	40
95A	11	12	12.7	14	15	15.875	16	19	-	-	-	95	115	100	6.5	M8x18	28	40
95A1	11	12	12.7	14	15	15.875	16	19	22	24	-	95	115	100	6.5	M8x18	38	50
95B	11	12	12.7	14	15	15.875	16	19	-	-	-	95	130	115	6.5	M8x18	28	40
110A	11	12	12.7	14	15	15.875	16	19	-	-	-	110	130	115	6.5	M8x18	28	40
110A1	11	12	12.7	14	15	15.875	16	19	22	24	-	110	130	115	6.5	M8x20	38	50
110B	11	12	12.7	14	15	15.875	16	19	22	24	-	110	145	120	6.5	M8x20	38	50
110B1	11	12	12.7	14	15	15.875	16	19	22	24	28	110	145	120	6.5	M8x20	48	60
130A	11	12	12.7	14	15	15.875	16	19	22	24	-	130	165	140	6.5	M10x20	38	50
130A1	11	12	12.7	14	15	15.875	16	19	22	24	28	130	165	140	6.5	M10x25	48	60

Für weitere Motoradapter und Antriebswellenbohrungen bitte nachfragen.

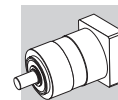

TR MB 105

FM

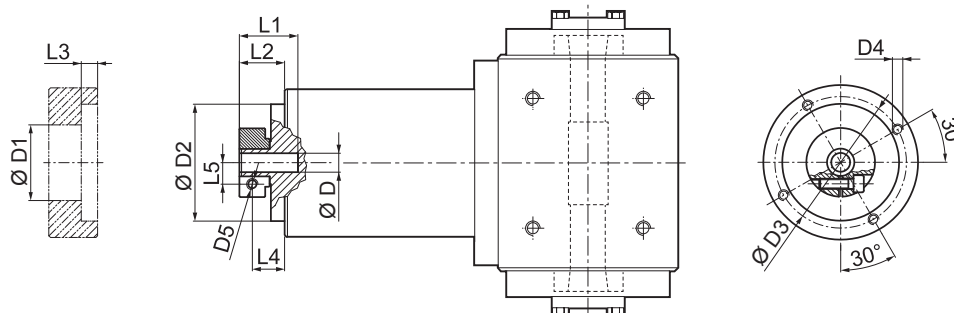

D				D1	D2	D3	D4	D5	L1	L2	L3	L4	L5
11	12	12.7		43	90	98	M6x15	M6	31.5	19.5	7.6	12	12.5
14	15	15.875	16	48	90	98	M6x15	M6	31.5	19.5	7.6	12	14.5
19				51	90	98	M6x15	M6	31.5	19.5	7.6	12	16.5
22	24			56.5	90	98	M6x15	M6	35	23	7.6	12	19
28				67	90	98	M6x15	M8	35	23	7.6	14	22.5
32				71	90	98	M6x15	M8	37	25	7.6	16	24.5

i	M _{n2} [Nm]	M _{a2} [Nm]	M _{p2} [Nm]	n ₁ [min ⁻¹]	n _{1 max} [min ⁻¹]	Ψ _S [arcmin]	Ψ _R [arcmin]	C _t [Nm / arcmin]	η %	J _G [kgcm ²]			
										D			
										11 ... 12.7	14 ... 19	22 - 24	28 - 32
TR MB 105 2_3	100	180	360	2500	3500	5'	3'	24.0	94	1.70	1.78	2.22	2.59
TR MB 105 2_4	140	210	450	2800	4500	5'	3'	24.0	94	0.99	1.06	1.51	1.87
TR MB 105 2_5	140	210	450	3000	4500	5'	3'	24.0	94	0.72	0.79	1.23	1.60
TR MB 105 2_6	140	210	450	3000	4500	5'	3'	24.0	94	0.36	0.43	0.88	1.24
TR MB 105 2_7	140	210	450	3500	5000	5'	3'	24.0	94	0.47	0.55	0.99	1.35
TR MB 105 2_10	100	180	360	3500	5000	5'	3'	24.0	94	0.33	0.41	0.85	1.21
TR MB 105 3_9	100	180	360	2500	3500	5'	3'	21.5	91	1.58	1.63	2.07	2.44
TR MB 105 3_12	170	250	600	2500	3500	5'	3'	21.5	91	1.52	1.59	2.03	2.40
TR MB 105 3_15	170	250	600	2500	3500	5'	3'	21.5	91	1.47	1.55	1.99	2.36
TR MB 105 3_16	170	250	600	2800	4500	5'	3'	21.5	91	0.87	0.95	1.39	1.76
TR MB 105 3_20	170	250	600	3000	4500	5'	3'	21.5	91	0.86	0.93	1.37	1.74
TR MB 105 3_25	170	250	600	3000	4500	5'	3'	21.5	91	0.63	0.71	1.15	1.51
TR MB 105 3_28	170	250	600	3500	5000	5'	3'	21.5	91	0.43	0.51	0.95	1.32
TR MB 105 3_30	100	180	360	3500	5000	5'	3'	21.5	91	0.32	0.40	0.84	1.20
TR MB 105 3_35	170	250	600	3500	5000	5'	3'	21.5	91	0.43	0.50	0.95	1.31
TR MB 105 3_36	140	210	450	3000	4500	5'	3'	21.5	91	0.32	0.39	0.84	1.20
TR MB 105 3_40	170	250	600	3500	5000	5'	3'	21.5	91	0.31	0.39	0.83	1.20
TR MB 105 3_50	170	250	600	3500	5000	5'	3'	21.5	91	0.31	0.39	0.83	1.19
TR MB 105 3_70	170	250	600	3500	5000	5'	3'	21.5	91	0.31	0.38	0.83	1.19
TR MB 105 3_100	100	180	360	3500	5000	5'	3'	21.5	91	0.31	0.38	0.83	1.19
TR MB 105 4_48	170	250	600	2800	4500	7'	5'	18.0	89	0.91	0.98	1.42	1.79
TR MB 105 4_64	170	250	600	2800	4500	7'	5'	18.0	89	0.87	0.94	1.38	1.75
TR MB 105 4_75	170	250	600	3000	4500	7'	5'	18.0	89	0.66	0.74	1.18	1.55
TR MB 105 4_80	170	250	600	2800	4500	7'	5'	18.0	89	0.86	0.94	1.38	1.75
TR MB 105 4_84	170	250	600	3500	5000	7'	5'	18.0	89	0.44	0.52	0.96	1.33
TR MB 105 4_90	100	180	360	3500	5000	7'	5'	18.0	89	0.32	0.39	0.84	1.20
TR MB 105 4_120	170	250	600	3500	5000	7'	5'	18.0	89	0.32	0.39	0.84	1.20
TR MB 105 4_125	170	250	600	3000	4500	7'	5'	18.0	89	0.63	0.70	1.15	1.51
TR MB 105 4_140	170	250	600	3500	5000	7'	5'	18.0	89	0.43	0.51	0.95	1.32
TR MB 105 4_150	170	250	600	3500	5000	7'	5'	18.0	89	0.32	0.39	0.84	1.20
TR MB 105 4_160	170	250	600	3500	5000	7'	5'	18.0	89	0.31	0.39	0.83	1.21
TR MB 105 4_175	170	250	600	3500	5000	7'	5'	18.0	89	0.43	0.50	0.95	1.31
TR MB 105 4_200	170	250	600	3500	5000	7'	5'	18.0	89	0.31	0.39	0.83	1.20
TR MB 105 4_210	170	250	600	3500	5000	7'	5'	18.0	89	0.32	0.39	0.84	1.20
TR MB 105 4_216	170	250	600	3000	4500	7'	5'	18.0	89	0.31	0.39	0.83	1.20
TR MB 105 4_250	170	250	600	3500	5000	7'	5'	18.0	89	0.31	0.39	0.83	1.19
TR MB 105 4_280	170	250	600	3500	5000	7'	5'	18.0	89	0.31	0.38	0.83	1.19
TR MB 105 4_350	170	250	600	3500	5000	7'	5'	18.0	89	0.31	0.38	0.83	1.19
TR MB 105 4_400	170	250	600	3500	5000	7'	5'	18.0	89	0.31	0.38	0.83	1.19
TR MB 105 4_500	170	250	600	3500	5000	7'	5'	18.0	89	0.31	0.38	0.83	1.19
TR MB 105 4_700	170	250	600	3500	5000	7'	5'	18.0	89	0.31	0.38	0.83	1.19
TR MB 105 4_1000	100	180	360	3500	5000	7'	5'	18.0	89	0.31	0.38	0.83	1.19

TR



TR 130

IS

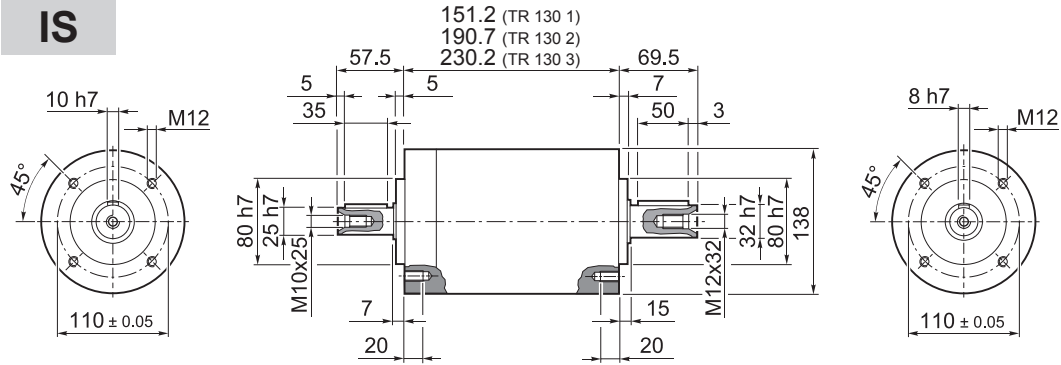

TR 130 1	12.0
TR 130 2	15.5
TR 130 3	18.5

TR

55A1 ... 180A1

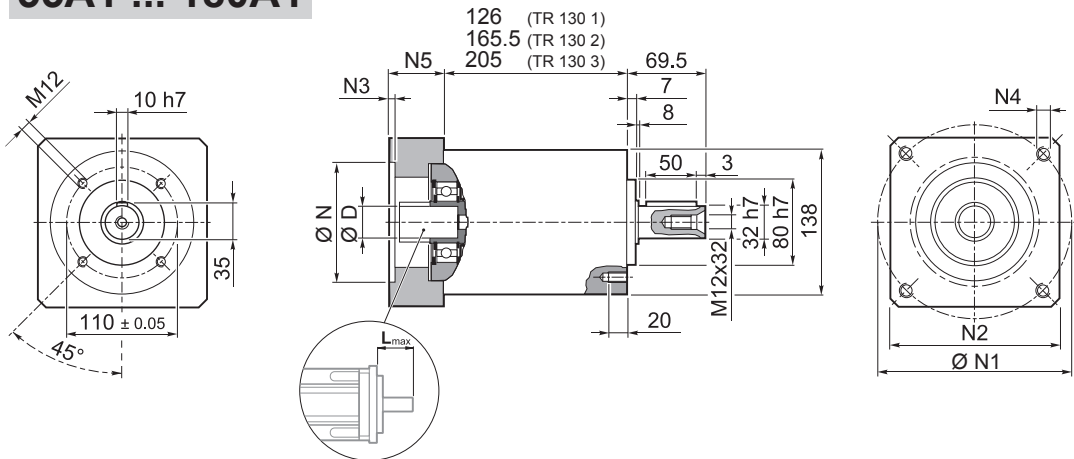

TR 130 1	12.0
TR 130 2	15.5
TR 130 3	18.5

											N	N1	N2	N3	N4	N5	L _{max}
	14	15.875	16	19													
55A1	14	15.875	16	19	-	-	-	-	-	-	55.5	125.7	130	4	M6x15	39.5	50
80A2	14	15.875	16	19	-	-	-	-	-	-	80	100	130	4	M6x15	39.5	50
95A1	14	15.875	16	19	22	24	-	-	-	-	95	115	130	4	M8x20	39.5	50
110A1	14	15.875	16	19	22	24	-	-	-	-	110	130	130	4	M8x20	39.5	50
110B1	14	15.875	16	19	22	24	-	-	-	-	110	145	130	6.5	M8x20	49.5	60
114A0	14	15.875	16	19	22	24	-	-	-	-	114.3	200	170	5.5	M12x25	39.5	50
114A	14	15.875	16	19	22	24	28	32	35	38	114.3	200	170	5.5	M12x25	69.5	80
130A	14	15.875	16	19	22	24	-	-	-	-	130	165	140	4	M10x20	39.5	50
130A1	14	15.875	16	19	22	24	28	32	-	-	130	165	140	4	M10x20	49.5	60
180A	14	15.875	16	19	22	24	28	32	-	-	180	215	190	5.5	M14x25	49.5	60
180A1	14	15.875	16	19	22	24	28	32	35	38	180	215	190	5.5	M14x25	69.5	80

Für weitere Motoradapter und Antriebswellenbohrungen bitte nachfragen.

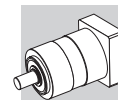

TR 130

FM

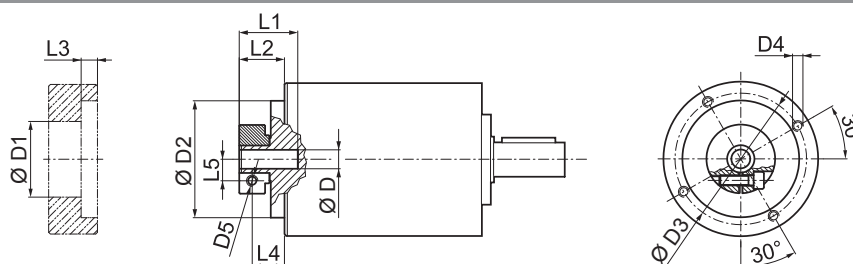

	D1	D2	D3	D4	D5	L1	L2	L3	L4	L5
14 15.875 16	48	113	125.5	M8x15	M6	40	27.5	6	20	14.5
19	51	113	125.5	M8x15	M6	40	27.5	6	20	16.5
22 24	56.5	113	125.5	M8x15	M6	41	28.5	6	19.5	19
28	67	113	125.5	M8x15	M8	41	28.5	6	19.5	22.5
32	71	113	125.5	M8x15	M8	41	28.5	6	19.5	24.5
35	73	113	125.5	M8x15	M8	50	37.5	11.25	26	26
38	77.5	113	125.5	M8x15	M8	50	37.5	11.25	26	28

	M_{n2}	M_{a2}	M_{p2}	n_1	$n_{1\max}$	φ_S	φ_R	C_t	$R_{1\max}$	$R_{2\max}$	$A_{2\max}$	η	J_G [kgcm ²]			
													D	14 ... 19	22 - 24	28 - 32
i	[Nm]	[Nm]	[Nm]	[min ⁻¹]	[min ⁻¹]	[arcmin]		$\frac{Nm}{aromin}$	[N]	[N]	[N]	%				
TR 130 1_3	215	400	800	2100	3000	5'	3'	45.0	800	5500	6500	97	5.25	5.46	5.81	7.16
TR 130 1_4	380	600	1100	2400	3500	5'	3'	45.0	800	5500	6500	97	3.06	3.26	3.61	4.97
TR 130 1_5	380	600	1100	2900	3500	5'	3'	45.0	800	5500	6500	97	2.22	2.42	2.77	4.13
TR 130 1_6	380	600	1100	2900	3500	5'	3'	45.0	800	5500	6500	97	1.19	1.40	1.75	3.10
TR 130 1_7	380	600	1100	3200	4000	5'	3'	45.0	800	5500	6500	97	1.47	1.68	2.03	3.38
TR 130 1_10	215	400	800	3200	4000	5'	3'	45.0	800	5500	6500	97	1.04	1.25	1.60	2.95
TR 130 2_9	215	400	800	2100	3000	5'	3'	38.5	800	5500	6500	94	4.82	5.02	5.37	6.72
TR 130 2_12	450	700	1300	2100	3000	5'	3'	38.5	800	5500	6500	94	4.57	4.78	5.13	6.48
TR 130 2_15	450	700	1300	2100	3000	5'	3'	38.5	800	5500	6500	94	4.48	4.69	5.04	6.39
TR 130 2_16	450	700	1300	2400	3500	5'	3'	38.5	800	5500	6500	94	2.67	2.88	3.23	4.58
TR 130 2_20	450	700	1300	2900	3500	5'	3'	38.5	800	5500	6500	94	1.97	2.18	2.53	3.88
TR 130 2_25	450	700	1300	2900	3500	5'	3'	38.5	800	5500	6500	94	1.94	2.15	2.50	3.85
TR 130 2_28	450	700	1300	3200	4000	5'	3'	38.5	800	5500	6500	94	1.34	1.55	1.90	3.25
TR 130 2_30	215	400	800	3200	4000	5'	3'	38.5	800	5500	6500	94	1.00	1.21	1.56	2.91
TR 130 2_35	450	700	1300	3200	4000	5'	3'	38.5	800	5500	6500	94	1.33	1.53	1.88	3.24
TR 130 2_36	380	600	1100	2900	3500	5'	3'	38.5	800	5500	6500	94	1.05	1.26	1.61	2.96
TR 130 2_40	450	700	1300	3200	4000	5'	3'	38.5	800	5500	6500	94	0.98	1.19	1.54	2.89
TR 130 2_50	450	700	1300	3200	4000	5'	3'	38.5	800	5500	6500	94	0.97	1.18	1.53	2.88
TR 130 2_70	450	700	1300	3200	4000	5'	3'	38.5	800	5500	6500	94	0.96	1.17	1.52	2.87
TR 130 2_100	215	400	800	3200	4000	5'	3'	38.5	800	5500	6500	94	0.96	1.17	1.52	2.87
TR 130 3_48	450	700	1300	2400	3500	7'	5'	30.0	800	5500	6500	91	2.77	2.98	3.33	4.68
TR 130 3_64	450	700	1300	2400	3500	7'	5'	30.0	800	5500	6500	91	2.65	2.86	3.21	4.56
TR 130 3_75	450	700	1300	2900	3500	7'	5'	30.0	800	5500	6500	91	2.03	2.24	2.59	3.94
TR 130 3_80	450	700	1300	2400	3500	7'	5'	30.0	800	5500	6500	91	2.65	2.85	3.20	4.56
TR 130 3_84	450	700	1300	3200	4000	7'	5'	30.0	800	5500	6500	91	1.37	1.58	1.93	3.28
TR 130 3_90	215	400	800	3200	4000	7'	5'	30.0	800	5500	6500	91	1.00	1.20	1.55	2.91
TR 130 3_120	450	700	1300	3200	4000	7'	5'	30.0	800	5500	6500	91	0.99	1.20	1.55	2.90
TR 130 3_125	450	700	1300	2900	3500	7'	5'	30.0	800	5500	6500	91	1.93	2.13	2.48	3.84
TR 130 3_140	450	700	1300	3200	4000	7'	5'	30.0	800	5500	6500	91	1.34	1.54	1.89	3.25
TR 130 3_150	450	700	1300	3200	4000	7'	5'	30.0	800	5500	6500	91	0.99	1.20	1.55	2.90
TR 130 3_160	450	700	1300	3200	4000	7'	5'	30.0	800	5500	6500	91	0.98	1.18	1.53	2.89
TR 130 3_175	450	700	1300	3200	4000	7'	5'	30.0	800	5500	6500	91	1.32	1.53	1.88	3.23
TR 130 3_200	450	700	1300	3200	4000	7'	5'	30.0	800	5500	6500	91	0.97	1.18	1.53	2.88
TR 130 3_210	450	700	1300	3200	4000	7'	5'	30.0	800	5500	6500	91	0.99	1.20	1.55	2.90
TR 130 3_216	450	700	1300	2900	3500	7'	5'	30.0	800	5500	6500	91	1.05	1.26	1.61	2.96
TR 130 3_250	450	700	1300	3200	4000	7'	5'	30.0	800	5500	6500	91	0.97	1.18	1.53	2.88
TR 130 3_280	450	700	1300	3200	4000	7'	5'	30.0	800	5500	6500	91	0.96	1.17	1.52	2.87
TR 130 3_350	450	700	1300	3200	4000	7'	5'	30.0	800	5500	6500	91	0.96	1.17	1.52	2.87
TR 130 3_400	450	700	1300	3200	4000	7'	5'	30.0	800	5500	6500	91	0.96	1.17	1.52	2.87
TR 130 3_500	450	700	1300	3200	4000	7'	5'	30.0	800	5500	6500	91	0.96	1.17	1.52	2.87
TR 130 3_700	450	700	1300	3200	4000	7'	5'	30.0	800	5500	6500	91	0.96	1.17	1.52	2.87
TR 130 3_1000	215	400	800	3200	4000	7'	5'	30.0	800	5500	6500	91	0.96	1.17	1.52	2.87

TR



TR G 130

55A1 ... 180A1

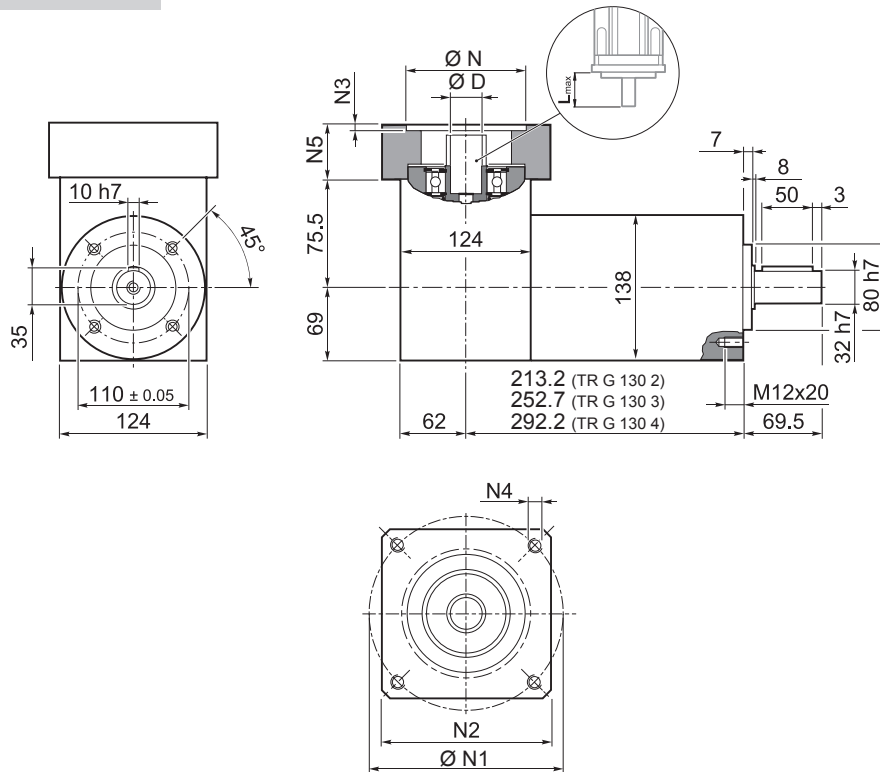

TR G 130 2	16.0
TR G 130 3	19.5
TR G 130 4	22.5

TR

											N	N1	N2	N3	N4	N5	L _{max}
55A1	14	15.875	16	19	-	-	-	-	-	-	55.5	125.7	130	4	M6x15	39.5	50
80A2	14	15.875	16	19	-	-	-	-	-	-	80	100	130	4	M6x15	39.5	50
95A1	14	15.875	16	19	22	24	-	-	-	-	95	115	130	4	M8x20	39.5	50
110A1	14	15.875	16	19	22	24	-	-	-	-	110	130	130	4	M8x20	39.5	50
110B1	14	15.875	16	19	22	24	-	-	-	-	110	145	130	6.5	M8x20	49.5	60
114A0	14	15.875	16	19	22	24	-	-	-	-	114.3	200	170	5.5	M12x25	39.5	50
114A	14	15.875	16	19	22	24	28	32	35	38	114.3	200	170	5.5	M12x25	69.5	80
130A	14	15.875	16	19	22	24	-	-	-	-	130	165	140	4	M10x20	39.5	50
130A1	14	15.875	16	19	22	24	28	32	-	-	130	165	140	4	M10x20	49.5	60
180A	14	15.875	16	19	22	24	28	32	-	-	180	215	190	5.5	M14x25	49.5	60
180A1	14	15.875	16	19	22	24	28	32	35	38	180	215	190	5.5	M14x25	69.5	80

Für weitere Motoradapter und Antriebswellenbohrungen bitte nachfragen.

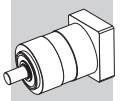

TR G 130

FM

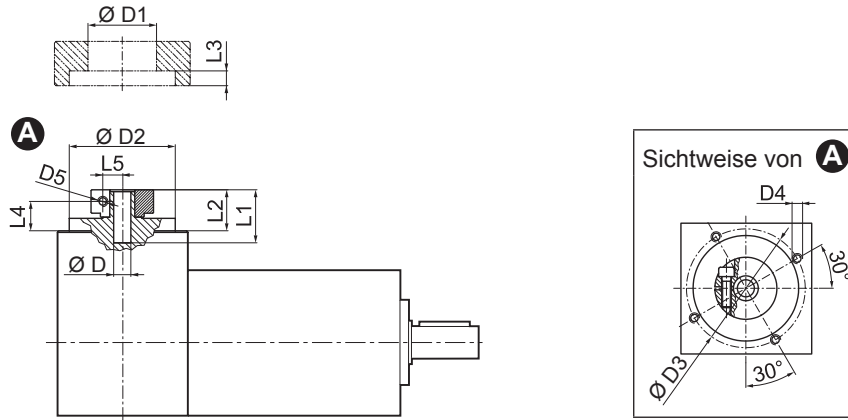

D			D1	D2	D3	D4	D5	L1	L2	L3	L4	L5
14	15.875	16	48	113	125.5	M8x15	M6	40	27.5	6	20	14.5
19			51	113	125.5	M8x15	M6	40	27.5	6	20	16.5
22	24		56.5	113	125.5	M8x15	M6	41	28.5	6	19.5	19
28			67	113	125.5	M8x15	M8	41	28.5	6	19.5	22.5
32			71	113	125.5	M8x15	M8	41	28.5	6	19.5	24.5
35			73	113	125.5	M8x15	M8	50	37.5	11.25	26	26
38			77.5	113	125.5	M8x15	M8	50	37.5	11.25	26	28

TR

i	M _{n 2} [Nm]	M _{a 2} [Nm]	M _{p 2} [Nm]	n ₁ [min ⁻¹]	n _{1 max} [min ⁻¹]	Ψ _S [arcmin]	Ψ _R	C _t [Nm/arcmin]	R _{2 max} [N]	A _{2 max} [N]	η %	J _e [kgcm ²]			
												D			
												14 ... 19	22 - 24	28 - 32	35 - 38
TR G 130 2_3	215	400	800	2100	3000	5'	3'	45.0	5500	6500	94	7.09	7.28	7.66	10.37
TR G 130 2_4	380	600	1100	2400	3500	5'	3'	45.0	5500	6500	94	4.90	5.08	5.46	8.18
TR G 130 2_5	380	600	1100	2900	3500	5'	3'	45.0	5500	6500	94	4.81	4.99	5.38	8.10
TR G 130 2_6	380	600	1100	2900	3500	5'	3'	45.0	5500	6500	94	4.45	4.64	5.03	7.73
TR G 130 2_7	380	600	1100	3200	4000	5'	3'	45.0	5500	6500	94	4.73	4.92	5.31	8.01
TR G 130 2_10	215	400	800	3200	4000	5'	3'	45.0	5500	6500	94	4.68	4.88	5.26	7.97
TR G 130 3_9	215	400	800	2100	3000	5'	3'	38.5	5500	6500	91	6.66	6.84	7.22	9.93
TR G 130 3_12	450	700	1300	2100	3000	5'	3'	38.5	5500	6500	91	6.25	6.45	6.84	9.54
TR G 130 3_15	450	700	1300	2100	3000	5'	3'	38.5	5500	6500	91	6.25	6.44	6.83	9.53
TR G 130 3_16	450	700	1300	2400	3500	5'	3'	38.5	5500	6500	91	4.51	4.70	5.08	7.79
TR G 130 3_20	450	700	1300	2900	3500	5'	3'	38.5	5500	6500	91	4.56	5.36	5.75	8.45
TR G 130 3_25	450	700	1300	2900	3500	5'	3'	38.5	5500	6500	91	5.13	4.72	5.11	7.82
TR G 130 3_28	450	700	1300	3200	4000	5'	3'	38.5	5500	6500	91	4.60	4.79	5.18	7.88
TR G 130 3_30	215	400	800	3200	4000	5'	3'	38.5	5500	6500	91	4.64	4.84	5.22	7.93
TR G 130 3_35	450	700	1300	3200	4000	5'	3'	38.5	5500	6500	91	4.92	5.10	5.49	8.20
TR G 130 3_36	380	600	1100	2900	3500	5'	3'	38.5	5500	6500	91	4.31	4.50	4.89	7.59
TR G 130 3_40	450	700	1300	3200	4000	5'	3'	38.5	5500	6500	91	4.77	4.96	5.35	8.05
TR G 130 3_50	450	700	1300	3200	4000	5'	3'	38.5	5500	6500	91	4.76	4.96	5.34	8.05
TR G 130 3_70	450	700	1300	3200	4000	5'	3'	38.5	5500	6500	91	4.60	4.80	5.18	7.89
TR G 130 3_100	215	400	800	3200	4000	5'	3'	38.5	5500	6500	91	4.60	4.80	5.18	7.89
TR G 130 4_48	450	700	1300	2400	3500	7'	5'	30.0	5500	6500	89	4.61	4.81	5.18	7.89
TR G 130 4_64	450	700	1300	2400	3500	7'	5'	30.0	5500	6500	89	4.49	4.68	5.06	7.77
TR G 130 4_75	450	700	1300	2900	3500	7'	5'	30.0	5500	6500	89	4.62	4.81	5.20	7.91
TR G 130 4_80	450	700	1300	2400	3500	7'	5'	30.0	5500	6500	89	4.49	4.67	5.05	7.77
TR G 130 4_84	450	700	1300	3200	4000	7'	5'	30.0	5500	6500	89	4.63	4.82	5.21	7.91
TR G 130 4_90	215	400	800	3200	4000	7'	5'	30.0	5500	6500	89	4.64	4.83	5.21	7.93
TR G 130 4_120	450	700	1300	3200	4000	7'	5'	30.0	5500	6500	89	4.63	4.83	5.21	7.92
TR G 130 4_125	450	700	1300	2900	3500	7'	5'	30.0	5500	6500	89	4.52	4.70	5.09	7.81
TR G 130 4_140	450	700	1300	3200	4000	7'	5'	30.0	5500	6500	89	4.60	4.78	5.17	7.88
TR G 130 4_150	450	700	1300	3200	4000	7'	5'	30.0	5500	6500	89	4.63	4.83	5.21	7.92
TR G 130 4_160	450	700	1300	3200	4000	7'	5'	30.0	5500	6500	89	4.62	4.81	5.19	7.91
TR G 130 4_175	450	700	1300	3200	4000	7'	5'	30.0	5500	6500	89	4.58	4.77	5.16	7.86
TR G 130 4_200	450	700	1300	3200	4000	7'	5'	30.0	5500	6500	89	4.61	4.81	5.19	7.90
TR G 130 4_210	450	700	1300	3200	4000	7'	5'	30.0	5500	6500	89	4.63	4.83	5.21	7.92
TR G 130 4_216	450	700	1300	2900	3500	7'	5'	30.0	5500	6500	89	4.31	4.50	4.89	7.59
TR G 130 4_250	450	700	1300	3200	4000	7'	5'	30.0	5500	6500	89	4.61	4.81	5.19	7.90
TR G 130 4_280	450	700	1300	3200	4000	7'	5'	30.0	5500	6500	89	4.60	4.80	5.18	7.89
TR G 130 4_350	450	700	1300	3200	4000	7'	5'	30.0	5500	6500	89	4.60	4.80	5.18	7.89
TR G 130 4_400	450	700	1300	3200	4000	7'	5'	30.0	5500	6500	89	4.60	4.80	5.18	7.89
TR G 130 4_500	450	700	1300	3200	4000	7'	5'	30.0	5500	6500	89	4.60	4.80	5.18	7.89
TR G 130 4_700	450	700	1300	3200	4000	7'	5'	30.0	5500	6500	89	4.60	4.80	5.18	7.89
TR G 130 4_1000	215	400	800	3200	4000	7'	5'	30.0	5500	6500	89	4.60	4.80	5.18	7.89



TR MB 130

55A1 ... 180A1

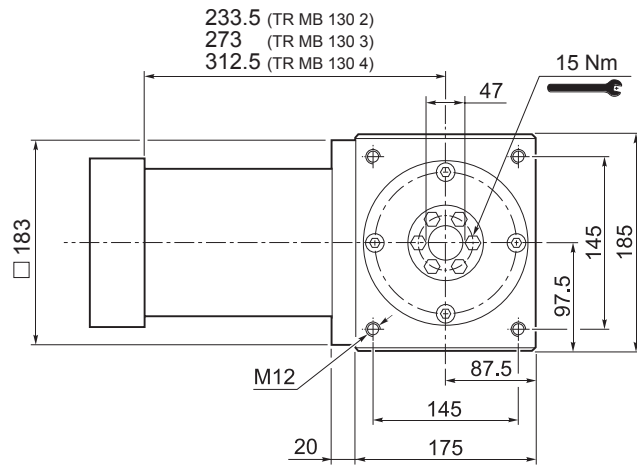
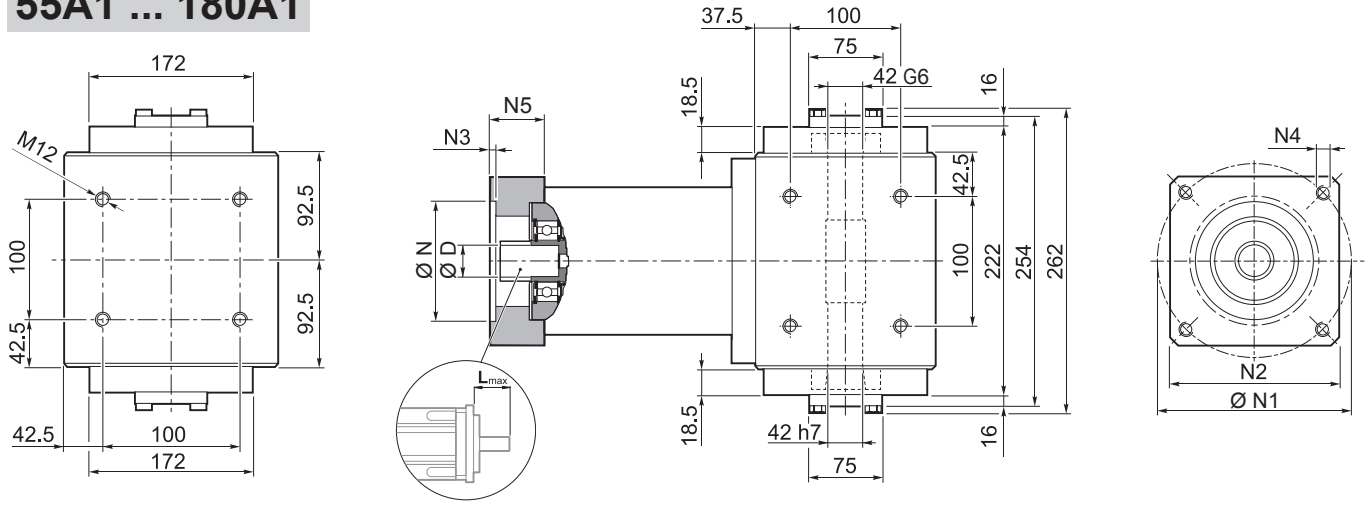

TR MB 130 2	54
TR MB 130 3	58
TR MB 130 4	61

												N	N1	N2	N3	N4	N5	L _{max}
	14	15.875	16	19														
55A1	14	15.875	16	19	-	-	-	-	-	-	-	55.5	125.7	130	4	M6x15	39.5	50
80A2	14	15.875	16	19	-	-	-	-	-	-	-	80	100	130	4	M6x15	39.5	50
95A1	14	15.875	16	19	22	24	-	-	-	-	-	95	115	130	4	M8x20	39.5	50
110A1	14	15.875	16	19	22	24	-	-	-	-	-	110	130	130	4	M8x20	39.5	50
110B1	14	15.875	16	19	22	24	-	-	-	-	-	110	145	130	6.5	M8x20	49.5	60
114A0	14	15.875	16	19	22	24	-	-	-	-	-	114.3	200	170	5.5	M12x25	39.5	50
114A	14	15.875	16	19	22	24	28	32	35	38	-	114.3	200	170	5.5	M12x25	69.5	80
130A	14	15.875	16	19	22	24	-	-	-	-	-	130	165	140	4	M10x20	39.5	50
130A1	14	15.875	16	19	22	24	28	32	-	-	-	130	165	140	4	M10x20	49.5	60
180A	14	15.875	16	19	22	24	28	32	-	-	-	180	215	190	5.5	M14x25	49.5	60
180A1	14	15.875	16	19	22	24	28	32	35	38	-	180	215	190	5.5	M14x25	69.5	80

Für weitere Motoradapter und Antriebswellenbohrungen bitte nachfragen.

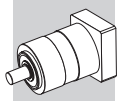

TR MB 130

FM

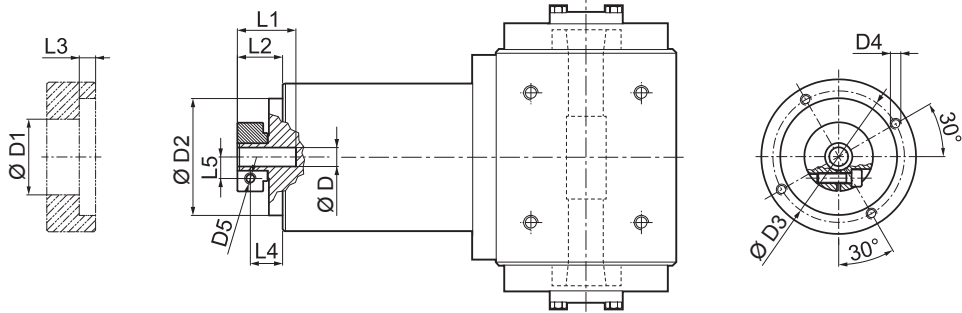

	D1	D2	D3	D4	D5	L1	L2	L3	L4	L5
14 15.875 16	48	113	125.5	M8x15	M6	40	27.5	6	20	14.5
19	51	113	125.5	M8x15	M6	40	27.5	6	20	16.5
22 24	56.5	113	125.5	M8x15	M6	41	28.5	6	19.5	19
28	67	113	125.5	M8x15	M8	41	28.5	6	19.5	22.5
32	71	113	125.5	M8x15	M8	41	28.5	6	19.5	24.5
35	73	113	125.5	M8x15	M8	50	37.5	11.25	26	26
38	77.5	113	125.5	M8x15	M8	50	37.5	11.25	26	28

	i	M_{n2} [Nm]	M_{a2} [Nm]	M_{p2} [Nm]	n_1 [min ⁻¹]	n_{1max} [min ⁻¹]	φ_s [arcmin]	φ_R	C_t [Nm/arcmin]	η %	J_G [kgcm ²]			
												14 ... 19	22 - 24	28 - 32
TR MB 130 2_3		215	400	800	2100	3000	5'	3'	45.0	94	5.25	5.46	5.81	7.16
TR MB 130 2_4		380	600	1100	2400	3500	5'	3'	45.0	94	3.06	3.26	3.61	4.97
TR MB 130 2_5		380	600	1100	2900	3500	5'	3'	45.0	94	2.22	2.42	2.77	4.13
TR MB 130 2_6		380	600	1100	2900	3500	5'	3'	45.0	94	1.19	1.40	1.75	3.10
TR MB 130 2_7		380	600	1100	3200	4000	5'	3'	45.0	94	1.47	1.68	2.03	3.38
TR MB 130 2_10		215	400	800	3200	4000	5'	3'	45.0	94	1.04	1.25	1.60	2.95
TR MB 130 3_9		215	400	800	2100	3000	5'	3'	38.5	91	4.82	5.02	5.37	6.72
TR MB 130 3_12		450	700	1300	2100	3000	5'	3'	38.5	91	4.57	4.78	5.13	6.48
TR MB 130 3_15		450	700	1300	2100	3000	5'	3'	38.5	91	4.48	4.69	5.04	6.39
TR MB 130 3_16		450	700	1300	2400	3500	5'	3'	38.5	91	2.67	2.88	3.23	4.58
TR MB 130 3_20		450	700	1300	2900	3500	5'	3'	38.5	91	1.97	2.18	2.53	3.88
TR MB 130 3_25		450	700	1300	2900	3500	5'	3'	38.5	91	1.94	2.15	2.50	3.85
TR MB 130 3_28		450	700	1300	3200	4000	5'	3'	38.5	91	1.34	1.55	1.90	3.25
TR MB 130 3_30		215	400	800	3200	4000	5'	3'	38.5	91	1.00	1.21	1.56	2.91
TR MB 130 3_35		450	700	1300	3200	4000	5'	3'	38.5	91	1.33	1.53	1.88	3.24
TR MB 130 3_36		380	600	1100	2900	3500	5'	3'	38.5	91	1.05	1.26	1.61	2.96
TR MB 130 3_40		450	700	1300	3200	4000	5'	3'	38.5	91	0.98	1.19	1.54	2.89
TR MB 130 3_50		450	700	1300	3200	4000	5'	3'	38.5	91	0.97	1.18	1.53	2.88
TR MB 130 3_70		450	700	1300	3200	4000	5'	3'	38.5	91	0.96	1.17	1.52	2.87
TR MB 130 3_100		215	400	800	3200	4000	5'	3'	38.5	91	0.96	1.17	1.52	2.87
TR MB 130 4_48		450	700	1300	2400	3500	7'	5'	30.0	89	2.77	2.98	3.33	4.68
TR MB 130 4_64		450	700	1300	2400	3500	7'	5'	30.0	89	2.65	2.86	3.21	4.56
TR MB 130 4_75		450	700	1300	2900	3500	7'	5'	30.0	89	2.03	2.24	2.59	3.94
TR MB 130 4_80		450	700	1300	2400	3500	7'	5'	30.0	89	2.65	2.85	3.20	4.56
TR MB 130 4_84		450	700	1300	3200	4000	7'	5'	30.0	89	1.37	1.58	1.93	3.28
TR MB 130 4_90		215	400	800	3200	4000	7'	5'	30.0	89	1.00	1.20	1.55	2.91
TR MB 130 4_120		450	700	1300	3200	4000	7'	5'	30.0	89	0.99	1.20	1.55	2.90
TR MB 130 4_125		450	700	1300	2900	3500	7'	5'	30.0	89	1.93	2.13	2.48	3.84
TR MB 130 4_140		450	700	1300	3200	4000	7'	5'	30.0	89	1.34	1.54	1.89	3.25
TR MB 130 4_150		450	700	1300	3200	4000	7'	5'	30.0	89	0.99	1.20	1.55	2.90
TR MB 130 4_160		450	700	1300	3200	4000	7'	5'	30.0	89	0.98	1.18	1.53	2.89
TR MB 130 4_175		450	700	1300	3200	4000	7'	5'	30.0	89	1.32	1.53	1.88	3.23
TR MB 130 4_200		450	700	1300	3200	4000	7'	5'	30.0	89	0.97	1.18	1.53	2.88
TR MB 130 4_210		450	700	1300	3200	4000	7'	5'	30.0	89	0.99	1.20	1.55	2.90
TR MB 130 4_216		450	700	1300	2900	3500	7'	5'	30.0	89	1.05	1.26	1.61	2.96
TR MB 130 4_250		450	700	1300	3200	4000	7'	5'	30.0	89	0.97	1.18	1.53	2.88
TR MB 130 4_280		450	700	1300	3200	4000	7'	5'	30.0	89	0.96	1.17	1.52	2.87
TR MB 130 4_350		450	700	1300	3200	4000	7'	5'	30.0	89	0.96	1.17	1.52	2.87
TR MB 130 4_400		450	700	1300	3200	4000	7'	5'	30.0	89	0.96	1.17	1.52	2.87
TR MB 130 4_500		450	700	1300	3200	4000	7'	5'	30.0	89	0.96	1.17	1.52	2.87
TR MB 130 4_700		450	700	1300	3200	4000	7'	5'	30.0	89	0.96	1.17	1.52	2.87
TR MB 130 4_1000		215	400	800	3200	4000	7'	5'	30.0	89	0.96	1.17	1.52	2.87

TR



TR 160

IS

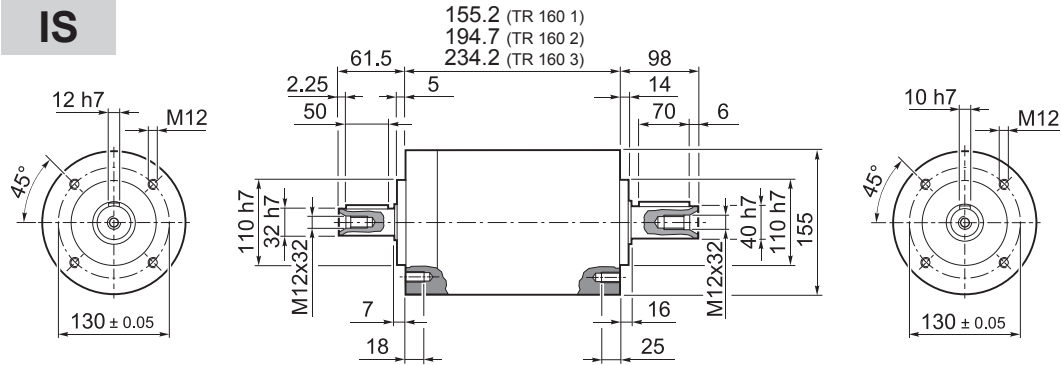

TR 160 1	17.0
TR 160 2	21
TR 160 3	28

TR

55A1 ... 180A1

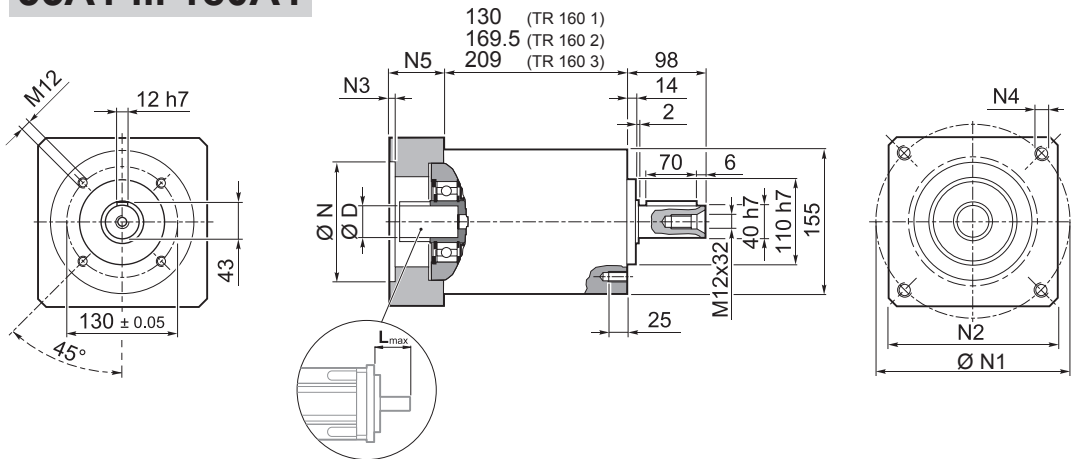

TR 160 1	17.0
TR 160 2	21
TR 160 3	28

											N	N1	N2	N3	N4	N5	L _{max}
55A1	14	15.875	16	19	-	-	-	-	-	-	55.5	125.7	140	5	M6x15	39.5	50
80A2	14	15.875	16	19	-	-	-	-	-	-	80	100	140	5	M6x15	39.5	50
95A1	14	15.875	16	19	22	24	-	-	-	-	95	115	140	5	M8x20	39.5	50
110A1	14	15.875	16	19	22	24	-	-	-	-	110	130	140	5	M8x20	39.5	50
110B1	14	15.875	16	19	22	24	-	-	-	-	110	145	140	6.5	M8x20	49.5	60
114A	14	15.875	16	19	22	24	28	32	35	38	114.3	200	170	6.5	M12x25	69.5	80
130A	14	15.875	16	19	22	24	-	-	-	-	130	165	140	5	M10x20	39.5	50
130A1	14	15.875	16	19	22	24	28	32	-	-	130	165	140	5	M10x20	49.5	60
180A	14	15.875	16	19	22	24	28	32	-	-	180	215	190	6.5	M14x25	49.5	60
180A1	14	15.875	16	19	22	24	28	32	35	38	180	215	190	6.5	M14x25	69.5	80

Für weitere Motoradapter und Antriebswellenbohrungen bitte nachfragen.

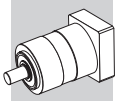

TR 160

FM

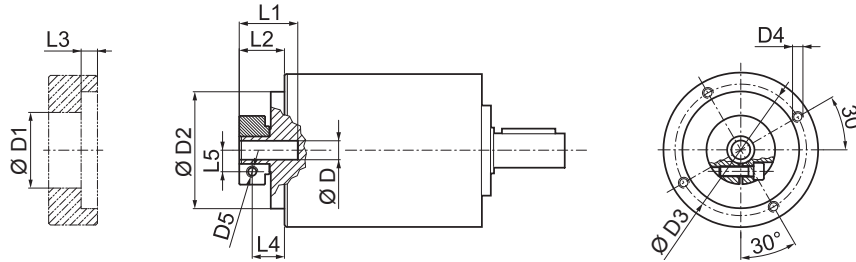

		D1	D2	D3	D4	D5	L1	L2	L3	L4	L5	
14	15.875	16	48	130	142.5	M8x16	M6	40	27.5	6	20	14.5
19			51	130	142.5	M8x16	M6	40	27.5	6	20	16.5
22	24		56.5	130	142.5	M8x16	M6	41	28.5	6	19.5	19
28			67	130	142.5	M8x16	M8	41	28.5	6	19.5	22.5
32			71	130	142.5	M8x16	M8	41	28.5	6	19.5	24.5
35			73	130	142.5	M8x16	M8	50	37.5	11.25	26	26
38			77.5	130	142.5	M8x16	M8	50	37.5	11.25	26	28

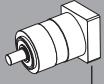
	M _{n2}	M _{a2}	M _{p2}	n ₁	n _{1 max}	φ _S	φ _R	C _t	R _{1 max}	R _{2 max}	A _{2 max}	η	J _e [kgcm ²]				
													i	[Nm]	[Nm]	[Nm]	[min ⁻¹]
TR 160 1_3	350	660	1200	1900	3000	5'	3'	90	1200	6500	7500	97		8.39	8.60	8.95	10.30
TR 160 1_4	500	750	1400	2200	3500	5'	3'	90	1200	6500	7500	97		4.68	4.89	5.24	6.59
TR 160 1_5	500	750	1400	2500	3500	5'	3'	90	1200	6500	7500	97		3.28	3.49	3.84	5.19
TR 160 1_6	500	750	1400	2500	3500	5'	3'	90	1200	6500	7500	97		1.32	1.53	1.88	3.23
TR 160 1_7	500	750	1400	3000	4000	5'	3'	90	1200	6500	7500	97		2.03	2.24	2.59	3.94
TR 160 1_10	350	660	1200	3000	4000	5'	3'	90	1200	6500	7500	97		1.33	1.53	1.88	3.24
TR 160 2_9	350	660	1200	1900	3000	5'	3'	83.5	1200	6500	7500	94		7.51	7.72	8.07	9.42
TR 160 2_12	700	950	1800	1900	3000	5'	3'	83.5	1200	6500	7500	94		7.10	7.30	7.65	9.01
TR 160 2_15	700	950	1800	1900	3000	5'	3'	83.5	1200	6500	7500	94		6.94	7.15	7.50	8.85
TR 160 2_16	700	950	1800	2200	3500	5'	3'	83.5	1200	6500	7500	94		3.95	4.16	4.51	5.86
TR 160 2_20	700	950	1800	2500	3500	5'	3'	83.5	1200	6500	7500	94		2.82	3.02	3.37	4.73
TR 160 2_25	700	950	1800	2500	3500	5'	3'	83.5	1200	6500	7500	94		2.76	2.97	3.32	4.67
TR 160 2_28	700	950	1800	3000	4000	5'	3'	83.5	1200	6500	7500	94		1.79	2.00	2.35	3.70
TR 160 2_30	350	660	1200	3000	4000	5'	3'	83.5	1200	6500	7500	94		1.25	1.46	1.81	3.16
TR 160 2_35	700	950	1800	3000	4000	5'	3'	83.5	1200	6500	7500	94		1.77	1.97	2.32	3.68
TR 160 2_36	500	750	1400	2500	3500	5'	3'	83.5	1200	6500	7500	94		1.06	1.27	1.62	2.97
TR 160 2_40	700	950	1800	3000	4000	5'	3'	83.5	1200	6500	7500	94		1.21	1.42	1.77	3.12
TR 160 2_50	700	950	1800	3000	4000	5'	3'	83.5	1200	6500	7500	94		1.20	1.40	1.75	3.11
TR 160 2_70	700	950	1800	3000	4000	5'	3'	83.5	1200	6500	7500	94		1.18	1.39	1.74	3.09
TR 160 2_100	350	660	1200	3000	4000	5'	3'	83.5	1200	6500	7500	94		1.18	1.38	1.73	3.09
TR 160 3_48	700	950	1800	2200	3500	7'	5'	60	1200	6500	7500	91		4.10	4.31	4.66	6.01
TR 160 3_64	700	950	1800	2200	3500	7'	5'	60	1200	6500	7500	91		3.90	4.11	4.46	5.81
TR 160 3_75	700	950	1800	2500	3500	7'	5'	60	1200	6500	7500	91		2.91	3.11	3.46	4.82
TR 160 3_80	700	950	1800	2200	3500	7'	5'	60	1200	6500	7500	91		3.90	4.11	4.46	5.81
TR 160 3_84	700	950	1800	3000	4000	7'	5'	60	1200	6500	7500	91		1.84	2.05	2.40	3.75
TR 160 3_90	350	660	1200	3000	4000	7'	5'	60	1200	6500	7500	91		1.24	1.45	1.80	3.15
TR 160 3_120	700	950	1800	3000	4000	7'	5'	60	1200	6500	7500	91		1.23	1.44	1.79	3.14
TR 160 3_125	700	950	1800	2500	3500	7'	5'	60	1200	6500	7500	91		2.74	2.95	3.30	4.65
TR 160 3_140	700	950	1800	3000	4000	7'	5'	60	1200	6500	7500	91		1.78	1.98	2.33	3.69
TR 160 3_150	700	950	1800	3000	4000	7'	5'	60	1200	6500	7500	91		1.23	1.44	1.79	3.14
TR 160 3_160	700	950	1800	3000	4000	7'	5'	60	1200	6500	7500	91		1.20	1.41	1.76	3.11
TR 160 3_175	700	950	1800	3000	4000	7'	5'	60	1200	6500	7500	91		1.76	1.96	2.31	3.67
TR 160 3_200	700	950	1800	3000	4000	7'	5'	60	1200	6500	7500	91		1.20	1.41	1.76	3.11
TR 160 3_210	700	950	1800	3000	4000	7'	5'	60	1200	6500	7500	91		1.23	1.44	1.79	3.14
TR 160 3_250	700	950	1800	3000	4000	7'	5'	60	1200	6500	7500	91		1.19	1.40	1.75	3.10
TR 160 3_280	700	950	1800	3000	4000	7'	5'	60	1200	6500	7500	91		1.18	1.39	1.74	3.09
TR 160 3_350	700	950	1800	3000	4000	7'	5'	60	1200	6500	7500	91		1.18	1.39	1.74	3.09
TR 160 3_400	700	950	1800	3000	4000	7'	5'	60	1200	6500	7500	91		1.18	1.38	1.73	3.09
TR 160 3_500	700	950	1800	3000	4000	7'	5'	60	1200	6500	7500	91		1.18	1.38	1.73	3.09
TR 160 3_700	700	950	1800	3000	4000	7'	5'	60	1200	6500	7500	91		1.18	1.38	1.73	3.09
TR 160 3_1000	350	660	1200	3000	4000	7'	5'	60	1200	6500	7500	91		1.18	1.38	1.73	3.09

TR



TR G 160

55A1 ... 180A1

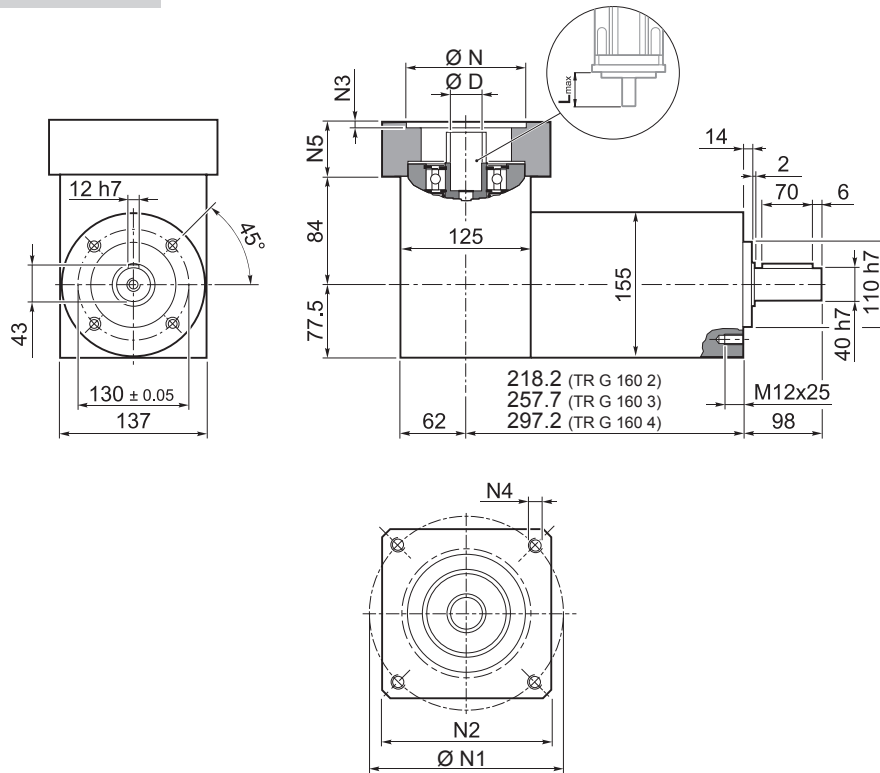

TR

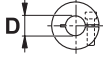
											N	N1	N2	N3	N4	N5	L _{max}
	14	15.875	16	19	-	-	-	-	-	-							
55A1	14	15.875	16	19	-	-	-	-	-	-	55.5	125.7	140	5	M6x15	39.5	50
80A2	14	15.875	16	19	-	-	-	-	-	-	80	100	140	5	M6x15	39.5	50
95A1	14	15.875	16	19	22	24	-	-	-	-	95	115	140	5	M8x20	39.5	50
110A1	14	15.875	16	19	22	24	-	-	-	-	110	130	140	5	M8x20	39.5	50
110B1	14	15.875	16	19	22	24	-	-	-	-	110	145	140	6.5	M8x20	49.5	60
114A	14	15.875	16	19	22	24	28	32	35	38	114.3	200	170	6.5	M12x25	69.5	80
130A	14	15.875	16	19	22	24	-	-	-	-	130	165	140	5	M10x20	39.5	50
130A1	14	15.875	16	19	22	24	28	32	-	-	130	165	140	5	M10x20	49.5	60
180A	14	15.875	16	19	22	24	28	32	-	-	180	215	190	6.5	M14x25	49.5	60
180A1	14	15.875	16	19	22	24	28	32	35	38	180	215	190	6.5	M14x25	69.5	80

Für weitere Motoradapter und Antriebswellenbohrungen bitte nachfragen.

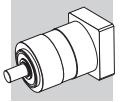

TR G 160

FM

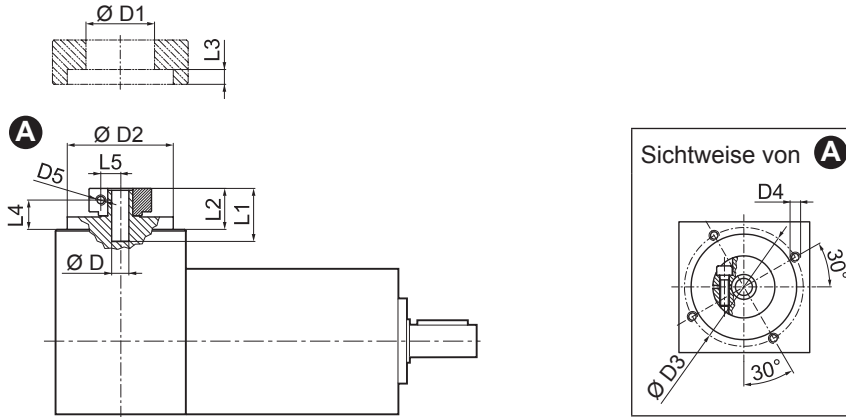

D			D1	D2	D3	D4	D5	L1	L2	L3	L4	L5
14	15.875	16	48	113	125.5	M8x15	M6	40	27.5	6	20	14.5
19			51	113	125.5	M8x15	M6	40	27.5	6	20	16.5
22	24		56.5	113	125.5	M8x15	M6	41	28.5	6	19.5	19
28			67	113	125.5	M8x15	M8	41	28.5	6	19.5	22.5
32			71	113	125.5	M8x15	M8	41	28.5	6	19.5	24.5
35			73	113	125.5	M8x15	M8	50	37.5	11.25	26	26
38			77.5	113	125.5	M8x15	M8	50	37.5	11.25	26	28

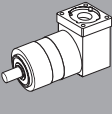
 i	M _{n 2}	M _{a 2}	M _{p 2}	n ₁	n _{1 max}	φ _S	φ _R	C _t	R _{2 max}	A _{2 max}	η	J _G [kgcm ²]			
	[Nm]	[Nm]	[Nm]	[min ⁻¹]	[min ⁻¹]	[arcmin]		[Nm/arcmin]	[N]	[N]	%	14 ... 19	22 - 24	28 - 32	35 - 38
TR G 160 2_3	350	660	1200	1900	3000	5'	3'	90	6500	7500	94	10.23	10.42	10.80	13.51
TR G 160 2_4	500	750	1400	2200	3500	5'	3'	90	6500	7500	94	6.52	6.71	7.09	9.80
TR G 160 2_5	500	750	1400	2500	3500	5'	3'	90	6500	7500	94	5.87	6.06	6.45	9.16
TR G 160 2_6	500	750	1400	2500	3500	5'	3'	90	6500	7500	94	4.58	4.77	5.16	7.86
TR G 160 2_7	500	750	1400	3000	4000	5'	3'	90	6500	7500	94	5.29	5.48	5.87	8.57
TR G 160 2_10	350	660	1200	3000	4000	5'	3'	90	6500	7500	94	4.97	5.16	5.54	8.25
TR G 160 3_9	350	660	1200	1900	3000	5'	3'	83.5	6500	7500	91	9.35	9.54	9.92	12.63
TR G 160 3_12	700	950	1800	1900	3000	5'	3'	83.5	6500	7500	91	8.78	8.97	9.36	12.07
TR G 160 3_15	700	950	1800	1900	3000	5'	3'	83.5	6500	7500	91	8.71	8.90	9.29	11.99
TR G 160 3_16	700	950	1800	2200	3500	5'	3'	83.5	6500	7500	91	5.79	5.98	6.36	9.07
TR G 160 3_20	700	950	1800	2500	3500	5'	3'	83.5	6500	7500	91	5.41	6.20	6.59	9.30
TR G 160 3_25	700	950	1800	2500	3500	5'	3'	83.5	6500	7500	91	5.95	5.54	5.93	8.64
TR G 160 3_28	700	950	1800	3000	4000	5'	3'	83.5	6500	7500	91	5.05	5.24	5.63	8.33
TR G 160 3_30	350	660	1200	3000	4000	5'	3'	83.5	6500	7500	91	4.89	5.09	5.47	8.18
TR G 160 3_35	700	950	1800	3000	4000	5'	3'	83.5	6500	7500	91	5.36	5.54	5.93	8.64
TR G 160 3_36	500	750	1400	2500	3500	5'	3'	83.5	6500	7500	91	4.32	4.51	4.90	7.60
TR G 160 3_40	700	950	1800	3000	4000	5'	3'	83.5	6500	7500	91	5.00	5.19	5.58	8.28
TR G 160 3_50	700	950	1800	3000	4000	5'	3'	83.5	6500	7500	91	4.99	5.18	5.56	8.27
TR G 160 3_70	700	950	1800	3000	4000	5'	3'	83.5	6500	7500	91	4.82	5.02	5.40	8.11
TR G 160 3_100	350	660	1200	3000	4000	5'	3'	83.5	6500	7500	91	4.82	5.01	5.39	8.10
TR G 160 4_48	700	950	1800	2200	3500	7'	5'	60	6500	7500	89	5.94	6.13	6.53	9.22
TR G 160 4_64	700	950	1800	2200	3500	7'	5'	60	6500	7500	89	5.74	5.93	6.31	9.02
TR G 160 4_75	700	950	1800	2500	3500	7'	5'	60	6500	7500	89	5.50	5.68	6.07	8.79
TR G 160 4_80	700	950	1800	2200	3500	7'	5'	60	6500	7500	89	5.74	5.93	6.31	9.02
TR G 160 4_84	700	950	1800	3000	4000	7'	5'	60	6500	7500	89	5.10	5.29	5.68	8.38
TR G 160 4_90	350	660	1200	3000	4000	7'	5'	60	6500	7500	89	4.88	5.08	5.46	8.17
TR G 160 4_120	700	950	1800	3000	4000	7'	5'	60	6500	7500	89	4.87	5.07	5.45	8.16
TR G 160 4_125	700	950	1800	2500	3500	7'	5'	60	6500	7500	89	5.33	5.52	5.91	8.62
TR G 160 4_140	700	950	1800	3000	4000	7'	5'	60	6500	7500	89	5.04	5.22	5.61	8.32
TR G 160 4_150	700	950	1800	3000	4000	7'	5'	60	6500	7500	89	4.87	5.07	5.45	8.16
TR G 160 4_160	700	950	1800	3000	4000	7'	5'	60	6500	7500	89	4.84	5.04	5.42	8.13
TR G 160 4_175	700	950	1800	3000	4000	7'	5'	60	6500	7500	89	5.02	5.20	5.59	8.30
TR G 160 4_200	700	950	1800	3000	4000	7'	5'	60	6500	7500	89	4.84	5.04	5.42	8.13
TR G 160 4_210	700	950	1800	3000	4000	7'	5'	60	6500	7500	89	4.87	5.07	5.45	8.16
TR G 160 4_250	700	950	1800	3000	4000	7'	5'	60	6500	7500	89	4.83	5.03	5.41	8.12
TR G 160 4_280	700	950	1800	3000	4000	7'	5'	60	6500	7500	89	4.82	5.02	5.40	8.11
TR G 160 4_350	700	950	1800	3000	4000	7'	5'	60	6500	7500	89	4.82	2.05	5.40	8.11
TR G 160 4_400	700	950	1800	3000	4000	7'	5'	60	6500	7500	89	4.82	5.01	5.39	8.11
TR G 160 4_500	700	950	1800	3000	4000	7'	5'	60	6500	7500	89	4.82	5.01	5.39	8.11
TR G 160 4_700	700	950	1800	3000	4000	7'	5'	60	6500	7500	89	4.82	5.01	5.39	8.11
TR G 160 4_1000	350	660	1200	3000	4000	7'	5'	60	6500	7500	89	4.82	5.01	5.39	8.11

TR



TR MB 160

55A1 ... 180A1

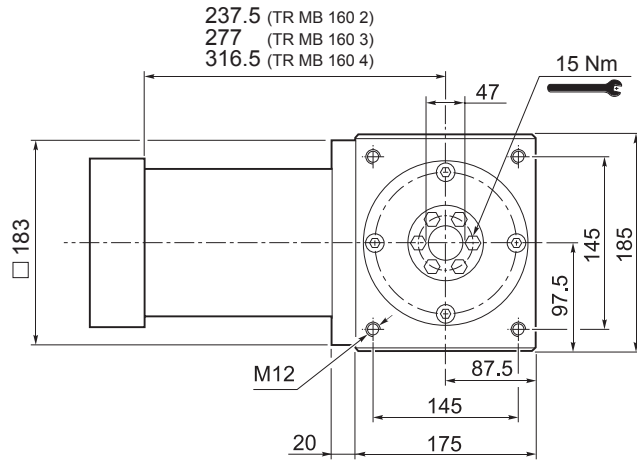
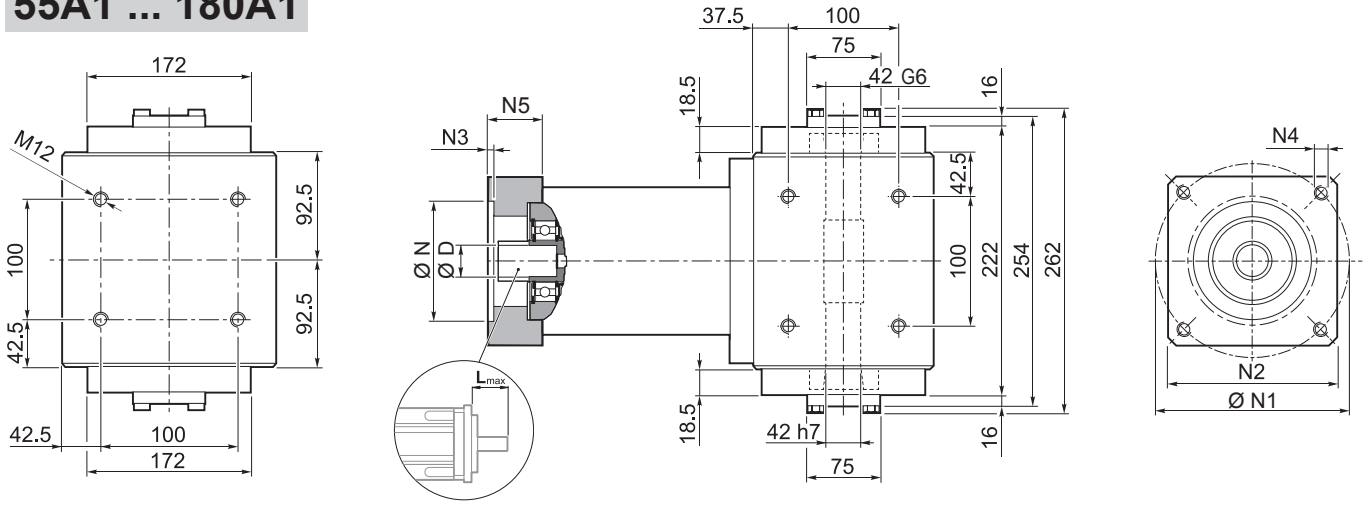

TR MB 160 2	59
TR MB 160 3	63.5
TR MB 160 4	70.5

											N	N1	N2	N3	N4	N5	L _{max}
	14	15.875	16	19	-	-	-	-	-	-							
55A1	14	15.875	16	19	-	-	-	-	-	-	55.5	125.7	140	5	M6x15	39.5	50
80A2	14	15.875	16	19	-	-	-	-	-	-	80	100	140	5	M6x15	39.5	50
95A1	14	15.875	16	19	22	24	-	-	-	-	95	115	140	5	M8x20	39.5	50
110A1	14	15.875	16	19	22	24	-	-	-	-	110	130	140	5	M8x20	39.5	50
110B1	14	15.875	16	19	22	24	-	-	-	-	110	145	140	6.5	M8x20	49.5	60
114A	14	15.875	16	19	22	24	28	32	35	38	114.3	200	170	6.5	M12x25	69.5	80
130A	14	15.875	16	19	22	24	-	-	-	-	130	165	140	5	M10x20	39.5	50
130A1	14	15.875	16	19	22	24	28	32	-	-	130	165	140	5	M10x20	49.5	60
180A	14	15.875	16	19	22	24	28	32	-	-	180	215	190	6.5	M14x25	49.5	60
180A1	14	15.875	16	19	22	24	28	32	35	38	180	215	190	6.5	M14x25	69.5	80

Für weitere Motoradapter und Antriebswellenbohrungen bitte nachfragen.

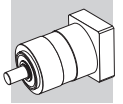

TR MB 160

FM

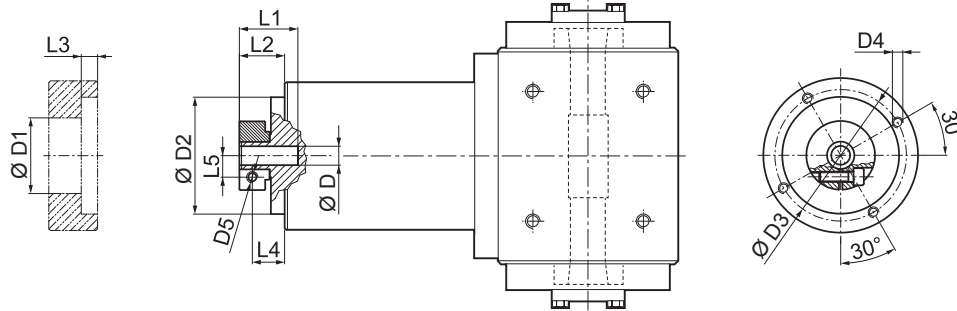

		D1	D2	D3	D4	D5	L1	L2	L3	L4	L5
14	15.875	48	130	142.5	M8x16	M6	40	27.5	6	20	14.5
19		51	130	142.5	M8x16	M6	40	27.5	6	20	16.5
22	24	56.5	130	142.5	M8x16	M6	41	28.5	6	19.5	19
28		67	130	142.5	M8x16	M8	41	28.5	6	19.5	22.5
32		71	130	142.5	M8x16	M8	41	28.5	6	19.5	24.5
35		73	130	142.5	M8x16	M8	50	37.5	11.25	26	26
38		77.5	130	142.5	M8x16	M8	50	37.5	11.25	26	28

	i	M _{n2} [Nm]	M _{a2} [Nm]	M _{p2} [Nm]	n ₁ [min ⁻¹]	n _{1 max} [min ⁻¹]	φ _S [arcmin]	φ _R [arcmin]	C _t [Nm/arcmin]	η %	J _G [kgm ²]			
											D	14 ... 19	22 - 24	28 - 32
TR MB 160 2_3		350	660	1200	1900	3000	5'	3'	90	94	8.39	8.60	8.95	10.30
TR MB 160 2_4		500	750	1400	2200	3500	5'	3'	90	94	4.68	4.89	5.24	6.59
TR MB 160 2_5		500	750	1400	2500	3500	5'	3'	90	94	3.28	3.49	3.84	5.19
TR MB 160 2_6		500	750	1400	2500	3500	5'	3'	90	94	1.32	1.53	1.88	3.23
TR MB 160 2_7		500	750	1400	3000	4000	5'	3'	90	94	2.03	2.24	2.59	3.94
TR MB 160 2_10		350	660	1200	3000	4000	5'	3'	90	94	1.33	1.53	1.88	3.24
TR MB 160 3_9		350	660	1200	1900	3000	5'	3'	83	91	7.51	7.72	8.07	9.42
TR MB 160 3_12		700	950	1800	1900	3000	5'	3'	83	91	7.10	7.30	7.65	9.01
TR MB 160 3_15		700	950	1800	1900	3000	5'	3'	83	91	6.94	7.15	7.50	8.85
TR MB 160 3_16		700	950	1800	2200	3500	5'	3'	83	91	3.95	4.16	4.51	5.86
TR MB 160 3_20		700	950	1800	2500	3500	5'	3'	83	91	2.82	3.02	3.37	4.73
TR MB 160 3_25		700	950	1800	2500	3500	5'	3'	83	91	2.76	2.97	3.32	4.67
TR MB 160 3_28		700	950	1800	3000	4000	5'	3'	83	91	1.79	2.00	2.35	3.70
TR MB 160 3_30		350	660	1200	3000	4000	5'	3'	83	91	1.25	1.46	1.81	3.16
TR MB 160 3_35		700	950	1800	3000	4000	5'	3'	83	91	1.77	1.97	2.32	3.68
TR MB 160 3_36		500	750	1400	2500	3500	5'	3'	83	91	1.06	1.27	1.62	2.97
TR MB 160 3_40		700	950	1800	3000	4000	5'	3'	83	91	1.21	1.42	1.77	3.12
TR MB 160 3_50		700	950	1800	3000	4000	5'	3'	83	91	1.20	1.40	1.75	3.11
TR MB 160 3_70		700	950	1800	3000	4000	5'	3'	83	91	1.18	1.39	1.74	3.09
TR MB 160 3_100		350	660	1200	3000	4000	5'	3'	83	91	1.18	1.38	1.73	3.09
TR MB 160 4_48		700	950	1800	2200	3500	7'	5'	60	89	4.10	4.31	4.66	6.01
TR MB 160 4_64		700	950	1800	2200	3500	7'	5'	60	89	3.90	4.11	4.46	5.81
TR MB 160 4_75		700	950	1800	2500	3500	7'	5'	60	89	2.91	3.11	3.46	4.82
TR MB 160 4_80		700	950	1800	2200	3500	7'	5'	60	89	3.90	4.11	4.46	5.81
TR MB 160 4_84		700	950	1800	3000	4000	7'	5'	60	89	1.84	2.05	2.40	3.75
TR MB 160 4_90		350	660	1200	3000	4000	7'	5'	60	89	1.24	1.45	1.80	3.15
TR MB 160 4_120		700	950	1800	3000	4000	7'	5'	60	89	1.23	1.44	1.79	3.14
TR MB 160 4_125		700	950	1800	2500	3500	7'	5'	60	89	2.74	2.95	3.30	4.65
TR MB 160 4_140		700	950	1800	3000	4000	7'	5'	60	89	1.78	1.98	2.33	3.69
TR MB 160 4_150		700	950	1800	3000	4000	7'	5'	60	89	1.23	1.44	1.79	3.14
TR MB 160 4_160		700	950	1800	3000	4000	7'	5'	60	89	1.20	1.41	1.76	3.11
TR MB 160 4_175		700	950	1800	3000	4000	7'	5'	60	89	1.76	1.96	2.31	3.67
TR MB 160 4_200		700	950	1800	3000	4000	7'	5'	60	89	1.20	1.41	1.76	3.11
TR MB 160 4_210		700	950	1800	3000	4000	7'	5'	60	89	1.23	1.44	1.79	3.14
TR MB 160 4_250		700	950	1800	3000	4000	7'	5'	60	89	1.19	1.40	1.75	3.10
TR MB 160 4_280		700	950	1800	3000	4000	7'	5'	60	89	1.18	1.39	1.74	3.09
TR MB 160 4_350		700	950	1800	3000	4000	7'	5'	60	89	1.18	1.39	1.74	3.09
TR MB 160 4_400		700	950	1800	3000	4000	7'	5'	60	89	1.18	1.38	1.73	3.09
TR MB 160 4_500		700	950	1800	3000	4000	7'	5'	60	89	1.18	1.38	1.73	3.09
TR MB 160 4_700		700	950	1800	3000	4000	7'	5'	60	89	1.18	1.38	1.73	3.09
TR MB 160 4_1000		350	660	1200	3000	4000	7'	5'	60	89	1.18	1.38	1.73	3.09

TR

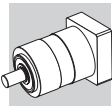

TR 190

55A1 ... 180A1

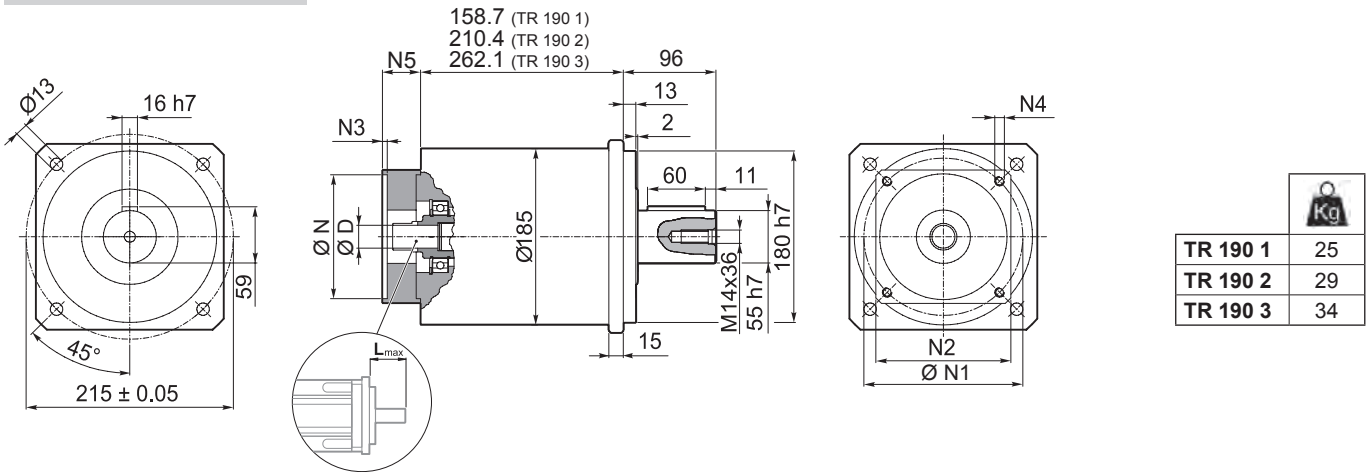

TR

	D												N	N1	N2	N3	N4	N5	L _{max}	
55A1	14	16	19	-	-	-	-	-	-	-	-	-	-	55.5	125.7	140	5	M6x15	39.5	50
80A2	14	16	19	-	-	-	-	-	-	-	-	-	-	80	100	140	5	M6x15	39.5	50
95A1	14	16	19	22	24	-	-	-	-	-	-	-	-	95	115	140	5	M8x20	39.5	50
110A1	14	16	19	22	24	-	-	-	-	-	-	-	-	110	130	140	5	M8x20	39.5	50
110B1	14	16	19	22	24	-	-	-	-	-	-	-	-	110	145	140	6.5	M8x20	49.5	60
114A	14	16	19	22	24	28	32	35	38	42	45	48	-	114.3	200	170	6.5	M12x25	69.5	80
130A	14	16	19	22	24	-	-	-	-	-	-	-	-	130	165	140	5	M10x20	39.5	50
130A1	14	16	19	22	24	28	32	-	-	-	-	-	-	130	165	140	5	M10x20	49.5	60
180A	14	16	19	22	24	28	32	-	-	-	-	-	-	180	215	190	6.5	M14x25	49.5	60
180A1	14	16	19	22	24	28	32	35	38	42	45	48	-	180	215	190	6.5	M14x25	69.5	80

Für weitere Motoradapter und Antriebswellenbohrungen bitte nachfragen.

FM

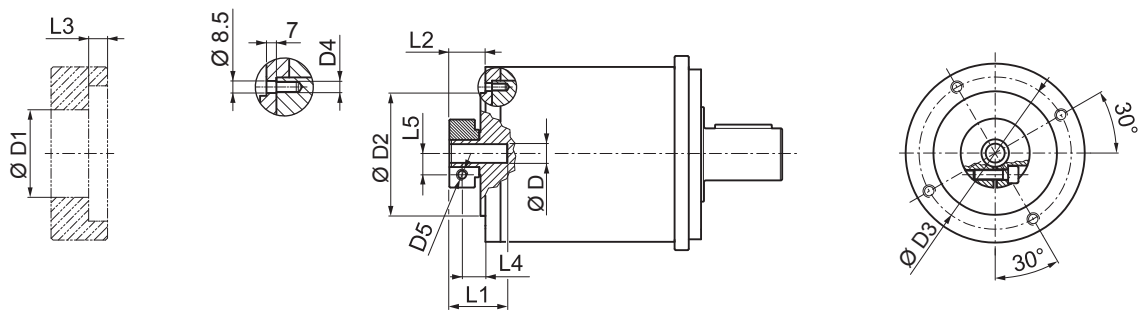

D	D1	D2	D3	D4	D5	L1	L2	L3	L4	L5
14 16	48	130	142.5	M8x14	M6	45.5	27.5	6	20	14.5
19	51	130	142.5	M8x14	M6	45.5	27.5	6	20	16.5
22 24	56.5	130	142.5	M8x14	M6	47	29	6	20	19
28	67	130	142.5	M8x14	M8	47	29	6	20	22.5
32	71	130	142.5	M8x14	M8	47	29	6	20	24.5
35	73	130	142.5	M8x14	M8	54.5	36.5	6	25	26
38	77.5	130	142.5	M8x14	M8	54.5	36.5	6	25	28
42	92	130	142.5	M8x14	M10	60.5	40	6	25	33
45	95	130	142.5	M8x14	M10	60.5	40	6	25	33
48	97	130	142.5	M8x14	M10	60.5	40	6	25	33

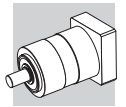

TR 190

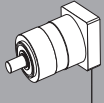
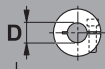
 <i>i</i>	$M_{n 2}$	$M_{a 2}$	$M_{p 2}$	n_1	$n_{1 \text{ max}}$	φ_S	φ_R	C_t	$R_{2 \text{ max}}$	$A_{2 \text{ max}}$	η	J_G [kgcm ²]				
	[Nm]	[Nm]	[Nm]	[min ⁻¹]	[min ⁻¹]	[arcmin]		$\left[\frac{Nm}{arcmin} \right]$	[N]	[N]	%					
												14 ... 24	28 - 32	35 - 35	42	45 - 48
TR 190 1_3	500	800	1400	1500	2500	5'	3'	130	14000	15000	97	24.20	24.88	25.65	29.30	29.90
TR 190 1_4	700	950	1800	2100	3000	5'	3'	130	14000	15000	97	13.41	14.09	14.85	18.51	19.11
TR 190 1_5	700	950	1800	2300	3000	5'	3'	130	14000	15000	97	9.32	10.00	10.77	14.42	15.02
TR 190 1_6	700	950	1800	2300	3000	5'	3'	130	14000	15000	97	2.88	3.56	4.33	7.98	8.58
TR 190 1_7	700	950	1800	2900	3500	5'	3'	130	14000	15000	97	5.68	6.36	7.13	10.78	11.38
TR 190 1_10	500	800	1400	2900	3500	5'	3'	130	14000	15000	97	3.57	4.25	5.02	8.67	9.27
TR 190 2_9	500	800	1400	1500	2500	5'	3'	100	14000	15000	94	23.23	23.91	24.67	28.33	28.93
TR 190 2_12	1000	1200	2200	1500	2500	5'	3'	100	14000	15000	94	22.03	22.71	23.48	27.13	27.73
TR 190 2_15	1000	1200	2200	1500	2500	5'	3'	100	14000	15000	94	21.58	22.25	23.02	26.68	27.27
TR 190 2_16	1000	1200	2200	2100	3000	5'	3'	100	14000	15000	94	12.19	12.86	13.63	17.29	17.89
TR 190 2_20	1000	1200	2200	2300	3000	5'	3'	100	14000	15000	94	8.54	9.22	9.98	13.64	14.24
TR 190 2_25	1000	1200	2200	2300	3000	5'	3'	100	14000	15000	94	8.37	9.05	9.82	13.48	14.07
TR 190 2_28	1000	1200	2200	2900	3500	5'	3'	100	14000	15000	94	5.28	5.96	6.73	10.38	10.98
TR 190 2_30	500	800	1400	2900	3500	5'	3'	100	14000	15000	94	3.48	4.16	4.93	8.58	9.18
TR 190 2_35	1000	1200	2200	2900	3500	5'	3'	100	14000	15000	94	5.20	5.87	6.64	10.30	10.90
TR 190 2_36	700	950	1800	2300	3000	5'	3'	100	14000	15000	94	2.18	2.86	3.63	7.28	7.88
TR 190 2_40	1000	1200	2200	2900	3500	5'	3'	100	14000	15000	94	3.37	4.05	4.82	8.48	9.07
TR 190 2_50	1000	1200	2200	2900	3500	5'	3'	100	14000	15000	94	3.33	4.01	4.78	8.44	9.03
TR 190 2_70	1000	1200	2200	2900	3500	5'	3'	100	14000	15000	94	3.30	3.97	4.74	8.40	9.00
TR 190 2_100	500	800	1400	2900	3500	5'	3'	100	14000	15000	94	3.28	3.95	4.72	8.38	8.98
TR 190 3_48	1000	1200	2200	2100	3000	7'	5'	90	14000	15000	91	12.73	13.40	14.17	17.83	18.43
TR 190 3_64	1000	1200	2200	2100	3000	7'	5'	90	14000	15000	91	12.10	12.78	13.55	17.21	17.80
TR 190 3_75	1000	1200	2200	2300	3000	7'	5'	90	14000	15000	91	8.86	9.54	10.31	13.97	14.56
TR 190 3_80	1000	1200	2200	2100	3000	7'	5'	90	14000	15000	91	12.09	12.76	13.53	17.19	17.79
TR 190 3_84	1000	1200	2200	2900	3500	7'	5'	90	14000	15000	91	5.46	6.13	6.90	10.56	11.16
TR 190 3_90	500	800	1400	2900	3500	7'	5'	90	14000	15000	91	3.47	4.15	4.92	8.57	9.17
TR 190 3_120	1000	1200	2200	2900	3500	7'	5'	90	14000	15000	91	3.46	4.14	4.91	8.56	9.16
TR 190 3_125	1000	1200	2200	2300	3000	7'	5'	90	14000	15000	91	8.34	9.01	9.78	13.44	14.04
TR 190 3_140	1000	1200	2200	2900	3500	7'	5'	90	14000	15000	91	5.25	5.92	6.69	10.35	10.95
TR 190 3_150	1000	1200	2200	2900	3500	7'	5'	90	14000	15000	91	3.46	4.13	4.90	8.56	9.15
TR 190 3_160	1000	1200	2200	2900	3500	7'	5'	90	14000	15000	91	3.36	4.04	4.81	8.46	9.06
TR 190 3_175	1000	1200	2200	2900	3500	7'	5'	90	14000	15000	91	5.18	5.85	6.62	10.28	10.88
TR 190 3_200	1000	1200	2200	2900	3500	7'	5'	90	14000	15000	91	3.36	4.03	4.80	8.46	9.06
TR 190 3_210	1000	1200	2200	2900	3500	7'	5'	90	14000	15000	91	3.45	4.13	4.90	8.55	9.15
TR 190 3_250	1000	1200	2200	2900	3500	7'	5'	90	14000	15000	91	3.32	4.00	4.77	8.42	9.02
TR 190 3_280	1000	1200	2200	2900	3500	7'	5'	90	14000	15000	91	3.29	3.97	4.74	8.39	8.99
TR 190 3_350	1000	1200	2200	2900	3500	7'	5'	90	14000	15000	91	3.29	3.97	4.74	8.39	8.99
TR 190 3_400	1000	1200	2200	2900	3500	7'	5'	90	14000	15000	91	3.27	3.95	4.72	8.38	8.97
TR 190 3_500	1000	1200	2200	2900	3500	7'	5'	90	14000	15000	91	3.27	3.95	4.72	8.38	8.97
TR 190 3_700	1000	1200	2200	2900	3500	7'	5'	90	14000	15000	91	3.27	3.95	4.72	8.38	8.97
TR 190 3_1000	500	800	1400	2900	3500	7'	5'	90	14000	15000	91	3.27	3.95	4.72	8.38	8.97

TR



5.3.1 MASCHINENWELLE

Für die Welle der angetriebenen Maschine ist eine hochwertige Stahllegierung zu bevorzugen. Die Tabelle unten zeigt die empfohlenen Abmessungen, die vom Kunden bei der Konstruktion der Gegenwelle zu berücksichtigen sind. Weiterhin wird eine axiale Aufnahmevorrichtung für die Welle empfohlen (nicht gezeigt).

Anzahl und Größe der entsprechenden Gewindebohrungen am Wellenende sind von den Anwendungsanforderungen abhängig.

MB

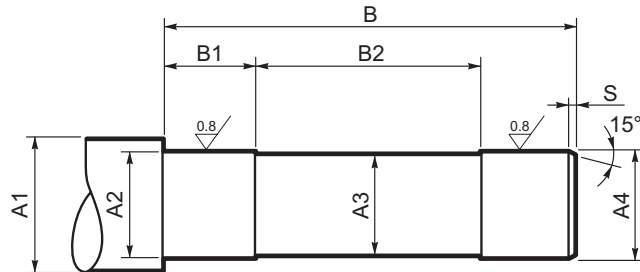

TR

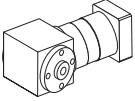
	A1	A2	A3	A4	B	B1	B2	S
TR MB 080	≥ 25	20 h7	18	20 h7	178	50	90	1
TR MB 105	≥ 40	32 h7	30	32 h7	205	60	115	
TR MB 130/160	≥ 50	42 h7	40	42 h7	259	70	140	

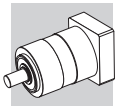

MP PRÄZISIONSPLANETENGETRIEBE

MP-Präzisionsplanetengetriebe bestehen durch optimale Leistungsfähigkeit und herausragende Zuverlässigkeit.

Sie sind in verschiedenen Konfigurationen (Antrieb rechtwinklig, Abtrieb rechtwinklig, Hohlwelle, Eingangsvollwelle) und Motoradaptern erhältlich und so mit den mechanischen Schnittstellen der marktgängigsten Servomotoren kompatibel.

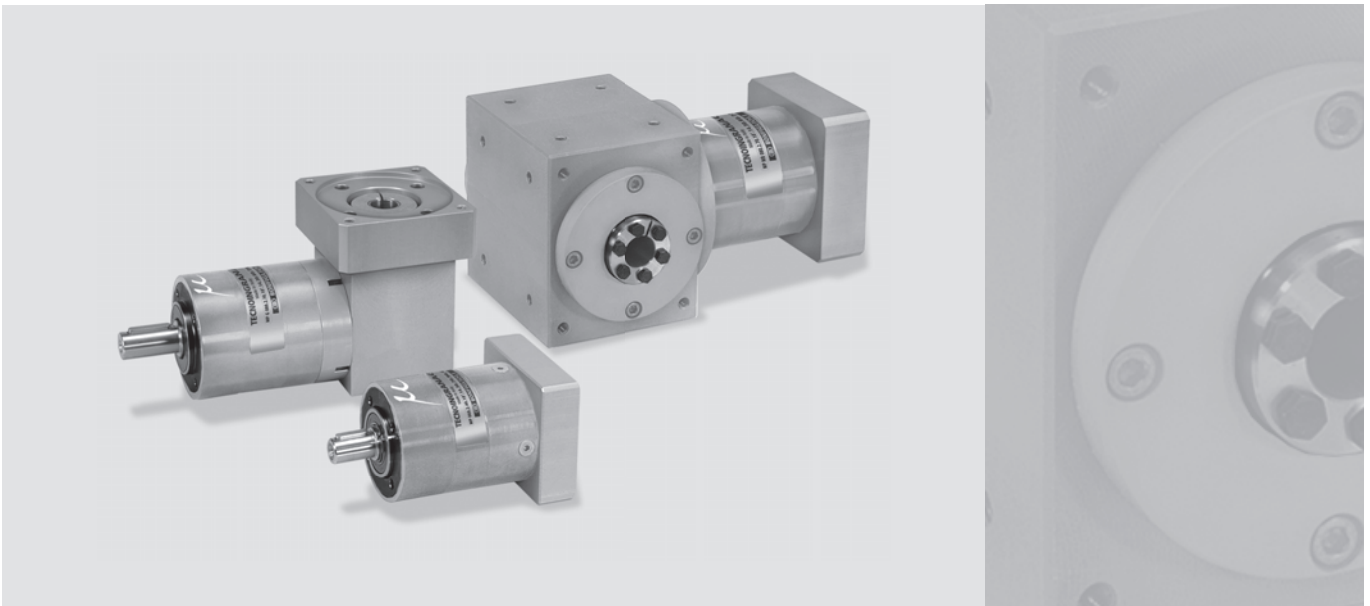

MP

Produktmerkmale:

- Hohe Drehmomentdichte
- Hohes Beschleunigungs- und Nenndrehmoment
- Hohe radiale und axiale Belastbarkeit
- Entwickelt für Zyklus- und Dauerbetrieb
- Hohe Verdrehsteifigkeit
- Verdrehflankenspiels unter 10 arcmin
- Maximale Flexibilität (standard/reduziertes Flankenspiel; standard/verstärkte Lager)
- Verschiedene Varianten für Ihre Anforderungen.



6 MERKMALE DER MP-REIHE

Die Planetengetriebe der MP-Reihe zeichnen sich durch geringes Verdrehspiel, hohes übertragbares Drehmoment und hohe Getriebeübersetzungen aus.

Alle Getriebe sind laufruhig und gewährleisten eine lange und wartungsarme Nutzungsdauer. Die Motormontage ist einfach und erfordert keinerlei Spezialwerkzeug.

- Erhältlich entweder mit standard (STD) oder reduziertem (LOW) Flankenspiel:
 - 1-stufige Getriebe: standard $\varphi_s \leq 15'$; reduziert $\varphi_R \leq 10'$
 - 2-stufige Getriebe: standard $\varphi_s \leq 15'$; reduziert $\varphi_R \leq 10'$
 - 3-stufige Getriebe: (nur G und MB): standard $\varphi_R \leq 15'$; reduziert $\varphi_R \leq 10'$
 - 3-stufige Getriebe: standard $\varphi_s \leq 17'$; reduziert $\varphi_R \leq 12'$
 - 4-stufige Getriebe (nur G und MB): standard $\varphi_s \leq 17'$; reduziert $\varphi_R \leq 12'$
- Eine hohe IP-Schutzklasse (IP65) sorgt dafür, dass innenliegende Teile vor Staub- und Flüssigkeitseintritt geschützt sind.
- Serienmäßige Fluorelastomer-Wellendichtungen an der Eingangswelle.
- Schalldruckpegel $L_p \leq 70$ dB(A). Gemessen in 1 m Abstand ohne Last und bei einer Eingangsdrehzahl von $n_1 = 3000$ min⁻¹; $i=10$.
- Lager für eine durchschnittliche Lebensdauer von von 20.000 Stunden unter normalen Betriebsbedingungen geeignet. Die folgende Tabelle zeigt die Lagertypen für die Abtriebswelle.

	MP 053	MP 060	MP 080	MP 105	MP 130	MP 160	MP 190
SB							
HB							

MP

Max. Belastbarkeit der Abtriebswelle

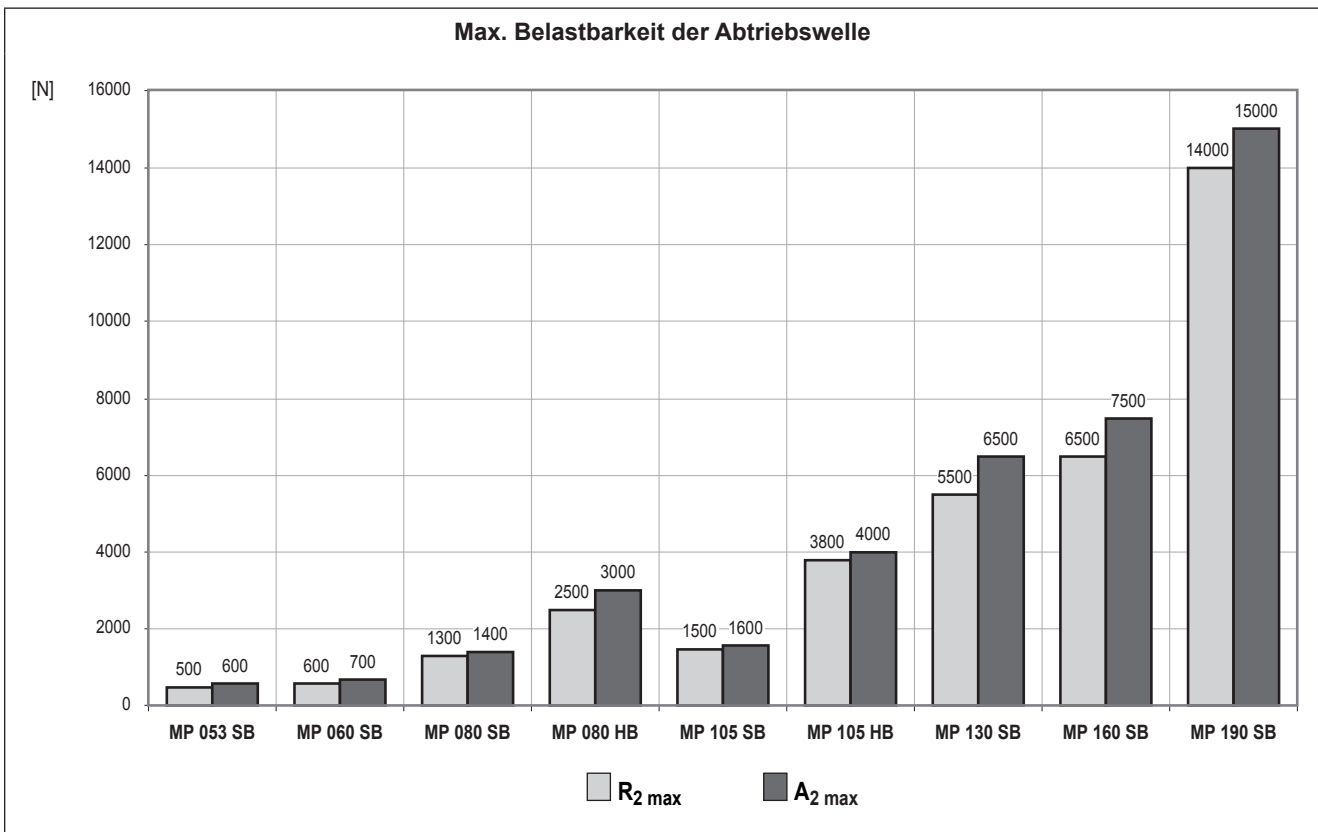

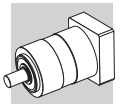

- Große Auswahl an Motoradaptern sorgt für den Anschluss an die marktgängigsten Servomotoren.

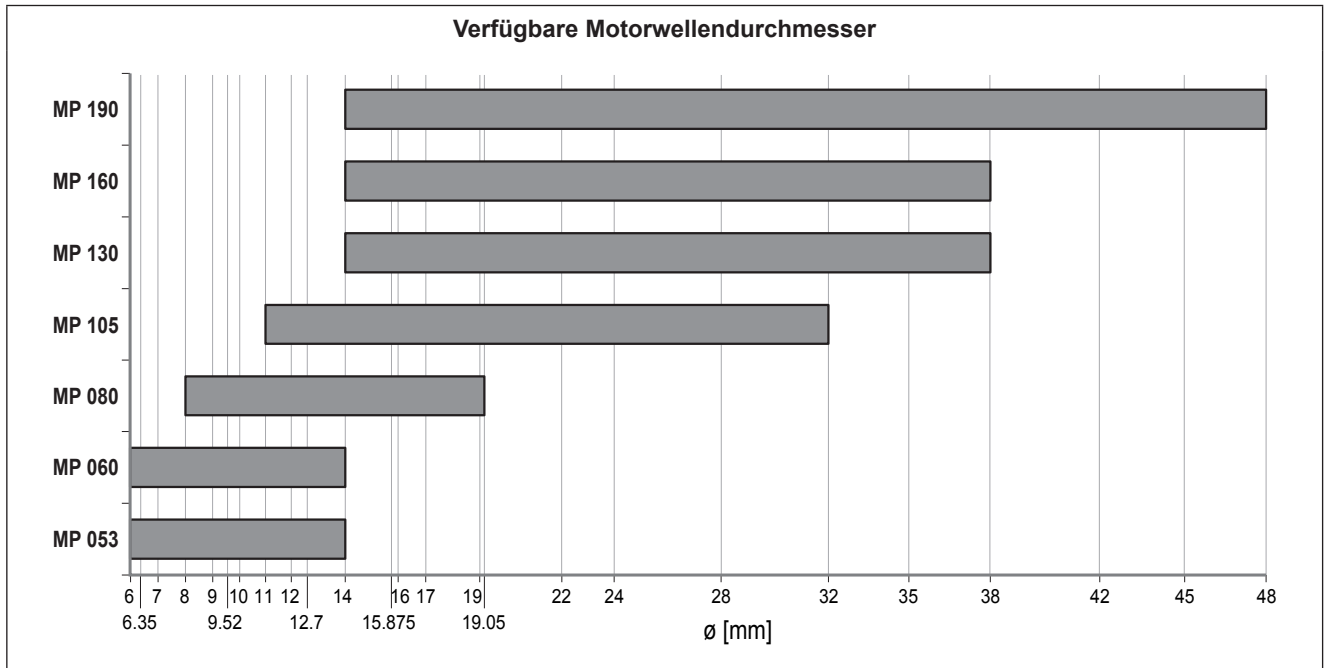

- Schmierung optimiert für die gewünschte Betriebsart.
Ohne Verunreinigung muss das Schmiermittel nicht regelmäßig gewechselt werden.

Betrieb	MP 053 - MP 060	MP 080 ... MP 190	andere Dichtungen
S1 (kontinuierlich)	NLGI Fettkonsistenz 00	Synthetiköl Viskositätsklasse ISO VG 220	Fluoroelastomer
S5 (unterbrochen)		NLGI Fettkonsistenz 00	NBR

- Umgebungstemperatur min. -20°C, max. +30°C; bei Temperaturen höher als 30°C ist der Temperaturfaktor f_T zu berücksichtigen.
- Die Gehäusetemperatur darf $T_{max} = 90°C$ nicht übersteigen.

Übersicht der Nenn Drehmomente M_{n2} [Nm]																													
	[1]	3	4	5	6	7	9	10	12	15	16	20	25	28	30	35	36	40	45	48	50	60	64	70	75	80	81	84	90
MP 053		12	15	15	15	15	12	-	20	20	20	20	20	20	-	20	15	-	20	20	-	20	20	-	20	20	12	20	-
MP 060		18	25	25	25	25	18	18	30	30	30	30	30	30	18	30	25	30	-	30	30	-	30	30	30	30	-	30	18
MP 080		40	50	50	50	50	40	40	70	70	70	70	70	70	40	70	50	70	-	70	70	-	70	70	70	70	-	70	40
MP 105		100	140	140	140	140	100	100	170	170	170	170	170	170	100	170	140	170	-	170	170	-	170	170	170	170	-	170	100
MP 130		215	380	380	380	380	215	215	450	450	450	450	450	450	215	450	380	450	-	450	450	-	450	450	450	450	-	450	215
MP 160		350	500	500	500	500	350	350	700	700	700	700	700	700	350	700	500	700	-	700	700	-	700	700	700	700	-	700	350
MP 190		500	700	700	700	700	500	500	1000	1000	1000	1000	1000	1000	500	1000	700	1000	-	1000	1000	-	1000	1000	1000	1000	-	1000	500
	[1]	100	112	120	125	140	144	150	160	175	180	200	210	216	225	245	250	252	280	324	350	400	405	500	567	700	729	1000	
MP 053		20	20	-	20	20	20	-	-	20	20	-	-	20	20	20	-	20	-	20	-	-	20	-	20	-	12	-	
MP 060		18	-	30	30	30	-	30	30	30	-	30	30	30	-	-	30	-	30	-	30	30	-	30	-	30	-	18	
MP 080		40	-	70	70	70	-	70	70	70	-	70	70	70	-	-	70	-	70	-	70	70	-	70	-	70	-	40	
MP 105		100	-	170	170	170	-	170	170	170	-	170	170	170	-	-	170	-	170	-	170	170	-	170	-	170	-	100	
MP 130		215	-	450	450	450	-	450	450	450	-	450	450	450	-	-	450	-	450	-	450	450	-	450	-	450	-	215	
MP 160		350	-	500	500	500	-	500	500	500	-	500	500	500	-	-	500	-	500	-	500	500	-	500	-	500	-	350	
MP 190		500	-	700	700	700	-	700	700	700	-	700	700	700	-	-	700	-	700	-	700	700	-	700	-	700	-	500	

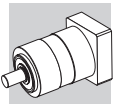

6.1 BESTELLBEZEICHNUNG

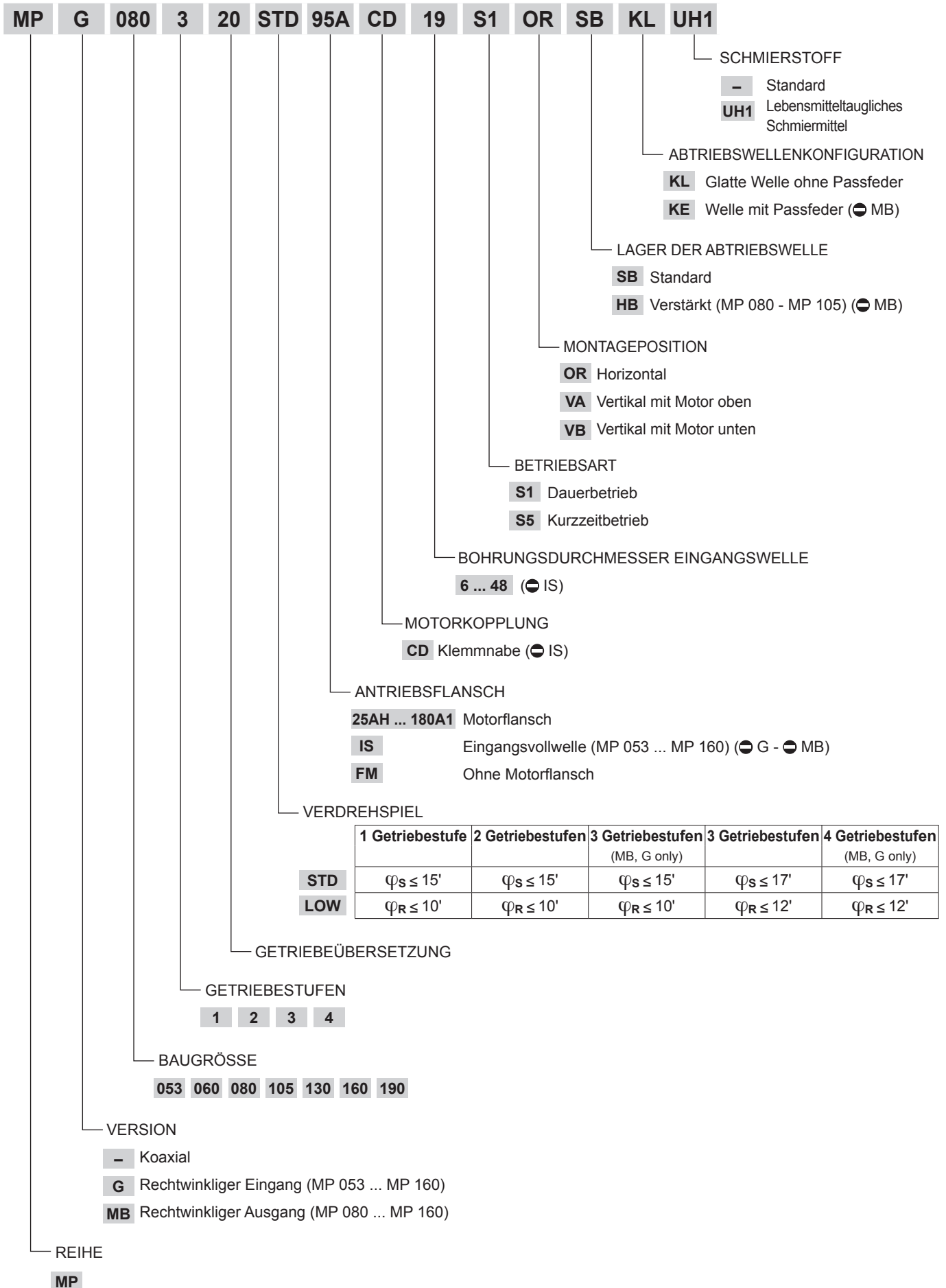

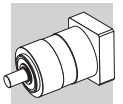

6.1.1 VERSIONEN UND ANTRIEBSSEITE

ANTRIEBSFLANSCH	VERSION	VERSION		
		Koaxial (—)	Rechtwinkliger Eingang (G)	Rechtwinkliger Ausgang (MB)
25AH ... 180A1				
IS			—	—
FM				

6.1.2 MONTAGEPOSITIONEN

	OR	VA	VB
—			
G			
MB			

MP

6.2 ZULÄSSIGE RADIAL- UND AXIALKRÄFTE BEI DER MB-VERSION

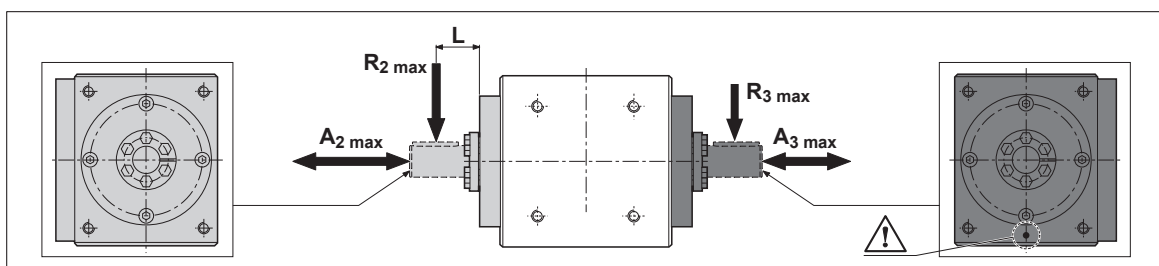

	R _{2 max} [N]	A _{2 max} [N]	L [mm]	R _{3 max} [N]	A _{3 max} [N]
MP MB 080	6000	5000	60	5500	5000
MP MB 105	9000	7500	80	7500	7500
MP MB 130	13500	11500	100	11000	11500
MP MB 160*	15000	11500	100	12500	11500

* Lager ausgelegt für eine durchschnittliche Lebensdauer von 10.000 Stunden unter normalen Betriebsbedingungen.



6.3 ABMESSUNGEN UND TECHNISCHE DATEN

MP 053

IS

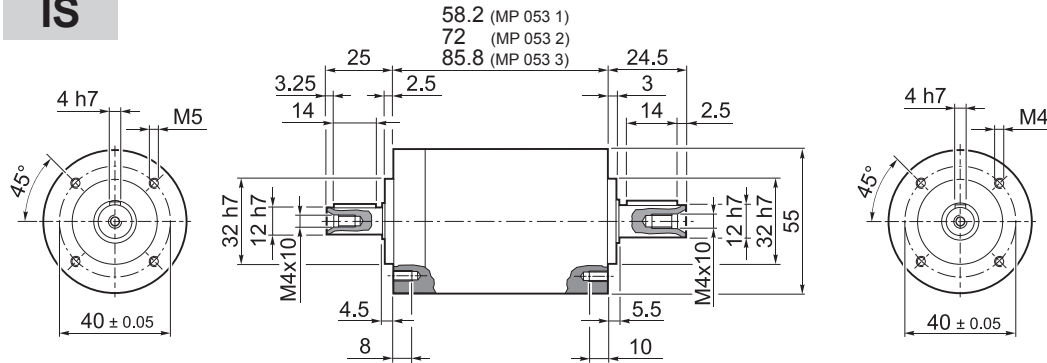

MP 053 1	0.8
MP 053 2	1.0
MP 053 3	1.3

25AH ... 80A

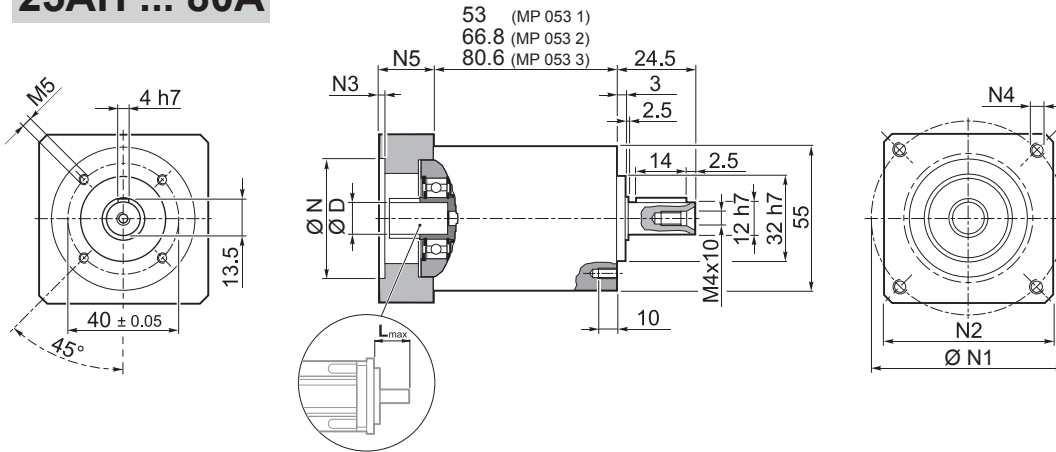

MP 053 1	0.8
MP 053 2	1.0
MP 053 3	1.3

												N	N1		N2	N3	N4	N5	Lmax
	min	max																	
25AH	6	6.35	7	8	9	9.52	-	-	-	-	-	25	36	48	55	3.5	4.5	25	25
26AH	6	6.35	7	8	9	9.52	-	-	-	-	-	26	36	48					
28AH	6	6.35	7	8	9	9.52	-	-	-	-	-	28	36	48					
30AH	6	6.35	7	8	9	9.52	-	-	-	-	-	30	36	48					
32AH	6	6.35	7	8	9	9.52	-	-	-	-	-	32	38	48					
34AH	6	6.35	7	8	9	9.52	-	-	-	-	-	34	40	48					
36AH	6	6.35	7	8	9	9.52	-	-	-	-	-	36	42	48					
38AH	6	6.35	7	8	9	9.52	-	-	-	-	-	38	44	48					
40AH	6	6.35	7	8	9	9.52	-	-	-	-	-	40	46	48					
38B	6	6.35	7	8	9	9.52	10	11	12	12.7	-	38.1	66.6		60	3	M4x10	18	25
40B	6	6.35	7	8	9	9.52	10	11	12	12.7	-	40	63		60	3	M4x10	18	25
50A	6	6.35	7	8	9	9.52	10	11	12	12.7	-	50	60		60	3	M4x10	18	25
50B	6	6.35	7	8	9	9.52	10	11	12	12.7	14	50	65		60	3	M5x12	23	30
50BH	6	6.35	7	8	9	9.52	10	11	12	12.7	14	50	65		60	4	5.5	23	30
50C	6	6.35	7	8	9	9.52	10	11	12	12.7	14	50	70		60	3	M4x10	23	30
50MH	6	6.35	7	8	9	9.52	10	11	12	12.7	-	50	65		55	2	5.5	16	23
60A	6	6.35	7	8	9	9.52	10	11	12	12.7	-	60	75		65	3	M5x12	18	25
60AH	6	6.35	7	8	9	9.52	10	11	12	12.7	-	60	75		65	3	5.5	18	25
60A1	6	6.35	7	8	9	9.52	10	11	12	12.7	14	60	75		65	3	M5x12	23	30
60AH1	6	6.35	7	8	9	9.52	10	11	12	12.7	14	60	75		65	3	5.5	23	30
60B	6	6.35	7	8	9	9.52	10	11	12	12.7	14	60	85		75	3	M5x12	23	30
60C	6	6.35	7	8	9	9.52	10	11	12	12.7	14	60	90		75	3	M5x12	23	30
70A	6	6.35	7	8	9	9.52	10	11	12	12.7	14	70	85		75	3	M6x15	23	30
70B	6	6.35	7	8	9	9.52	10	11	12	12.7	14	70	90		75	3	M5x12	23	30
73A	6	6.35	7	8	9	9.52	10	11	12	12.7	14	73	98.4		85	3	M5x12	25	32
80A	6	6.35	7	8	9	9.52	10	11	12	12.7	14	80	100		85	3	M6x15	23	30

Für weitere Motoradapter und Antriebswellenbohrungen bitte nachfragen.

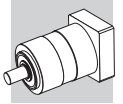

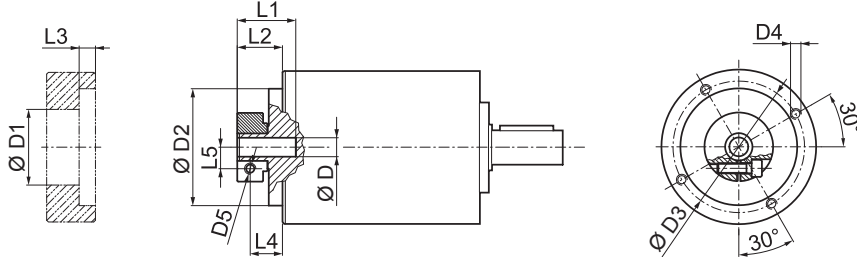

MP 053

FM

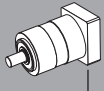

				D1	D2	D3	D4	D5	L1	L2	L3	L4	L5
6	6.35	7		32.5	50	42.5	M4x8	M4	20.2	13.2	3	8.7	8
8	9	9.52	10	32.5	50	42.5	M4x8	M4	20.2	13.2	3	7.8	9
11	12	12.7		35.5	50	42.5	M4x8	M4	20.5	13.5	3	8.5	11
14				35.5	50	42.5	M4x8	M4	24	17	3	10.2	11.5

	M_{n2}	M_{a2}	M_{p2}	n_1	$n_{1 \max}$	φ_s	φ_R	C_t	$R_{1 \max}$	$R_{2 \max}$	$A_{2 \max}$	η	J_G [kgcm ²]	
														
													6 ... 9.52	10 ... 14
i	[Nm]	[Nm]	[Nm]	[min ⁻¹]	[min ⁻¹]	[arcmin]		$\frac{Nm}{arcmin}$	[N]	[N]	[N]	%		
MP 053 1_3	12	22	40	3300	4000	15'	10'	1.0	200	500	600	97	0.06	0.08
MP 053 1_4	15	28	45	3500	5000	15'	10'	1.0	200	500	600	97	0.05	0.06
MP 053 1_5	15	28	45	3500	5000	15'	10'	1.0	200	500	600	97	0.04	0.06
MP 053 1_6	15	28	45	3500	5000	15'	10'	1.0	200	500	600	97	0.03	0.05
MP 053 1_7	15	28	45	4000	6000	15'	10'	1.0	200	500	600	97	0.03	0.05
MP 053 1_9	12	22	40	4000	6000	15'	10'	1.0	200	500	600	97	0.03	0.05
MP 053 2_12	20	30	60	3300	4000	15'	10'	0.9	200	500	600	94	0.06	0.08
MP 053 2_15	20	30	60	3300	4000	15'	10'	0.9	200	500	600	94	0.06	0.08
MP 053 2_16	20	30	60	3500	5000	15'	10'	0.9	200	500	600	94	0.05	0.06
MP 053 2_20	20	30	60	3500	5000	15'	10'	0.9	200	500	600	94	0.04	0.06
MP 053 2_25	20	30	60	3500	5000	15'	10'	0.9	200	500	600	94	0.04	0.06
MP 053 2_28	20	30	60	4000	6000	15'	10'	0.9	200	500	600	94	0.03	0.05
MP 053 2_35	20	30	60	4000	6000	15'	10'	0.9	200	500	600	94	0.03	0.05
MP 053 2_36	15	28	45	4000	6000	15'	10'	0.9	200	500	600	94	0.03	0.05
MP 053 2_45	20	30	60	4000	6000	15'	10'	0.9	200	500	600	94	0.03	0.05
MP 053 2_81	12	22	40	4000	6000	15'	10'	0.9	200	500	600	94	0.03	0.05
MP 053 3_48	20	30	60	4000	5000	17'	12'	0.7	200	500	600	91	0.05	0.07
MP 053 3_60	20	30	60	3500	5000	17'	12'	0.7	200	500	600	91	0.05	0.07
MP 053 3_64	20	30	60	3500	5000	17'	12'	0.7	200	500	600	91	0.05	0.06
MP 053 3_75	20	30	60	3500	5000	17'	12'	0.7	200	500	600	91	0.04	0.06
MP 053 3_80	20	30	60	3500	5000	17'	12'	0.7	200	500	600	91	0.05	0.06
MP 053 3_84	20	30	60	4000	6000	17'	12'	0.7	200	500	600	91	0.03	0.05
MP 053 3_100	20	30	60	3500	5000	17'	12'	0.7	200	500	600	91	0.04	0.06
MP 053 3_112	20	30	60	4000	6000	17'	12'	0.7	200	500	600	91	0.03	0.05
MP 053 3_125	20	30	60	3500	5000	17'	12'	0.7	200	500	600	91	0.04	0.06
MP 053 3_140	20	30	60	4000	6000	17'	12'	0.7	200	500	600	91	0.03	0.05
MP 053 3_144	20	30	60	4000	6000	17'	12'	0.7	200	500	600	91	0.03	0.05
MP 053 3_175	20	30	60	4000	6000	17'	12'	0.7	200	500	600	91	0.03	0.05
MP 053 3_180	20	30	60	4000	6000	17'	12'	0.7	200	500	600	91	0.03	0.05
MP 053 3_216	20	30	60	3500	5000	17'	12'	0.7	200	500	600	91	0.03	0.05
MP 053 3_225	20	30	60	4000	6000	17'	12'	0.7	200	500	600	91	0.03	0.05
MP 053 3_245	20	30	60	4000	6000	17'	12'	0.7	200	500	600	91	0.03	0.05
MP 053 3_252	20	30	60	4000	6000	17'	12'	0.7	200	500	600	91	0.05	0.06
MP 053 3_324	20	30	60	4000	6000	17'	12'	0.7	200	500	600	91	0.03	0.05
MP 053 3_405	20	30	60	4000	6000	17'	12'	0.7	200	500	600	91	0.03	0.05
MP 053 3_567	20	30	60	4000	6000	17'	12'	0.7	200	500	600	91	0.03	0.05
MP 053 3_729	12	22	40	4000	6000	17'	12'	0.7	200	500	600	91	0.03	0.05

MP



MP G 053

25AH ... 80A

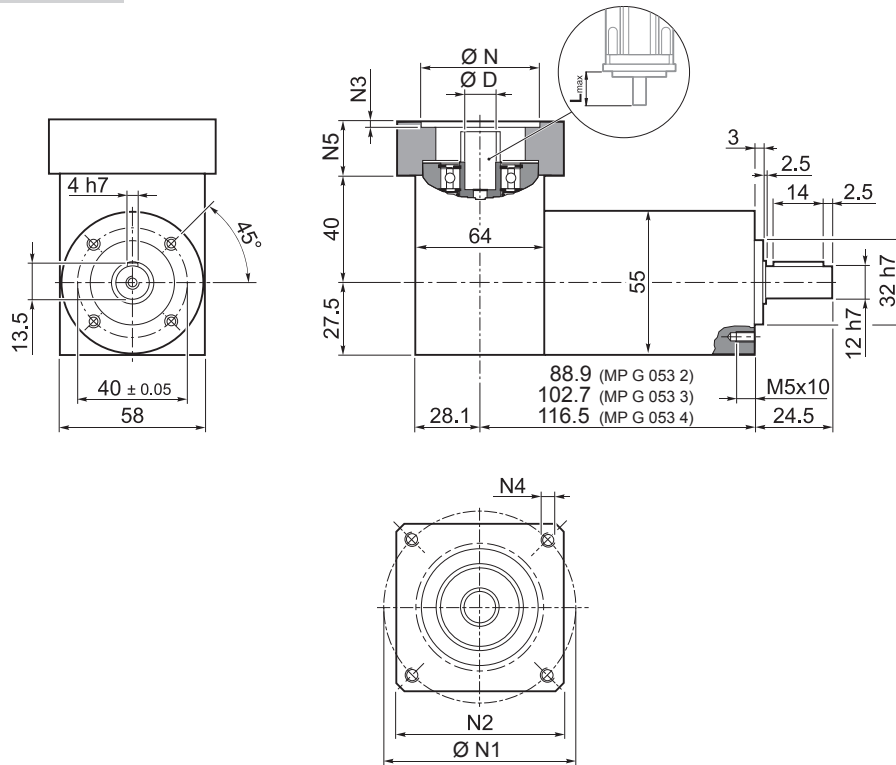

Model	Weight (kg)
MP G 053 2	1.3
MP G 053 3	1.5
MP G 053 4	1.8

MP

Model	D										N	N1		N2	N3	N4	N5	Lmax
	6	6.35	7	8	9	9.52	-	-	-	-		min	max					
25AH	6	6.35	7	8	9	9.52	-	-	-	-	25	36	48					
26AH	6	6.35	7	8	9	9.52	-	-	-	-	26	36	48					
28AH	6	6.35	7	8	9	9.52	-	-	-	-	28	36	48					
30AH	6	6.35	7	8	9	9.52	-	-	-	-	30	36	48					
32AH	6	6.35	7	8	9	9.52	-	-	-	-	32	38	48	55	3.5	4.5	25	25
34AH	6	6.35	7	8	9	9.52	-	-	-	-	34	40	48					
36AH	6	6.35	7	8	9	9.52	-	-	-	-	36	42	48					
38AH	6	6.35	7	8	9	9.52	-	-	-	-	38	44	48					
40AH	6	6.35	7	8	9	9.52	-	-	-	-	40	46	48					
38B	6	6.35	7	8	9	9.52	10	11	12	12.7	38.1	66.6	60	3	M4x10	18	25	
40B	6	6.35	7	8	9	9.52	10	11	12	12.7	40	63	60	3	M4x10	18	25	
50A	6	6.35	7	8	9	9.52	10	11	12	12.7	50	60	60	3	M4x10	18	25	
50B	6	6.35	7	8	9	9.52	10	11	12	12.7	50	65	60	3	M5x12	23	30	
50BH	6	6.35	7	8	9	9.52	10	11	12	12.7	50	65	60	4	5.5	23	30	
50C	6	6.35	7	8	9	9.52	10	11	12	12.7	50	70	60	3	M4x10	23	30	
50MH	6	6.35	7	8	9	9.52	10	11	12	12.7	50	65	55	2	5.5	16	23	
60A	6	6.35	7	8	9	9.52	10	11	12	12.7	60	75	65	3	M5x12	18	25	
60A1	6	6.35	7	8	9	9.52	10	11	12	12.7	60	75	65	3	M5x12	23	30	
60B	6	6.35	7	8	9	9.52	10	11	12	12.7	60	85	75	3	M5x12	23	30	
60C	6	6.35	7	8	9	9.52	10	11	12	12.7	60	90	75	3	M5x12	23	30	
70A	6	6.35	7	8	9	9.52	10	11	12	12.7	70	85	75	3	M6x15	23	30	
70B	6	6.35	7	8	9	9.52	10	11	12	12.7	70	90	75	3	M5x12	23	30	
73A	6	6.35	7	8	9	9.52	10	11	12	12.7	73	98.4	85	3	M5x12	25	32	
80A	6	6.35	7	8	9	9.52	10	11	12	12.7	80	100	85	3	M6x15	23	30	

Für weitere Motoradapter und Antriebswellenbohrungen bitte nachfragen.

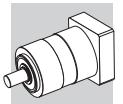

MP G 053

FM

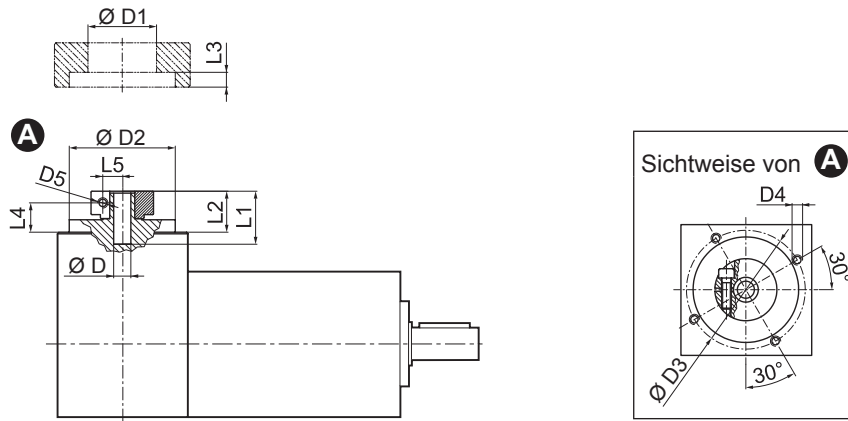

D			D1	D2	D3	D4	D5	L1	L2	L3	L4	L5
6	6.35	7	32.5	50	42.5	M4x8	M4	20.2	13.2	3	8.7	8
8	9	9.52	32.5	50	42.5	M4x8	M4	20.2	13.2	3	7.8	9
11	12	12.7	35.5	50	42.5	M4x8	M4	20.5	13.5	3	8.5	11
14			35.5	50	42.5	M4x8	M4	24	17	3	10.2	11.5

i	M _{n 2}	M _{a 2}	M _{p 2}	n ₁	n _{1 max}	φ _S	φ _R	C _t	R _{2 max}	A _{2 max}	η	J _G [kgcm ²]	
	[Nm]	[Nm]	[Nm]	[min ⁻¹]	[min ⁻¹]	[arcmin]		[$\frac{Nm}{arcmin}$]	[N]	[N]	%	6 ... 9.52	10 ... 14
MP G 053 2_3	12	22	40	3300	4000	15'	10'	1.0	500	600	94	0.18	0.20
MP G 053 2_4	15	28	45	3500	5000	15'	10'	1.0	500	600	94	0.18	0.19
MP G 053 2_5	15	28	45	3500	5000	15'	10'	1.0	500	600	94	0.17	0.19
MP G 053 2_6	15	28	45	3500	5000	15'	10'	1.0	500	600	94	0.17	0.18
MP G 053 2_7	15	28	45	4000	6000	15'	10'	1.0	500	600	94	0.17	0.19
MP G 053 2_9	12	22	40	4000	6000	15'	10'	1.0	500	600	94	0.17	0.18
MP G 053 3_12	20	30	60	3300	4000	15'	10'	0.9	500	600	91	0.18	0.20
MP G 053 3_15	20	30	60	3300	4000	15'	10'	0.9	500	600	91	0.18	0.20
MP G 053 3_16	20	30	60	3500	5000	15'	10'	0.9	500	600	91	0.17	0.19
MP G 053 3_20	20	30	60	3500	5000	15'	10'	0.9	500	600	91	0.17	0.19
MP G 053 3_25	20	30	60	3500	5000	15'	10'	0.9	500	600	91	0.17	0.19
MP G 053 3_28	20	30	60	4000	6000	15'	10'	0.9	500	600	91	0.17	0.19
MP G 053 3_35	20	30	60	4000	6000	15'	10'	0.9	500	600	91	0.17	0.19
MP G 053 3_36	15	28	45	4000	6000	15'	10'	0.9	500	600	91	0.17	0.18
MP G 053 3_45	20	30	60	4000	6000	15'	10'	0.9	500	600	91	0.17	0.19
MP G 053 3_81	12	22	40	4000	6000	15'	10'	0.9	500	600	91	0.17	0.18
MP G 053 4_48	20	30	60	4000	5000	17'	12'	0.7	500	600	89	0.18	0.19
MP G 053 4_60	20	30	60	3500	5000	17'	12'	0.7	500	600	89	0.18	0.19
MP G 053 4_64	20	30	60	3500	5000	17'	12'	0.7	500	600	89	0.17	0.19
MP G 053 4_75	20	30	60	3500	5000	17'	12'	0.7	500	600	89	0.17	0.19
MP G 053 4_80	20	30	60	3500	5000	17'	12'	0.7	500	600	89	0.17	0.19
MP G 053 4_84	20	30	60	4000	6000	17'	12'	0.7	500	600	89	0.17	0.19
MP G 053 4_100	20	30	60	3500	5000	17'	12'	0.7	500	600	89	0.17	0.19
MP G 053 4_112	20	30	60	4000	6000	17'	12'	0.7	500	600	89	0.17	0.19
MP G 053 4_125	20	30	60	3500	5000	17'	12'	0.7	500	600	89	0.17	0.19
MP G 053 4_140	20	30	60	4000	6000	17'	12'	0.7	500	600	89	0.17	0.19
MP G 053 4_144	20	30	60	4000	6000	17'	12'	0.7	500	600	89	0.17	0.18
MP G 053 4_175	20	30	60	4000	6000	17'	12'	0.7	500	600	89	0.17	0.19
MP G 053 4_180	20	30	60	4000	6000	17'	12'	0.7	500	600	89	0.17	0.18
MP G 053 4_216	20	30	60	3500	5000	17'	12'	0.7	500	600	89	0.17	0.18
MP G 053 4_225	20	30	60	4000	6000	17'	12'	0.7	500	600	89	0.17	0.18
MP G 053 4_245	20	30	60	4000	6000	17'	12'	0.7	500	600	89	0.17	0.19
MP G 053 4_252	20	30	60	4000	6000	17'	12'	0.7	500	600	89	0.18	0.20
MP G 053 4_324	20	30	60	4000	6000	17'	12'	0.7	500	600	89	0.17	0.18
MP G 053 4_405	20	30	60	4000	6000	17'	12'	0.7	500	600	89	0.17	0.18
MP G 053 4_567	20	30	60	4000	6000	17'	12'	0.7	500	600	89	0.17	0.18
MP G 053 4_729	12	22	40	4000	6000	17'	12'	0.7	500	600	89	0.17	0.18

MP



MP 060

IS

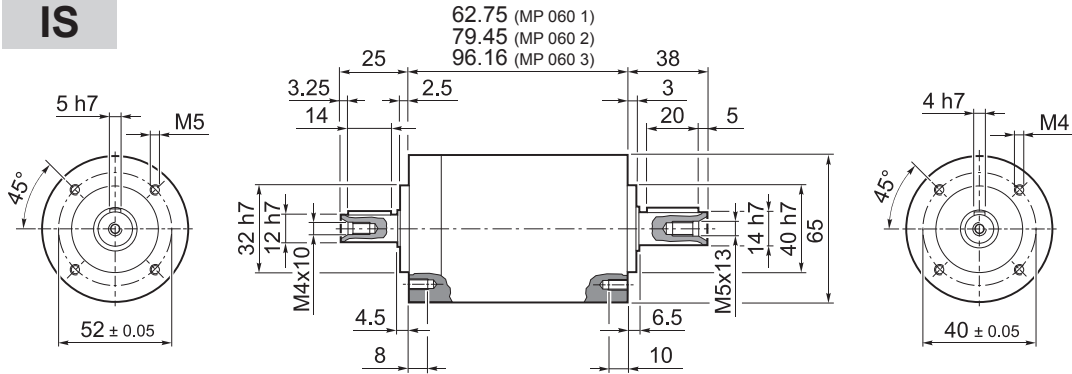

MP 060 1	1.2
MP 060 2	1.7
MP 060 3	2.0

25AH ... 80A

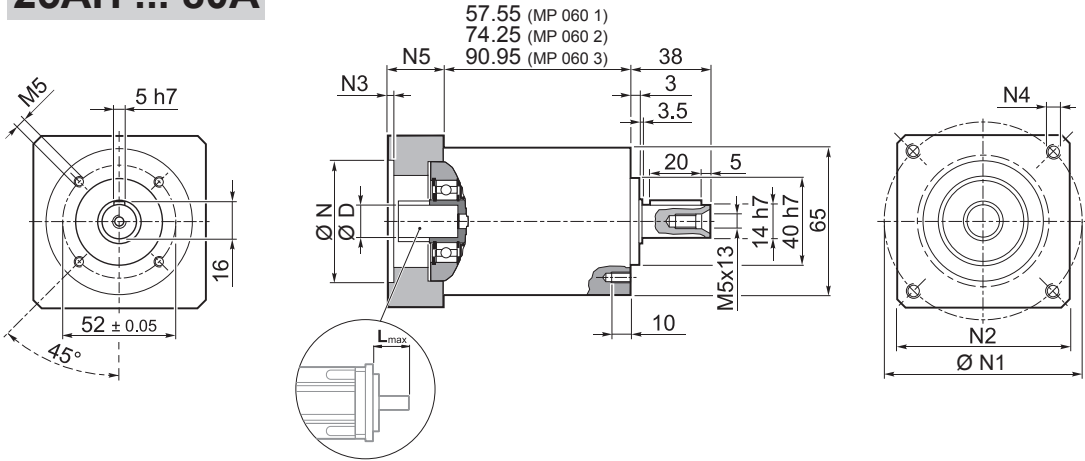

MP 060 1	1.2
MP 060 2	1.7
MP 060 3	2.0

MP

												N	N1		N2	N3	N4	N5	L _{max}
	6	6.35	7	8	8	9	9.52	-	-	-	-		min	max					
25AH	6	6.35	7	8	8	9	9.52	-	-	-	-	25	39	56	65	3.5	4.5	25	25
26AH	6	6.35	7	8	8	9	9.52	-	-	-	-	26	39	56					
28AH	6	6.35	7	8	8	9	9.52	-	-	-	-	28	39	56					
30AH	6	6.35	7	8	8	9	9.52	-	-	-	-	30	39	56					
32AH	6	6.35	7	8	8	9	9.52	-	-	-	-	32	39	56					
34AH	6	6.35	7	8	8	9	9.52	-	-	-	-	34	40	56					
36AH	6	6.35	7	8	8	9	9.52	-	-	-	-	36	42	56					
39AH	6	6.35	7	8	8	9	9.52	-	-	-	-	39	45	56					
40AH	6	6.35	7	8	8	9	9.52	-	-	-	-	40	46	56					
38B	6	6.35	7	8	8	9	9.52	10	11	12	12.7	38.1	66.6	60	3	M4x10	18	25	
40B	6	6.35	7	8	8	9	9.52	10	11	12	12.7	40	63	60	3	M4x10	18	25	
50A	6	6.35	7	8	8	9	9.52	10	11	12	12.7	50	60	60	3	M4x10	18	25	
50B	6	6.35	7	8	8	9	9.52	10	11	12	12.7	50	65	60	3	M5x12	23	30	
50BH	6	6.35	7	8	8	9	9.52	10	11	12	12.7	50	65	65	3	5.5	25	32	
50C	6	6.35	7	8	8	9	9.52	10	11	12	12.7	50	70	60	3	M4x10	23	30	
55MH	6	6.35	7	8	8	9	9.52	10	11	12	12.7	55	80	65	2	5.5	16	23	
60A	6	6.35	7	8	8	9	9.52	10	11	12	12.7	60	75	65	3	M5x12	18	25	
60AH	6	6.35	7	8	8	9	9.52	10	11	12	12.7	60	75	65	3	5.5	18	25	
60A1	6	6.35	7	8	8	9	9.52	10	11	12	12.7	60	75	65	3	M5x12	23	30	
60AH1	6	6.35	7	8	8	9	9.52	10	11	12	12.7	60	75	65	3	5.5	23	30	
60B	6	6.35	7	8	8	9	9.52	10	11	12	12.7	60	85	75	3	M5x12	23	30	
60C	6	6.35	7	8	8	9	9.52	10	11	12	12.7	60	90	75	3	M5x12	23	30	
70A	6	6.35	7	8	8	9	9.52	10	11	12	12.7	70	85	75	3	M6x15	23	30	
70B	6	6.35	7	8	8	9	9.52	10	11	12	12.7	70	90	75	3	M5x12	23	30	
73A	6	6.35	7	8	8	9	9.52	10	11	12	12.7	73	98.4	85	3	M5x12	25	32	
80A	6	6.35	7	8	8	9	9.52	10	11	12	12.7	80	100	85	3	M6x15	23	30	

Für weitere Motoradapter und Antriebswellenbohrungen bitte nachfragen.

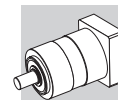

MP 060

FM

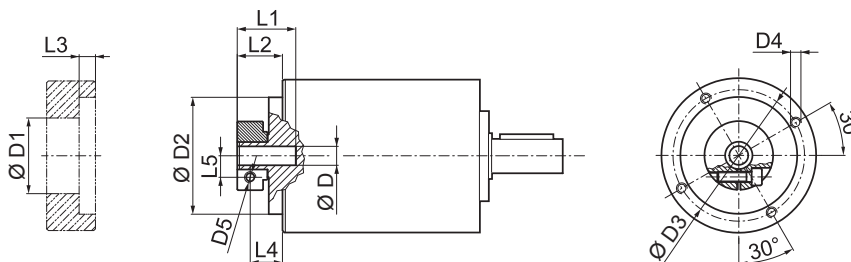

				D1	D2	D3	D4	D5	L1	L2	L3	L4	L5
6	6.35	7		32.5	50	42.5	M4x8	M4	20.2	13.2	3	8.7	8
8	9	9.52	10	32.5	50	42.5	M4x8	M4	20.2	13.2	3	7.8	9
11	12	12.7		35.5	50	42.5	M4x8	M4	20.5	13.5	3	8.5	11
14				35.5	50	42.5	M4x8	M4	24	17	3	10.2	11.5

 i	M _{n2}	M _{a2}	M _{p2}	n ₁	n _{1 max}	φ _s	φ _R	C _t	R _{1 max}	R _{2 max}	A _{2 max}	η	J _G [kgcm ²]	
	[Nm]	[Nm]	[Nm]	[min ⁻¹]	[min ⁻¹]	[arcmin]		$\frac{Nm}{arcmin}$	[N]	[N]	[N]	%		
														6 ... 9.52
MP 060 1_3	18	35	70	3300	4000	15'	10'	3.0	200	600	700	97	0.10	0.11
MP 060 1_4	25	40	90	3500	5000	15'	10'	3.0	200	600	700	97	0.06	0.08
MP 060 1_5	25	40	90	3500	5000	15'	10'	3.0	200	600	700	97	0.05	0.07
MP 060 1_6	25	40	90	3500	5000	15'	10'	3.0	200	600	700	97	0.04	0.06
MP 060 1_7	25	40	90	4000	6000	15'	10'	3.0	200	600	700	97	0.04	0.06
MP 060 1_10	18	35	70	4000	6000	15'	10'	3.0	200	600	700	97	0.03	0.05
MP 060 2_9	18	35	70	3300	4000	15'	10'	2.5	200	600	700	94	0.10	0.12
MP 060 2_12	30	45	100	3300	4000	15'	10'	2.5	200	600	700	94	0.10	0.11
MP 060 2_15	30	45	100	3300	4000	15'	10'	2.5	200	600	700	94	0.09	0.11
MP 060 2_16	30	45	100	3500	5000	15'	10'	2.5	200	600	700	94	0.06	0.08
MP 060 2_20	30	45	100	3500	5000	15'	10'	2.5	200	600	700	94	0.05	0.07
MP 060 2_25	30	45	100	3500	5000	15'	10'	2.5	200	600	700	94	0.05	0.06
MP 060 2_28	30	45	100	4000	6000	15'	10'	2.5	200	600	700	94	0.04	0.06
MP 060 2_30	18	35	70	4000	6000	15'	10'	2.5	200	600	700	94	0.03	0.05
MP 060 2_35	30	45	100	4000	6000	15'	10'	2.5	200	600	700	94	0.04	0.06
MP 060 2_36	25	40	90	3500	5000	15'	10'	2.5	200	600	700	94	0.04	0.06
MP 060 2_40	30	45	100	4000	6000	15'	10'	2.5	200	600	700	94	0.03	0.05
MP 060 2_50	30	45	100	4000	6000	15'	10'	2.5	200	600	700	94	0.03	0.05
MP 060 2_70	30	45	100	4000	6000	15'	10'	2.5	200	600	700	94	0.03	0.05
MP 060 2_100	18	35	70	4000	6000	15'	10'	2.5	200	600	700	94	0.03	0.05
MP 060 3_48	30	45	100	3500	5000	17'	12'	1.8	200	600	700	91	0.06	0.08
MP 060 3_64	30	45	100	3500	5000	17'	12'	1.8	200	600	700	91	0.06	0.08
MP 060 3_75	30	45	100	3500	5000	17'	12'	1.8	200	600	700	91	0.05	0.07
MP 060 3_80	30	45	100	3500	5000	17'	12'	1.8	200	600	700	91	0.06	0.08
MP 060 3_84	30	45	100	4000	6000	17'	12'	1.8	200	600	700	91	0.04	0.06
MP 060 3_90	18	35	70	4000	6000	17'	12'	1.8	200	600	700	91	0.03	0.05
MP 060 3_120	30	45	100	4000	6000	17'	12'	1.8	200	600	700	91	0.03	0.05
MP 060 3_125	30	45	100	3500	5000	17'	12'	1.8	200	600	700	91	0.05	0.07
MP 060 3_140	30	45	100	4000	6000	17'	12'	1.8	200	600	700	91	0.04	0.06
MP 060 3_150	30	45	100	4000	6000	17'	12'	1.8	200	600	700	91	0.03	0.05
MP 060 3_160	30	45	100	4000	6000	17'	12'	1.8	200	600	700	91	0.03	0.05
MP 060 3_175	30	45	100	4000	6000	17'	12'	1.8	200	600	700	91	0.04	0.06
MP 060 3_200	30	45	100	4000	6000	17'	12'	1.8	200	600	700	91	0.03	0.05
MP 060 3_210	30	45	100	4000	6000	17'	12'	1.8	200	600	700	91	0.03	0.05
MP 060 3_216	30	45	100	3500	5000	17'	12'	1.8	200	600	700	91	0.04	0.06
MP 060 3_250	30	45	100	4000	6000	17'	12'	1.8	200	600	700	91	0.03	0.05
MP 060 3_280	30	45	100	4000	6000	17'	12'	1.8	200	600	700	91	0.03	0.05
MP 060 3_350	30	45	100	4000	6000	17'	12'	1.8	200	600	700	91	0.03	0.05
MP 060 3_400	30	45	100	4000	6000	17'	12'	1.8	200	600	700	91	0.03	0.05
MP 060 3_500	30	45	100	4000	6000	17'	12'	1.8	200	600	700	91	0.03	0.05
MP 060 3_700	30	45	100	4000	6000	17'	12'	1.8	200	600	700	91	0.03	0.05
MP 060 3_1000	18	35	70	4000	6000	17'	12'	1.8	200	600	700	91	0.03	0.05

MP



MP G 060

25AH ... 80A

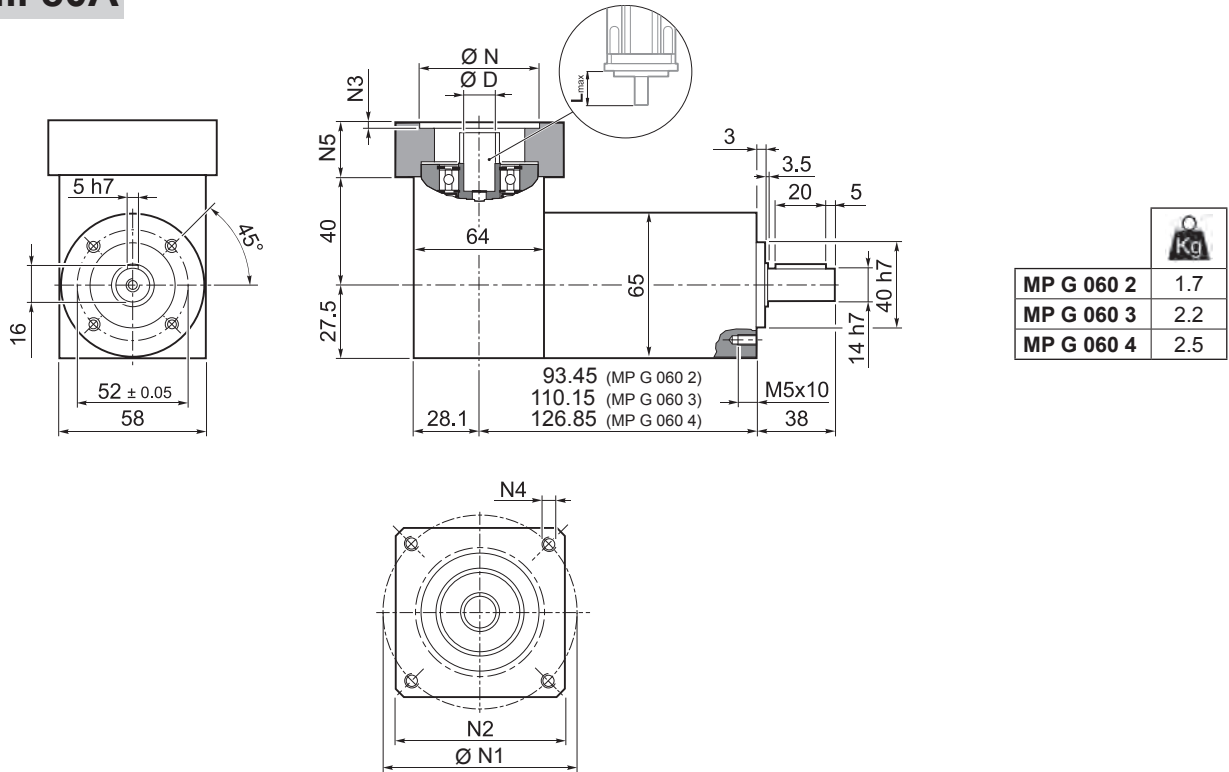

MP

	D											N	N1		N2	N3	N4	N5	L _{max}
	6	6.35	7	8	9	9.52	-	-	-	-	-		min	max					
25AH	6	6.35	7	8	9	9.52	-	-	-	-	-	25	39	56					
26AH	6	6.35	7	8	9	9.52	-	-	-	-	-	26	39	56					
28AH	6	6.35	7	8	9	9.52	-	-	-	-	-	28	39	56					
30AH	6	6.35	7	8	9	9.52	-	-	-	-	-	30	39	56					
32AH	6	6.35	7	8	9	9.52	-	-	-	-	-	32	39	56	65	3.5	4.5	25	25
34AH	6	6.35	7	8	9	9.52	-	-	-	-	-	34	40	56					
36AH	6	6.35	7	8	9	9.52	-	-	-	-	-	36	42	56					
39AH	6	6.35	7	8	9	9.52	-	-	-	-	-	39	45	56					
40AH	6	6.35	7	8	9	9.52	-	-	-	-	-	40	46	56					
38B	6	6.35	7	8	9	9.52	10	11	12	12.7	-	38.1	66.6	60	3	M4x10	18	25	
40B	6	6.35	7	8	9	9.52	10	11	12	12.7	-	40	63	60	3	M4x10	18	25	
50A	6	6.35	7	8	9	9.52	10	11	12	12.7	-	50	60	60	3	M4x10	18	25	
50B	6	6.35	7	8	9	9.52	10	11	12	12.7	14	50	65	60	3	M5x12	23	30	
50BH	6	6.35	7	8	9	9.52	10	11	12	12.7	14	50	65	65	3	5.5	25	32	
50C	6	6.35	7	8	9	9.52	10	11	12	12.7	14	50	70	60	3	M4x10	23	30	
55MH	6	6.35	7	8	9	9.52	10	11	12	12.7	-	55	80	65	2	5.5	16	23	
60A	6	6.35	7	8	9	9.52	10	11	12	12.7	-	60	75	65	3	M5x12	18	25	
60A1	6	6.35	7	8	9	9.52	10	11	12	12.7	14	60	75	65	3	M5x12	23	30	
60B	6	6.35	7	8	9	9.52	10	11	12	12.7	14	60	85	75	3	M5x12	23	30	
60C	6	6.35	7	8	9	9.52	10	11	12	12.7	14	60	90	75	3	M5x12	23	30	
70A	6	6.35	7	8	9	9.52	10	11	12	12.7	14	70	85	75	3	M6x15	23	30	
70B	6	6.35	7	8	9	9.52	10	11	12	12.7	14	70	90	75	3	M5x12	23	30	
73A	6	6.35	7	8	9	9.52	10	11	12	12.7	14	73	98.4	85	3	M5x12	25	32	
80A	6	6.35	7	8	9	9.52	10	11	12	12.7	14	80	100	85	3	M6x15	23	30	

Für weitere Motoradapter und Antriebswellenbohrungen bitte nachfragen.

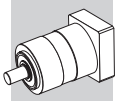

MP G 060

FM

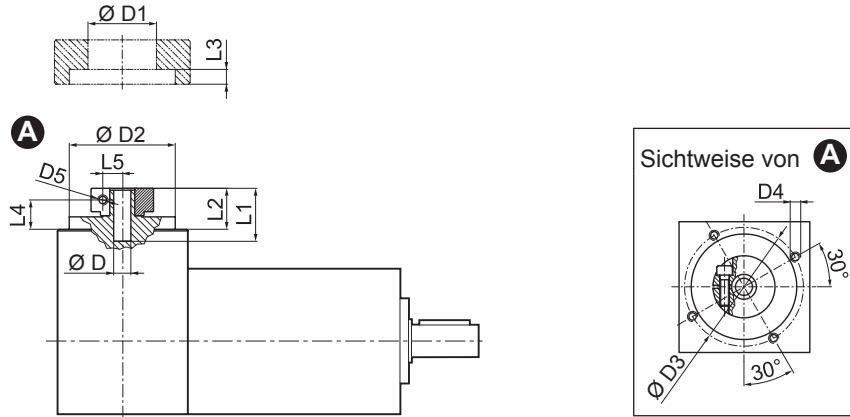

D				D1	D2	D3	D4	D5	L1	L2	L3	L4	L5
6	6.35	7		32.5	50	42.5	M4x8	M4	20.2	13.2	3	8.7	8
8	9	9.52	10	32.5	50	42.5	M4x8	M4	20.2	13.2	3	7.8	9
11	12	12.7		35.5	50	42.5	M4x8	M4	20.5	13.5	3	8.5	11
14				35.5	50	42.5	M4x8	M4	24	17	3	10.2	11.5

i	M _{n 2} [Nm]	M _{a 2} [Nm]	M _{p 2} [Nm]	n ₁ [min ⁻¹]	n _{1 max} [min ⁻¹]	Φ _S [arcmin]	Φ _R [arcmin]	C _t [Nm/arcmin]	R _{2 max} [N]	A _{2 max} [N]	η %	J _G [kgcm ²]	
												D	D
MP G 060 2_3	18	35	70	3300	4000	15'	10'	3.0	600	700	94	6 ... 9.52	10 ... 14
MP G 060 2_4	25	40	90	3500	5000	15'	10'	3.0	600	700	94	0.18	0.20
MP G 060 2_5	25	40	90	3500	5000	15'	10'	3.0	600	700	94	0.17	0.19
MP G 060 2_6	25	40	90	3500	5000	15'	10'	3.0	600	700	94	0.17	0.19
MP G 060 2_7	25	40	90	4000	6000	15'	10'	3.0	600	700	94	0.17	0.19
MP G 060 2_10	18	35	70	4000	6000	15'	10'	3.0	600	700	94	0.17	0.18
MP G 060 3_9	18	35	70	3300	4000	15'	10'	2.5	600	700	91	0.20	0.21
MP G 060 3_12	30	45	100	3300	4000	15'	10'	2.5	600	700	91	0.20	0.21
MP G 060 3_15	30	45	100	3300	4000	15'	10'	2.5	600	700	91	0.19	0.21
MP G 060 3_16	30	45	100	3500	5000	15'	10'	2.5	600	700	91	0.18	0.20
MP G 060 3_20	30	45	100	3500	5000	15'	10'	2.5	600	700	91	0.17	0.19
MP G 060 3_25	30	45	100	3500	5000	15'	10'	2.5	600	700	91	0.17	0.18
MP G 060 3_28	30	45	100	4000	6000	15'	10'	2.5	600	700	91	0.17	0.19
MP G 060 3_30	18	35	70	4000	6000	15'	10'	2.5	600	700	91	0.17	0.18
MP G 060 3_35	30	45	100	4000	6000	15'	10'	2.5	600	700	91	0.18	0.19
MP G 060 3_36	25	40	90	3500	5000	15'	10'	2.5	600	700	91	0.18	0.19
MP G 060 3_40	30	45	100	4000	6000	15'	10'	2.5	600	700	91	0.17	0.18
MP G 060 3_50	30	45	100	4000	6000	15'	10'	2.5	600	700	91	0.17	0.18
MP G 060 3_70	30	45	100	4000	6000	15'	10'	2.5	600	700	91	0.17	0.18
MP G 060 3_100	18	35	70	4000	6000	15'	10'	2.5	600	700	91	0.17	0.18
MP G 060 4_48	30	45	100	3500	5000	17'	12'	1.8	600	700	89	0.18	0.20
MP G 060 4_64	30	45	100	3500	5000	17'	12'	1.8	600	700	89	0.18	0.20
MP G 060 4_75	30	45	100	3500	5000	17'	12'	1.8	600	700	89	0.17	0.19
MP G 060 4_80	30	45	100	3500	5000	17'	12'	1.8	600	700	89	0.18	0.20
MP G 060 4_84	30	45	100	4000	6000	17'	12'	1.8	600	700	89	0.17	0.19
MP G 060 4_90	18	35	70	4000	6000	17'	12'	1.8	600	700	89	0.17	0.18
MP G 060 4_120	30	45	100	4000	6000	17'	12'	1.8	600	700	89	0.15	0.17
MP G 060 4_125	30	45	100	3500	5000	17'	12'	1.8	600	700	89	0.17	0.19
MP G 060 4_140	30	45	100	4000	6000	17'	12'	1.8	600	700	89	0.17	0.19
MP G 060 4_150	30	45	100	4000	6000	17'	12'	1.8	600	700	89	0.17	0.18
MP G 060 4_160	30	45	100	4000	6000	17'	12'	1.8	600	700	89	0.17	0.18
MP G 060 4_175	30	45	100	4000	6000	17'	12'	1.8	600	700	89	0.17	0.19
MP G 060 4_200	30	45	100	4000	6000	17'	12'	1.8	600	700	89	0.17	0.18
MP G 060 4_210	30	45	100	4000	6000	17'	12'	1.8	600	700	89	0.17	0.18
MP G 060 4_216	30	45	100	3500	5000	17'	12'	1.8	600	700	89	0.17	0.19
MP G 060 4_250	30	45	100	4000	6000	17'	12'	1.8	600	700	89	0.17	0.18
MP G 060 4_280	30	45	100	4000	6000	17'	12'	1.8	600	700	89	0.17	0.18
MP G 060 4_350	30	45	100	4000	6000	17'	12'	1.8	600	700	89	0.17	0.18
MP G 060 4_400	30	45	100	4000	6000	17'	12'	1.8	600	700	89	0.17	0.18
MP G 060 4_500	30	45	100	4000	6000	17'	12'	1.8	600	700	89	0.17	0.18
MP G 060 4_700	30	45	100	4000	6000	17'	12'	1.8	600	700	89	0.17	0.18
MP G 060 4_1000	18	35	70	4000	6000	17'	12'	1.8	600	700	89	0.17	0.18

MP



MP 080

IS

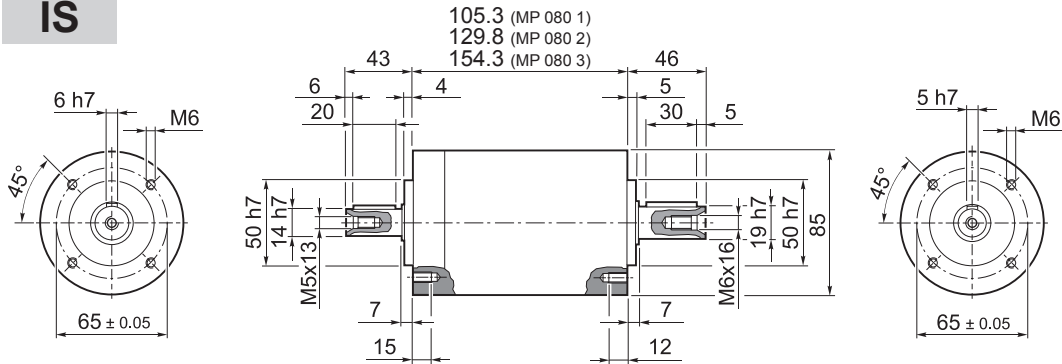

MP 080 1	4.0
MP 080 2	4.6
MP 080 3	5.2

40B1 ... 110B1

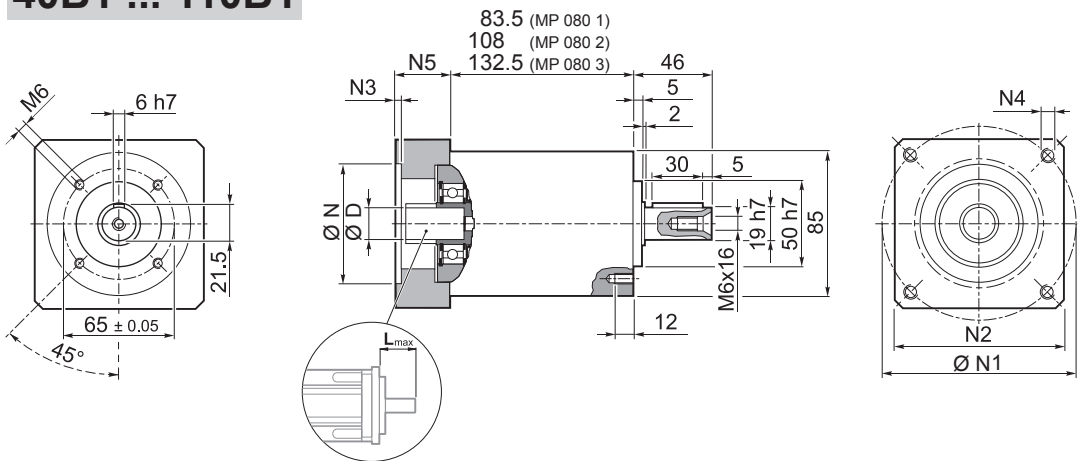

MP 080 1	4.0
MP 080 2	4.6
MP 080 3	5.2

MP

											N	N1	N2	N3	N4	N5	L _{max}		
40B1	8	9	9.52	11	12	12.7	14	-	-	-	-	40	63	80	4	M4x12	34	40	
45A	8	9	9.52	11	12	12.7	-	-	-	-	-	45	63	80	4	M4x12	34	40	
50B1	8	9	9.52	11	12	12.7	14	-	-	-	-	50	65	80	4	M5x16	34	40	
50BH1	8	9	9.52	11	12	12.7	14	-	-	-	-	50	65	80	4	5.5	34	40	
50C1	8	9	9.52	11	12	12.7	14	-	-	-	-	50	70	80	4	M4x10	34	40	
50D	8	9	9.52	11	12	12.7	14	-	-	-	-	50	95	80	4	M6x20	34	40	
55A	8	9	9.52	11	12	12.7	14	15.875	16	17	19	19.05	55.5	125.7	105	4	M6x20	34	40
60A2	8	9	9.52	11	12	12.7	14	-	-	-	-	60	75	80	4	M5x16	34	40	
60AH2	8	9	9.52	11	12	12.7	14	-	-	-	-	60	75	90	4	6.5	34	40	
60B1	8	9	9.52	11	12	12.7	14	15.875	16	-	-	60	85	80	4	M5x16	34	40	
60C1	8	9	9.52	11	12	12.7	14	15.875	16	-	-	60	90	80	4	M5x16	34	40	
70A1	8	9	9.52	11	12	12.7	14	15.875	16	17	19	19.05	70	85	80	4	M6x20	34	40
70AH1	8	9	9.52	11	12	12.7	14	15.875	16	17	19	19.05	70	85	90	4	6.5	34	40
70B1	8	9	9.52	11	12	12.7	14	15.875	16	17	19	19.05	70	90	80	4	M5x16	34	40
73A1	8	9	9.52	11	12	12.7	14	-	-	-	-	73	98.4	85	4	M5x16	34	40	
80A1	8	9	9.52	11	12	12.7	14	15.875	16	17	19	19.05	80	100	90	4	M6x16	34	40
95A	8	9	9.52	11	12	12.7	14	15.875	16	17	19	19.05	95	115	100	4	M8x20	34	40
95B	8	9	9.52	11	12	12.7	14	15.875	16	17	19	19.05	95	130	115	4	M8x20	34	40
110A	8	9	9.52	11	12	12.7	14	15.875	16	17	19	19.05	110	130	115	4	M8x20	34	40
110B	8	9	9.52	11	12	12.7	14	15.875	16	17	19	19.05	110	145	120	6.5	M8x20	44	50
110B1	8	9	9.52	11	12	12.7	14	15.875	16	17	19	19.05	110	145	120	6.5	M8x20	54	60

Für weitere Motoradapter und Antriebswellenbohrungen bitte nachfragen.

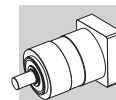

MP 080

FM

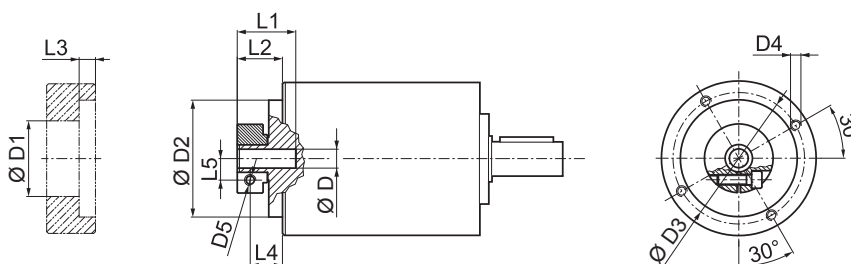

D				D1	D2	D3	D4	D5	L1	L2	L3	L4	L5
8	9	9.52		38	68	76.5	M6x12	M6	32.2	26.3	9.5	19.3	10.5
11	12	12.7		43	68	76.5	M6x12	M6	32.2	26.3	9.5	19.3	12.5
14	15.875	16	17	48	68	76.5	M6x12	M6	32.2	26.3	9.5	19.3	14.5
19	19.05			51	68	76.5	M6x12	M6	32.2	26.3	9.5	19.3	16.5

 i	M _{n 2}	M _{a 2}	M _{p 2}	n ₁	n _{1 max}	φ _s	φ _R	C _t	R _{1 max}	R _{2 max}	A _{2 max}	R _{2 max}	A _{2 max}	η	J _G [kgcm ²]	
	[Nm]	[Nm]	[Nm]	[min ⁻¹]	[min ⁻¹]	[arcmin]	[Nm/arcmin]	[N]	[N]	[N]	[N]	[N]	[N]	%	8 ... 12.7	14 ... 19.05
MP 080 1_3	40	80	180	2900	3500	15'	10'	7.0	400	1300	1400	2500	3000	97	0.50	0.59
MP 080 1_4	50	80	200	3100	4500	15'	10'	7.0	400	1300	1400	2500	3000	97	0.34	0.43
MP 080 1_5	50	80	200	3200	4500	15'	10'	7.0	400	1300	1400	2500	3000	97	0.28	0.37
MP 080 1_6	50	80	200	3200	4500	15'	10'	7.0	400	1300	1400	2500	3000	97	0.21	0.30
MP 080 1_7	50	80	200	4000	6000	15'	10'	7.0	400	1300	1400	2500	3000	97	0.23	0.32
MP 080 1_10	40	80	180	4000	6000	15'	10'	7.0	400	1300	1400	2500	3000	97	0.20	0.29
MP 080 2_9	40	80	180	2900	3500	15'	10'	5.9	400	1300	1400	2500	3000	94	0.49	0.58
MP 080 2_12	70	100	250	2900	3500	15'	10'	5.9	400	1300	1400	2500	3000	94	0.47	0.56
MP 080 2_15	70	100	250	2900	3500	15'	10'	5.9	400	1300	1400	2500	3000	94	0.46	0.55
MP 080 2_16	70	100	250	3100	4500	15'	10'	5.9	400	1300	1400	2500	3000	94	0.32	0.41
MP 080 2_20	70	100	250	3200	4500	15'	10'	5.9	400	1300	1400	2500	3000	94	0.27	0.36
MP 080 2_25	70	100	250	3200	4500	15'	10'	5.9	400	1300	1400	2500	3000	94	0.27	0.36
MP 080 2_28	70	100	250	4000	6000	15'	10'	5.9	400	1300	1400	2500	3000	94	0.22	0.31
MP 080 2_30	40	80	180	4000	6000	15'	10'	5.9	400	1300	1400	2500	3000	94	0.20	0.29
MP 080 2_35	70	100	250	4000	6000	15'	10'	5.9	400	1300	1400	2500	3000	94	0.22	0.31
MP 080 2_36	50	80	200	3200	4500	15'	10'	5.9	400	1300	1400	2500	3000	94	0.20	0.29
MP 080 2_40	70	100	250	4000	6000	15'	10'	5.9	400	1300	1400	2500	3000	94	0.20	0.29
MP 080 2_50	70	100	250	4000	6000	15'	10'	5.9	400	1300	1400	2500	3000	94	0.19	0.28
MP 080 2_70	70	100	250	4000	6000	15'	10'	5.9	400	1300	1400	2500	3000	94	0.19	0.28
MP 080 2_100	40	80	180	4000	6000	15'	10'	5.9	400	1300	1400	2500	3000	94	0.19	0.28
MP 080 3_48	70	100	250	3100	4500	17'	12'	5.4	400	1300	1400	2500	3000	91	0.33	0.42
MP 080 3_64	70	100	250	3100	4500	17'	12'	5.4	400	1300	1400	2500	3000	91	0.32	0.41
MP 080 3_75	70	100	250	3200	4500	17'	12'	5.4	400	1300	1400	2500	3000	91	0.27	0.36
MP 080 3_80	70	100	250	3100	4500	17'	12'	5.4	400	1300	1400	2500	3000	91	0.32	0.41
MP 080 3_84	70	100	250	4000	6000	17'	12'	5.4	400	1300	1400	2500	3000	91	0.23	0.32
MP 080 3_90	40	80	180	4000	6000	17'	12'	5.4	400	1300	1400	2500	3000	91	0.20	0.29
MP 080 3_120	70	100	250	4000	6000	17'	12'	5.4	400	1300	1400	2500	3000	91	0.20	0.29
MP 080 3_125	70	100	250	3200	4500	17'	12'	5.4	400	1300	1400	2500	3000	91	0.27	0.36
MP 080 3_140	70	100	250	4000	6000	17'	12'	5.4	400	1300	1400	2500	3000	91	0.22	0.31
MP 080 3_150	70	100	250	4000	6000	17'	12'	5.4	400	1300	1400	2500	3000	91	0.20	0.29
MP 080 3_160	70	100	250	4000	6000	17'	12'	5.4	400	1300	1400	2500	3000	91	0.20	0.29
MP 080 3_175	70	100	250	4000	6000	17'	12'	5.4	400	1300	1400	2500	3000	91	0.22	0.31
MP 080 3_200	70	100	250	4000	6000	17'	12'	5.4	400	1300	1400	2500	3000	91	0.20	0.29
MP 080 3_210	70	100	250	4000	6000	17'	12'	5.4	400	1300	1400	2500	3000	91	0.20	0.29
MP 080 3_216	70	100	250	3200	4500	17'	12'	5.4	400	1300	1400	2500	3000	91	0.20	0.29
MP 080 3_250	70	100	250	4000	6000	17'	12'	5.4	400	1300	1400	2500	3000	91	0.19	0.28
MP 080 3_280	70	100	250	4000	6000	17'	12'	5.4	400	1300	1400	2500	3000	91	0.19	0.28
MP 080 3_350	70	100	250	4000	6000	17'	12'	5.4	400	1300	1400	2500	3000	91	0.19	0.28
MP 080 3_400	70	100	250	4000	6000	17'	12'	5.4	400	1300	1400	2500	3000	91	0.19	0.28
MP 080 3_500	70	100	250	4000	6000	17'	12'	5.4	400	1300	1400	2500	3000	91	0.19	0.28
MP 080 3_700	70	100	250	4000	6000	17'	12'	5.4	400	1300	1400	2500	3000	91	0.19	0.28
MP 080 3_1000	40	80	180	4000	6000	17'	12'	5.4	400	1300	1400	2500	3000	91	0.19	0.28

MP



MP G 080

40B1 ... 110B1

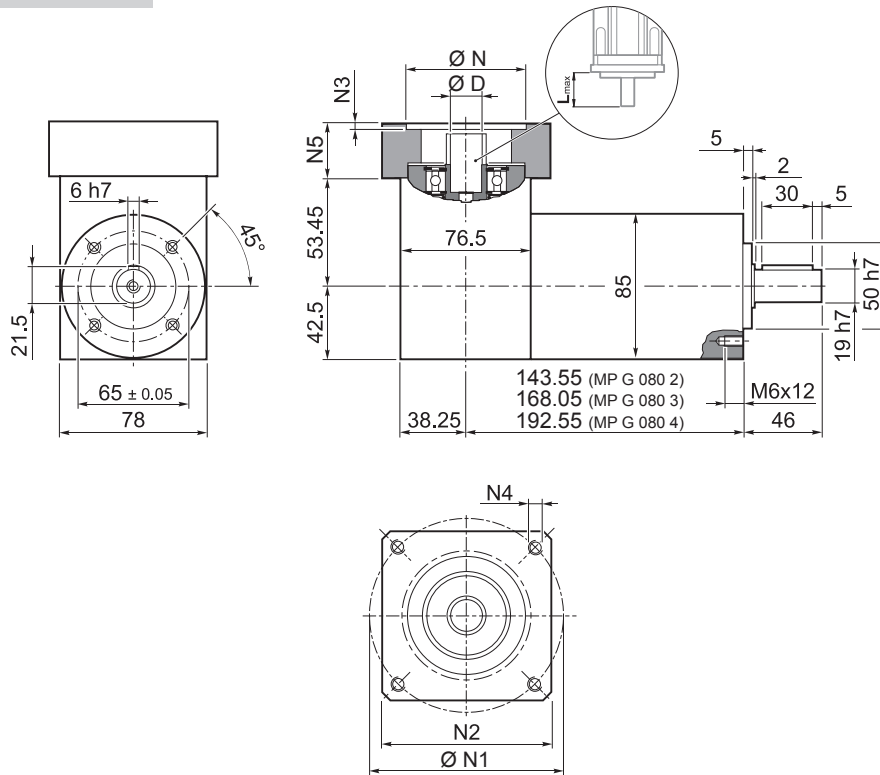

	
MP G 080 2	5.2
MP G 080 3	5.8
MP G 080 4	6.4

MP

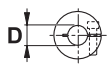
											N	N1	N2	N3	N4	N5	L _{max}	
40B1	8	9	9.52	11	12	12.7	14	-	-	-	-	40	63	80	4	M4x12	34	40
45A	8	9	9.52	11	12	12.7	-	-	-	-	-	45	63	80	4	M4x12	34	40
50B1	8	9	9.52	11	12	12.7	14	-	-	-	-	50	65	80	4	M5x16	34	40
50BH1	8	9	9.52	11	12	12.7	14	-	-	-	-	50	65	80	4	5.5	34	40
50C1	8	9	9.52	11	12	12.7	14	-	-	-	-	50	70	80	4	M4x10	34	40
50D	8	9	9.52	11	12	12.7	14	-	-	-	-	50	95	80	4	M6x20	34	40
55A	8	9	9.52	11	12	12.7	14	15.875	16	17	19	55.5	125.7	105	4	M6x20	34	40
60A2	8	9	9.52	11	12	12.7	14	-	-	-	-	60	75	80	4	M5x16	34	40
60AH2	8	9	9.52	11	12	12.7	14	-	-	-	-	60	75	90	4	6.5	34	40
60B1	8	9	9.52	11	12	12.7	14	15.875	16	-	-	60	85	80	4	M5x16	34	40
60C1	8	9	9.52	11	12	12.7	14	15.875	16	-	-	60	90	80	4	M5x16	34	40
70A1	8	9	9.52	11	12	12.7	14	15.875	16	17	19	70	85	80	4	M6x20	34	40
70AH1	8	9	9.52	11	12	12.7	14	15.875	16	17	19	70	85	90	4	6.5	34	40
70B1	8	9	9.52	11	12	12.7	14	15.875	16	17	19	70	90	80	4	M5x16	34	40
73A1	8	9	9.52	11	12	12.7	14	-	-	-	-	73	98.4	85	4	M5x16	34	40
80A1	8	9	9.52	11	12	12.7	14	15.875	16	17	19	80	100	90	4	M6x16	34	40
95A	8	9	9.52	11	12	12.7	14	15.875	16	17	19	95	115	100	4	M8x20	34	40
95B	8	9	9.52	11	12	12.7	14	15.875	16	17	19	95	130	115	4	M8x20	34	40
110A	8	9	9.52	11	12	12.7	14	15.875	16	17	19	110	130	115	4	M8x20	34	40
110B	8	9	9.52	11	12	12.7	14	15.875	16	17	19	110	145	120	6.5	M8x20	44	50
110B1	8	9	9.52	11	12	12.7	14	15.875	16	17	19	110	145	120	6.5	M8x20	54	60

Für weitere Motoradapter und Antriebswellenbohrungen bitte nachfragen.

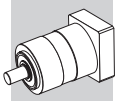

MP G 080

FM

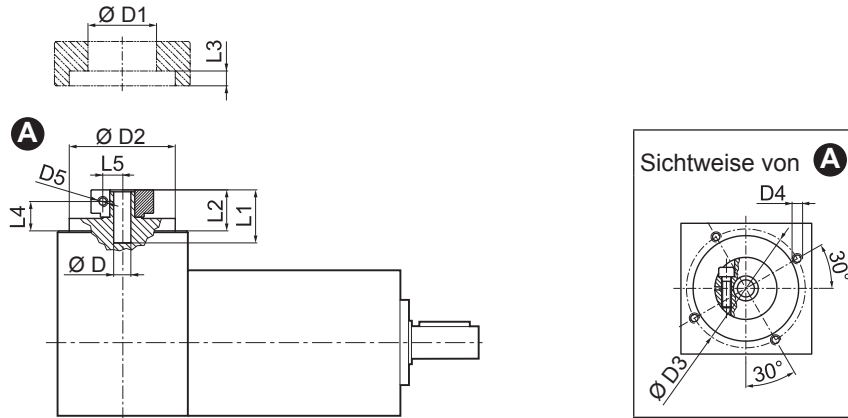

D			D1	D2	D3	D4	D5	L1	L2	L3	L4	L5
8	9	9.52	38	68	76.5	M6x12	M6	32.2	26.3	9.5	19.3	10.5
11	12	12.7	43	68	76.5	M6x12	M6	32.2	26.3	9.5	19.3	12.5
14	15.875	16	48	68	76.5	M6x12	M6	32.2	26.3	9.5	19.3	14.5
19	19.05		51	68	76.5	M6x12	M6	32.2	26.3	9.5	19.3	16.5

i	M _{n 2} [Nm]	M _{a 2} [Nm]	M _{p 2} [Nm]	n ₁ [min ⁻¹]	n _{1 max} [min ⁻¹]	φ _S [arcmin]	φ _R [arcmin]	C _t [Nm/arcmin]	SB		HB		η %	J _G [kgcm ²]	
									R _{2 max} [N]	A _{2 max} [N]	R _{2 max} [N]	A _{2 max} [N]		8 ... 12.7	14 ... 19.05
MP G 080 2_3	40	80	180	2900	3500	15'	10'	7.0	1300	1400	2500	3000	94	0.67	0.79
MP G 080 2_4	50	80	200	3100	4500	15'	10'	7.0	1300	1400	2500	3000	94	0.62	0.75
MP G 080 2_5	50	80	200	3200	4500	15'	10'	7.0	1300	1400	2500	3000	94	0.61	0.74
MP G 080 2_6	50	80	200	3200	4500	15'	10'	7.0	1300	1400	2500	3000	94	0.58	0.71
MP G 080 2_7	50	80	200	4000	6000	15'	10'	7.0	1300	1400	2500	3000	94	0.60	0.73
MP G 080 2_10	40	80	180	4000	6000	15'	10'	7.0	1300	1400	2500	3000	94	0.60	0.72
MP G 080 3_9	40	80	180	2900	3500	15'	10'	5.9	1300	1400	2500	3000	91	0.66	0.78
MP G 080 3_12	70	100	250	2900	3500	15'	10'	5.9	1300	1400	2500	3000	91	0.75	0.87
MP G 080 3_15	70	100	250	2900	3500	15'	10'	5.9	1300	1400	2500	3000	91	0.74	0.87
MP G 080 3_16	70	100	250	3100	4500	15'	10'	5.9	1300	1400	2500	3000	91	0.60	0.73
MP G 080 3_20	70	100	250	3200	4500	15'	10'	5.9	1300	1400	2500	3000	91	0.60	0.73
MP G 080 3_25	70	100	250	3200	4500	15'	10'	5.9	1300	1400	2500	3000	91	0.64	0.76
MP G 080 3_28	70	100	250	4000	6000	15'	10'	5.9	1300	1400	2500	3000	91	0.59	0.72
MP G 080 3_30	40	80	180	4000	6000	15'	10'	5.9	1300	1400	2500	3000	91	0.60	0.72
MP G 080 3_35	70	100	250	4000	6000	15'	10'	5.9	1300	1400	2500	3000	91	0.61	0.74
MP G 080 3_36	50	80	200	3200	4500	15'	10'	5.9	1300	1400	2500	3000	91	0.57	0.70
MP G 080 3_40	70	100	250	4000	6000	15'	10'	5.9	1300	1400	2500	3000	91	0.60	0.72
MP G 080 3_50	70	100	250	4000	6000	15'	10'	5.9	1300	1400	2500	3000	91	0.59	0.71
MP G 080 3_70	70	100	250	4000	6000	15'	10'	5.9	1300	1400	2500	3000	91	0.59	0.71
MP G 080 3_100	40	80	180	4000	6000	15'	10'	5.9	1300	1400	2500	3000	91	0.59	0.71
MP G 080 4_48	70	100	250	3100	4500	17'	12'	5.4	1300	1400	2500	3000	89	0.61	0.75
MP G 080 4_64	70	100	250	3100	4500	17'	12'	5.4	1300	1400	2500	3000	89	0.60	0.73
MP G 080 4_75	70	100	250	3200	4500	17'	12'	5.4	1300	1400	2500	3000	89	0.60	0.73
MP G 080 4_80	70	100	250	3100	4500	17'	12'	5.4	1300	1400	2500	3000	89	0.60	0.73
MP G 080 4_84	70	100	250	4000	6000	17'	12'	5.4	1300	1400	2500	3000	89	0.60	0.73
MP G 080 4_90	40	80	180	4000	6000	17'	12'	5.4	1300	1400	2500	3000	89	0.60	0.72
MP G 080 4_120	70	100	250	4000	6000	17'	12'	5.4	1300	1400	2500	3000	89	0.60	0.72
MP G 080 4_125	70	100	250	3200	4500	17'	12'	5.4	1300	1400	2500	3000	89	0.60	0.73
MP G 080 4_140	70	100	250	4000	6000	17'	12'	5.4	1300	1400	2500	3000	89	0.59	0.72
MP G 080 4_150	70	100	250	4000	6000	17'	12'	5.4	1300	1400	2500	3000	89	0.60	0.72
MP G 080 4_160	70	100	250	4000	6000	17'	12'	5.4	1300	1400	2500	3000	89	0.60	0.72
MP G 080 4_175	70	100	250	4000	6000	17'	12'	5.4	1300	1400	2500	3000	89	0.59	0.72
MP G 080 4_200	70	100	250	4000	6000	17'	12'	5.4	1300	1400	2500	3000	89	0.60	0.72
MP G 080 4_210	70	100	250	4000	6000	17'	12'	5.4	1300	1400	2500	3000	89	0.60	0.72
MP G 080 4_216	70	100	250	3200	4500	17'	12'	5.4	1300	1400	2500	3000	89	0.57	0.70
MP G 080 4_250	70	100	250	4000	6000	17'	12'	5.4	1300	1400	2500	3000	89	0.59	0.71
MP G 080 4_280	70	100	250	4000	6000	17'	12'	5.4	1300	1400	2500	3000	89	0.59	0.71
MP G 080 4_350	70	100	250	4000	6000	17'	12'	5.4	1300	1400	2500	3000	89	0.59	0.71
MP G 080 4_400	70	100	250	4000	6000	17'	12'	5.4	1300	1400	2500	3000	89	0.59	0.71
MP G 080 4_500	70	100	250	4000	6000	17'	12'	5.4	1300	1400	2500	3000	89	0.59	0.71
MP G 080 4_700	70	100	250	4000	6000	17'	12'	5.4	1300	1400	2500	3000	89	0.59	0.71
MP G 080 4_1000	40	80	180	4000	6000	17'	12'	5.4	1300	1400	2500	3000	89	0.59	0.71

MP



MP MB 080

40B1 ... 110B1

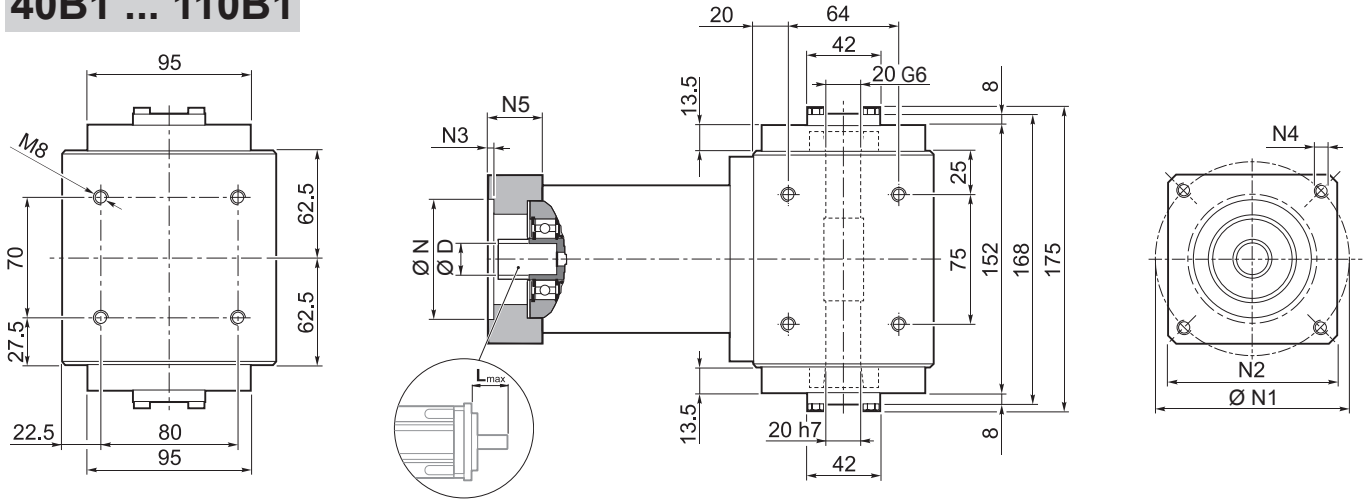

149.5 (MP MB 080 2)
174 (MP MB 080 3)
198.5 (MP MB 080 4)

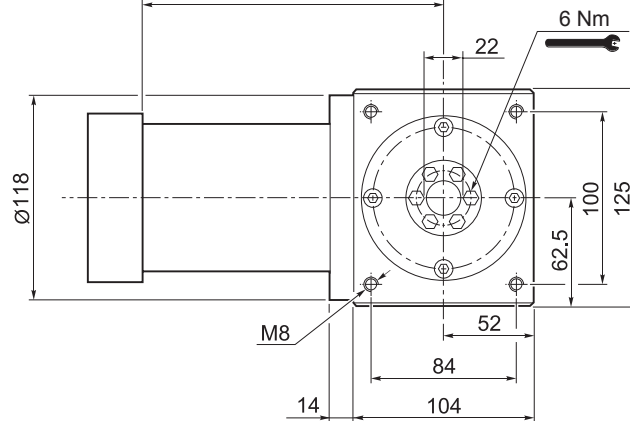

MP MB 080 2	14.0
MP MB 080 3	15.0
MP MB 080 4	16.0

MP

												N	N1	N2	N3	N4	N5	L _{max}	
40B1	8	9	9.52	11	12	12.7	14	-	-	-	-	40	63	80	4	M4x12	34	40	
45A	8	9	9.52	11	12	12.7	-	-	-	-	-	45	63	80	4	M4x12	34	40	
50B1	8	9	9.52	11	12	12.7	14	-	-	-	-	50	65	80	4	M5x16	34	40	
50BH1	8	9	9.52	11	12	12.7	14	-	-	-	-	50	65	80	4	5.5	34	40	
50C1	8	9	9.52	11	12	12.7	14	-	-	-	-	50	70	80	4	M4x10	34	40	
50D	8	9	9.52	11	12	12.7	14	-	-	-	-	50	95	80	4	M6x20	34	40	
55A	8	9	9.52	11	12	12.7	14	15.875	16	17	19	19.05	55.5	125.7	105	4	M6x20	34	40
60A2	8	9	9.52	11	12	12.7	14	-	-	-	-	60	75	80	4	M5x16	34	40	
60AH2	8	9	9.52	11	12	12.7	14	-	-	-	-	60	75	90	4	6.5	34	40	
60B1	8	9	9.52	11	12	12.7	14	15.875	16	-	-	60	85	80	4	M5x16	34	40	
60C1	8	9	9.52	11	12	12.7	14	15.875	16	-	-	60	90	80	4	M5x16	34	40	
70A1	8	9	9.52	11	12	12.7	14	15.875	16	17	19	19.05	70	85	80	4	M6x20	34	40
70AH1	8	9	9.52	11	12	12.7	14	15.875	16	17	19	19.05	70	85	90	4	6.5	34	40
70B1	8	9	9.52	11	12	12.7	14	15.875	16	17	19	19.05	70	90	80	4	M5x16	34	40
73A1	8	9	9.52	11	12	12.7	14	-	-	-	-	73	98.4	85	4	M5x16	34	40	
80A1	8	9	9.52	11	12	12.7	14	15.875	16	17	19	19.05	80	100	90	4	M6x16	34	40
95A	8	9	9.52	11	12	12.7	14	15.875	16	17	19	19.05	95	115	100	4	M8x20	34	40
95B	8	9	9.52	11	12	12.7	14	15.875	16	17	19	19.05	95	130	115	4	M8x20	34	40
110A	8	9	9.52	11	12	12.7	14	15.875	16	17	19	19.05	110	130	115	4	M8x20	34	40
110B	8	9	9.52	11	12	12.7	14	15.875	16	17	19	19.05	110	145	120	6.5	M8x20	44	50
110B1	8	9	9.52	11	12	12.7	14	15.875	16	17	19	19.05	110	145	120	6.5	M8x20	54	60

Für weitere Motoradapter und Antriebswellenbohrungen bitte nachfragen.

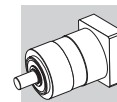

MP MB 080

FM

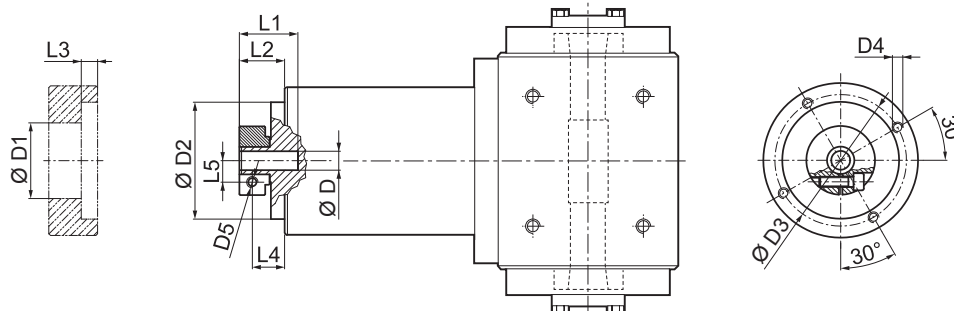

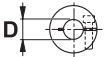
				D1	D2	D3	D4	D5	L1	L2	L3	L4	L5
8	9	9.52		38	68	76.5	M6x12	M6	32.2	26.3	9.5	19.3	10.5
11	12	12.7		43	68	76.5	M6x12	M6	32.2	26.3	9.5	19.3	12.5
14	15.875	16	17	48	68	76.5	M6x12	M6	32.2	26.3	9.5	19.3	14.5
19	19.05			51	68	76.5	M6x12	M6	32.2	26.3	9.5	19.3	16.5

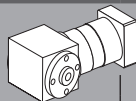
	i	M _{n2}	M _{a2}	M _{p2}	n ₁	n _{1 max}	φ _s	φ _R	C _t	η	J _G [kgcm ²]	
		[Nm]	[Nm]	[Nm]	[min ⁻¹]	[min ⁻¹]	[arcmin]	[Nm/arcmin]	%	8 ... 12.7	14 ... 19.05	
MP MB 080 2_3		40	80	180	2900	3500	15'	10'	7.0	94	0.50	0.59
MP MB 080 2_4		50	80	200	3100	4500	15'	10'	7.0	94	0.34	0.43
MP MB 080 2_5		50	80	200	3200	4500	15'	10'	7.0	94	0.28	0.37
MP MB 080 2_6		50	80	200	3200	4500	15'	10'	7.0	94	0.21	0.30
MP MB 080 2_7		50	80	200	4000	6000	15'	10'	7.0	94	0.23	0.32
MP MB 080 2_10		40	80	180	4000	6000	15'	10'	7.0	94	0.20	0.29
MP MB 080 3_9		40	80	180	2900	3500	15'	10'	5.9	91	0.49	0.58
MP MB 080 3_12		70	100	250	2900	3500	15'	10'	5.9	91	0.47	0.56
MP MB 080 3_15		70	100	250	2900	3500	15'	10'	5.9	91	0.46	0.55
MP MB 080 3_16		70	100	250	3100	4500	15'	10'	5.9	91	0.32	0.41
MP MB 080 3_20		70	100	250	3200	4500	15'	10'	5.9	91	0.27	0.36
MP MB 080 3_25		70	100	250	3200	4500	15'	10'	5.9	91	0.27	0.36
MP MB 080 3_28		70	100	250	4000	6000	15'	10'	5.9	91	0.22	0.31
MP MB 080 3_30		40	80	180	4000	6000	15'	10'	5.9	91	0.20	0.29
MP MB 080 3_35		70	100	250	4000	6000	15'	10'	5.9	91	0.22	0.31
MP MB 080 3_36		50	80	200	3200	4500	15'	10'	5.9	91	0.20	0.29
MP MB 080 3_40		70	100	250	4000	6000	15'	10'	5.9	91	0.20	0.29
MP MB 080 3_50		70	100	250	4000	6000	15'	10'	5.9	91	0.19	0.28
MP MB 080 3_70		70	100	250	4000	6000	15'	10'	5.9	91	0.19	0.28
MP MB 080 3_100		40	80	180	4000	6000	15'	10'	5.9	91	0.19	0.28
MP MB 080 4_48		70	100	250	3100	4500	17'	12'	5.4	89	0.33	0.42
MP MB 080 4_64		70	100	250	3100	4500	17'	12'	5.4	89	0.32	0.41
MP MB 080 4_75		70	100	250	3200	4500	17'	12'	5.4	89	0.27	0.36
MP MB 080 4_80		70	100	250	3100	4500	17'	12'	5.4	89	0.32	0.41
MP MB 080 4_84		70	100	250	4000	6000	17'	12'	5.4	89	0.23	0.32
MP MB 080 4_90		40	80	180	4000	6000	17'	12'	5.4	89	0.20	0.29
MP MB 080 4_120		70	100	250	4000	6000	17'	12'	5.4	89	0.20	0.29
MP MB 080 4_125		70	100	250	3200	4500	17'	12'	5.4	89	0.27	0.36
MP MB 080 4_140		70	100	250	4000	6000	17'	12'	5.4	89	0.22	0.31
MP MB 080 4_150		70	100	250	4000	6000	17'	12'	5.4	89	0.20	0.29
MP MB 080 4_160		70	100	250	4000	6000	17'	12'	5.4	89	0.20	0.29
MP MB 080 4_175		70	100	250	4000	6000	17'	12'	5.4	89	0.22	0.31
MP MB 080 4_200		70	100	250	4000	6000	17'	12'	5.4	89	0.20	0.29
MP MB 080 4_210		70	100	250	4000	6000	17'	12'	5.4	89	0.20	0.29
MP MB 080 4_216		70	100	250	3200	4500	17'	12'	5.4	89	0.20	0.29
MP MB 080 4_250		70	100	250	4000	6000	17'	12'	5.4	89	0.19	0.28
MP MB 080 4_280		70	100	250	4000	6000	17'	12'	5.4	89	0.19	0.28
MP MB 080 4_350		70	100	250	4000	6000	17'	12'	5.4	89	0.19	0.28
MP MB 080 4_400		70	100	250	4000	6000	17'	12'	5.4	89	0.19	0.28
MP MB 080 4_500		70	100	250	4000	6000	17'	12'	5.4	89	0.19	0.28
MP MB 080 4_700		70	100	250	4000	6000	17'	12'	5.4	89	0.19	0.28
MP MB 080 4_1000		40	80	180	4000	6000	17'	12'	5.4	89	0.19	0.28

MP

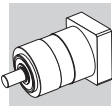

MP 105

IS

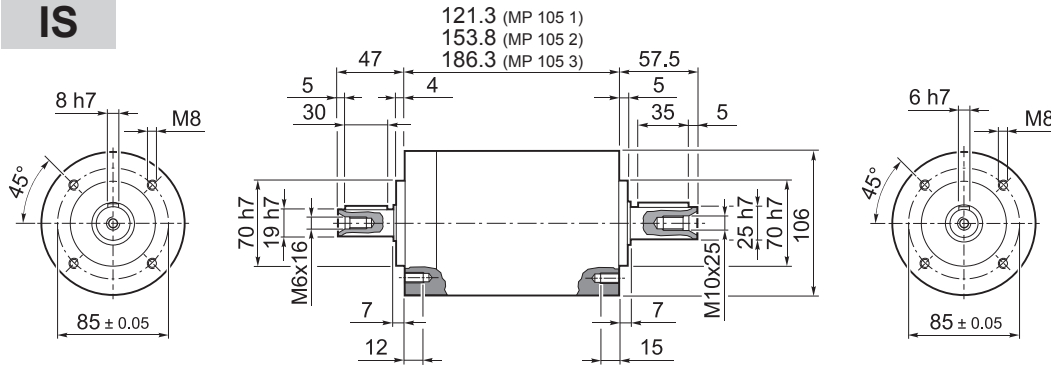

MP 105 1	6.5
MP 105 2	8.5
MP 105 3	10.5

50D ... 130A1

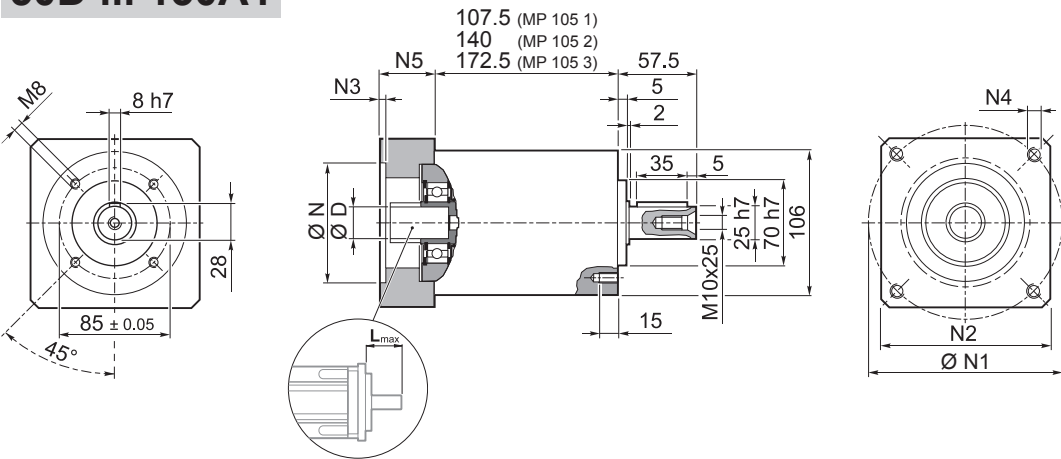

MP 105 1	6.5
MP 105 2	8.5
MP 105 3	10.5

MP

											N	N1	N2	N3	N4	N5	L _{max}
50D	11	12	12.7	14	15	15.875	16	19	-	-	50	95	100	5	M6x14	28	40
55A	11	12	12.7	14	15	15.875	16	19	-	-	55	125.7	105	5	M6x16	28	40
60A2	11	12	12.7	14	15	15.875	16	19	-	-	60	75	100	6.5	M5x14	28	40
60AH2	11	12	12.7	14	15	15.875	16	19	-	-	60	75	100	4	6.5	33	40
60B1	11	12	12.7	14	15	15.875	16	19	-	-	60	85	100	6.5	M5x14	28	40
70A1	11	12	12.7	14	15	15.875	16	19	-	-	70	85	100	6.5	M6x14	28	40
70AH1	11	12	12.7	14	15	15.875	16	19	-	-	70	85	100	4	6.5	33	40
70B1	11	12	12.7	14	15	15.875	16	19	-	-	70	90	100	6.5	M5x12	28	40
80A1	11	12	12.7	14	15	15.875	16	19	-	-	80	100	100	6.5	M6x16	28	40
80AH1	11	12	12.7	14	15	15.875	16	19	-	-	80	100	100	4	6.5	33	40
95A	11	12	12.7	14	15	15.875	16	19	-	-	95	115	100	6.5	M8x18	28	40
95A1	11	12	12.7	14	15	15.875	16	19	22	24	95	115	100	6.5	M8x18	38	50
95B	11	12	12.7	14	15	15.875	16	19	-	-	95	130	115	6.5	M8x18	28	40
110A	11	12	12.7	14	15	15.875	16	19	-	-	110	130	115	6.5	M8x18	28	40
110A1	11	12	12.7	14	15	15.875	16	19	22	24	110	130	115	6.5	M8x20	38	50
110B	11	12	12.7	14	15	15.875	16	19	22	24	110	145	120	6.5	M8x20	38	50
110B1	11	12	12.7	14	15	15.875	16	19	22	24	110	145	120	6.5	M8x20	48	60
130A	11	12	12.7	14	15	15.875	16	19	22	24	130	165	140	6.5	M10x20	38	50
130A1	11	12	12.7	14	15	15.875	16	19	22	24	130	165	140	6.5	M10x25	48	60

Für weitere Motoradapter und Antriebswellenbohrungen bitte nachfragen.

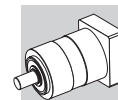

MP 105

FM

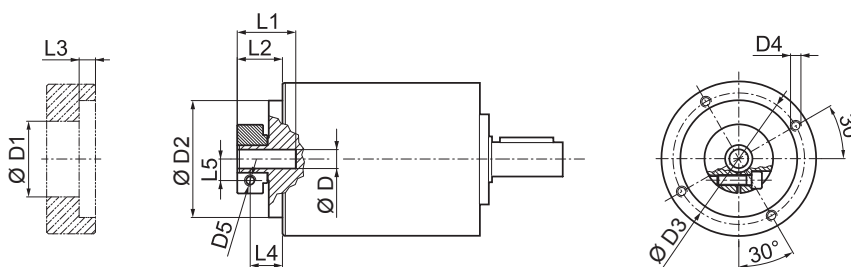

				D1	D2	D3	D4	D5	L1	L2	L3	L4	L5
11	12	12.7		43	90	98	M6x15	M6	31.5	19.5	7.6	12	12.5
14	15	15.875	16	48	90	98	M6x15	M6	31.5	19.5	7.6	12	14.5
19				51	90	98	M6x15	M6	31.5	19.5	7.6	12	16.5
22	24			56.5	90	98	M6x15	M6	35	23	7.6	12	19
28				67	90	98	M6x15	M8	35	23	7.6	14	22.5
32				71	90	98	M6x15	M8	37	25	7.6	16	24.5

	i	M _{n2} [Nm]	M _{a2} [Nm]	M _{p2} [Nm]	n ₁ [min ⁻¹]	n _{1 max} [min ⁻¹]	φ _S [arcmin]	φ _R [arcmin]	C _t [Nm arcmin]	SB				HB		η %	J _G [kgcm ²]			
										R _{1 max} [N]	R _{2 max} [N]	A _{2 max} [N]	R _{2 max} [N]	A _{2 max} [N]						
										11 ... 12.7	14 ... 19	22 - 24	28 - 32							
MP 105 1_3	100	180	360	2500	3500	15'	10'	22.0	600	1500	1600	3800	4000	97	1.70	1.78	2.22	2.59		
MP 105 1_4	140	210	450	2800	4500	15'	10'	22.0	600	1500	1600	3800	4000	97	0.99	1.06	1.51	1.87		
MP 105 1_5	140	210	450	3000	4500	15'	10'	22.0	600	1500	1600	3800	4000	97	0.72	0.79	1.23	1.60		
MP 105 1_6	140	210	450	3000	4500	15'	10'	22.0	600	1500	1600	3800	4000	97	0.36	0.43	0.88	1.24		
MP 105 1_7	140	210	450	3500	5000	15'	10'	22.0	600	1500	1600	3800	4000	97	0.47	0.55	0.99	1.35		
MP 105 1_10	100	180	360	3500	5000	15'	10'	22.0	600	1500	1600	3800	4000	97	0.33	0.41	0.85	1.21		
MP 105 2_9	100	180	360	2500	3500	15'	10'	20.5	600	1500	1600	3800	4000	94	1.58	1.63	2.07	2.44		
MP 105 2_12	170	250	600	2500	3500	15'	10'	20.5	600	1500	1600	3800	4000	94	1.52	1.59	2.03	2.40		
MP 105 2_15	170	250	600	2500	3500	15'	10'	20.5	600	1500	1600	3800	4000	94	1.47	1.55	1.99	2.36		
MP 105 2_16	170	250	600	2800	4500	15'	10'	20.5	600	1500	1600	3800	4000	94	0.87	0.95	1.39	1.76		
MP 105 2_20	170	250	600	3000	4500	15'	10'	20.5	600	1500	1600	3800	4000	94	0.86	0.93	1.37	1.74		
MP 105 2_25	170	250	600	3000	4500	15'	10'	20.5	600	1500	1600	3800	4000	94	0.63	0.71	1.15	1.51		
MP 105 2_28	170	250	600	3500	5000	15'	10'	20.5	600	1500	1600	3800	4000	94	0.43	0.51	0.95	1.32		
MP 105 2_30	100	180	360	3500	5000	15'	10'	20.5	600	1500	1600	3800	4000	94	0.32	0.40	0.84	1.20		
MP 105 2_35	170	250	600	3500	5000	15'	10'	20.5	600	1500	1600	3800	4000	94	0.43	0.50	0.95	1.31		
MP 105 2_36	140	210	450	3000	4500	15'	10'	20.5	600	1500	1600	3800	4000	94	0.32	0.39	0.84	1.20		
MP 105 2_40	170	250	600	3500	5000	15'	10'	20.5	600	1500	1600	3800	4000	94	0.31	0.39	0.83	1.20		
MP 105 2_50	170	250	600	3500	5000	15'	10'	20.5	600	1500	1600	3800	4000	94	0.31	0.39	0.83	1.19		
MP 105 2_70	170	250	600	3500	5000	15'	10'	20.5	600	1500	1600	3800	4000	94	0.31	0.38	0.83	1.19		
MP 105 2_100	100	180	360	3500	5000	15'	10'	20.5	600	1500	1600	3800	4000	94	0.31	0.38	0.83	1.19		
MP 105 3_48	170	250	600	2800	4500	17'	12'	17.5	600	1500	1600	3800	4000	91	0.91	0.98	1.42	1.79		
MP 105 3_64	170	250	600	2800	4500	17'	12'	17.5	600	1500	1600	3800	4000	91	0.87	0.94	1.38	1.75		
MP 105 3_75	170	250	600	3000	4500	17'	12'	17.5	600	1500	1600	3800	4000	91	0.66	0.74	1.18	1.55		
MP 105 3_80	170	250	600	2800	4500	17'	12'	17.5	600	1500	1600	3800	4000	91	0.86	0.94	1.38	1.75		
MP 105 3_84	170	250	600	3500	5000	17'	12'	17.5	600	1500	1600	3800	4000	91	0.44	0.52	0.96	1.33		
MP 105 3_90	100	180	360	3500	5000	17'	12'	17.5	600	1500	1600	3800	4000	91	0.32	0.39	0.84	1.20		
MP 105 3_120	170	250	600	3500	5000	17'	12'	17.5	600	1500	1600	3800	4000	91	0.32	0.39	0.84	1.20		
MP 105 3_125	170	250	600	3000	4500	17'	12'	17.5	600	1500	1600	3800	4000	91	0.63	0.70	1.15	1.51		
MP 105 3_140	170	250	600	3500	5000	17'	12'	17.5	600	1500	1600	3800	4000	91	0.43	0.51	0.95	1.32		
MP 105 3_150	170	250	600	3500	5000	17'	12'	17.5	600	1500	1600	3800	4000	91	0.32	0.39	0.84	1.20		
MP 105 3_160	170	250	600	3500	5000	17'	12'	17.5	600	1500	1600	3800	4000	91	0.31	0.39	0.83	1.21		
MP 105 3_175	170	250	600	3500	5000	17'	12'	17.5	600	1500	1600	3800	4000	91	0.43	0.50	0.95	1.31		
MP 105 3_200	170	250	600	3500	5000	17'	12'	17.5	600	1500	1600	3800	4000	91	0.31	0.39	0.83	1.20		
MP 105 3_210	170	250	600	3500	5000	17'	12'	17.5	600	1500	1600	3800	4000	91	0.32	0.39	0.84	1.20		
MP 105 3_216	170	250	600	3000	4500	17'	12'	17.5	600	1500	1600	3800	4000	91	0.31	0.39	0.83	1.20		
MP 105 3_250	170	250	600	3500	5000	17'	12'	17.5	600	1500	1600	3800	4000	91	0.31	0.39	0.83	1.19		
MP 105 3_280	170	250	600	3500	5000	17'	12'	17.5	600	1500	1600	3800	4000	91	0.31	0.38	0.83	1.19		
MP 105 3_350	170	250	600	3500	5000	17'	12'	17.5	600	1500	1600	3800	4000	91	0.31	0.38	0.83	1.19		
MP 105 3_400	170	250	600	3500	5000	17'	12'	17.5	600	1500	1600	3800	4000	91	0.31	0.38	0.83	1.19		
MP 105 3_500	170	250	600	3500	5000	17'	12'	17.5	600	1500	1600	3800	4000	91	0.31	0.38	0.83	1.19		
MP 105 3_700	170	250	600	3500	5000	17'	12'	17.5	600	1500	1600	3800	4000	91	0.31	0.38	0.83	1.19		
MP 105 3_1000	100	180	360	3500	5000	17'	12'	17.5	600	1500	1600	3800	4000	91	0.31	0.38	0.83	1.19		

MP



MP G 105

50D ... 130A1

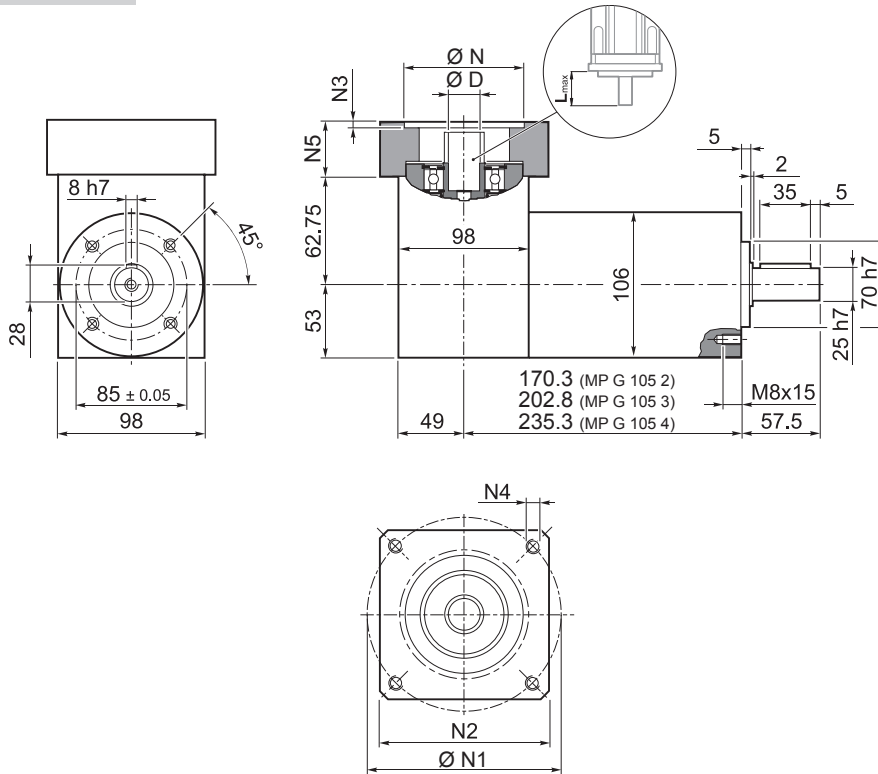

MP G 105 2	8.5
MP G 105 3	10.5
MP G 105 4	12.5

MP

											N	N1	N2	N3	N4	N5	L _{max}		
50D	11	12	12.7	14	15	15.875	16	19	-	-	-	-	50	95	100	5	M6x14	28	40
55A	11	12	12.7	14	15	15.875	16	19	-	-	-	-	55	125.7	105	5	M6x16	28	40
60A2	11	12	12.7	14	15	15.875	16	19	-	-	-	-	60	75	100	6.5	M5x14	28	40
60AH2	11	12	12.7	14	15	15.875	16	19	-	-	-	-	60	75	100	4	6.5	33	40
60B1	11	12	12.7	14	15	15.875	16	19	-	-	-	-	60	85	100	6.5	M5x14	28	40
70A1	11	12	12.7	14	15	15.875	16	19	-	-	-	-	70	85	100	6.5	M6x14	28	40
70AH1	11	12	12.7	14	15	15.875	16	19	-	-	-	-	70	85	100	4	6.5	33	40
70B1	11	12	12.7	14	15	15.875	16	19	-	-	-	-	70	90	100	6.5	M5x12	28	40
80A1	11	12	12.7	14	15	15.875	16	19	-	-	-	-	80	100	100	6.5	M6x16	28	40
80AH1	11	12	12.7	14	15	15.875	16	19	-	-	-	-	80	100	100	4	6.5	33	40
95A	11	12	12.7	14	15	15.875	16	19	-	-	-	-	95	115	100	6.5	M8x18	28	40
95A1	11	12	12.7	14	15	15.875	16	19	22	24	-	-	95	115	100	6.5	M8x18	38	50
95B	11	12	12.7	14	15	15.875	16	19	-	-	-	-	95	130	115	6.5	M8x18	28	40
110A	11	12	12.7	14	15	15.875	16	19	-	-	-	-	110	130	115	6.5	M8x18	28	40
110A1	11	12	12.7	14	15	15.875	16	19	22	24	-	-	110	130	115	6.5	M8x20	38	50
110B	11	12	12.7	14	15	15.875	16	19	22	24	-	-	110	145	120	6.5	M8x20	38	50
110B1	11	12	12.7	14	15	15.875	16	19	22	24	28	-	110	145	120	6.5	M8x20	48	60
130A	11	12	12.7	14	15	15.875	16	19	22	24	-	-	130	165	140	6.5	M10x20	38	50
130A1	11	12	12.7	14	15	15.875	16	19	22	24	28	32	130	165	140	6.5	M10x25	48	60

Für weitere Motoradapter und Antriebswellenbohrungen bitte nachfragen.

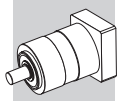

MP G 105

FM

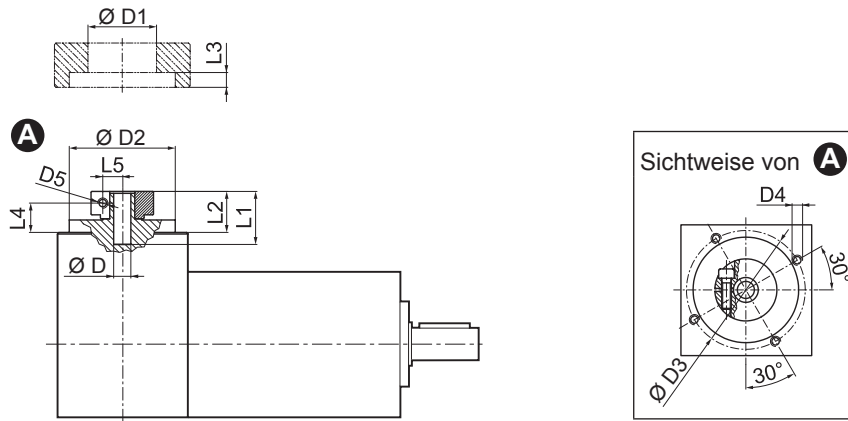

				D1	D2	D3	D4	D5	L1	L2	L3	L4	L5
11	12	12.7		43	90	98	M6x15	M6	31.5	19.5	7.6	12	12.5
14	15	15.875	16	48	90	98	M6x15	M6	31.5	19.5	7.6	12	14.5
19				51	90	98	M6x15	M6	31.5	19.5	7.6	12	16.5
22	24			56.5	90	98	M6x15	M6	35	23	7.6	12	19
28				67	90	98	M6x15	M8	35	23	7.6	14	22.5
32				71	90	98	M6x15	M8	37	25	7.6	16	24.5

	i	M _{n 2} [Nm]	M _{a 2} [Nm]	M _{p 2} [Nm]	n ₁ [min ⁻¹]	n _{1 max} [min ⁻¹]	φ _S [arcmin]	φ _R [arcmin]	C _t [Nm/arcmin]	SB				HB		η %	J _G [kgcm ²]			
										R _{2 max} [N]	A _{2 max} [N]	R _{2 max} [N]	A _{2 max} [N]	11 ... 12.7	14 ... 19		22 - 24	28 - 32		
MP G 105 2_3		100	180	360	2500	3500	15'	10'	22.0	1500	1600	3800	4000	94	1.85	2.01	2.33	3.07		
MP G 105 2_4		140	210	450	2800	4500	15'	10'	22.0	1500	1600	3800	4000	94	1.14	1.29	1.62	2.35		
MP G 105 2_5		140	210	450	3000	4500	15'	10'	22.0	1500	1600	3800	4000	94	1.07	1.21	1.34	2.08		
MP G 105 2_6		140	210	450	3000	4500	15'	10'	22.0	1500	1600	3800	4000	94	0.87	1.02	1.16	1.89		
MP G 105 2_7		140	210	450	3500	5000	15'	10'	22.0	1500	1600	3800	4000	94	0.98	1.14	1.27	2.00		
MP G 105 2_10		100	180	360	3500	5000	15'	10'	22.0	1500	1600	3800	4000	94	0.94	1.09	1.23	1.95		
MP G 105 3_9		100	180	360	2500	3500	15'	10'	20.5	1500	1600	3800	4000	91	1.76	1.86	2.18	2.92		
MP G 105 3_12		170	250	600	2500	3500	15'	10'	20.5	1500	1600	3800	4000	91	1.60	1.75	2.14	2.88		
MP G 105 3_15		170	250	600	2500	3500	15'	10'	20.5	1500	1600	3800	4000	91	1.57	1.73	2.10	2.84		
MP G 105 3_16		170	250	600	2800	4500	15'	10'	20.5	1500	1600	3800	4000	91	1.02	1.18	1.50	2.24		
MP G 105 3_20		170	250	600	3000	4500	15'	10'	20.5	1500	1600	3800	4000	91	1.20	1.35	1.48	2.22		
MP G 105 3_25		170	250	600	3000	4500	15'	10'	20.5	1500	1600	3800	4000	91	1.13	1.29	1.42	2.15		
MP G 105 3_28		170	250	600	3500	5000	15'	10'	20.5	1500	1600	3800	4000	91	0.94	1.10	1.23	1.97		
MP G 105 3_30		100	180	360	3500	5000	15'	10'	20.5	1500	1600	3800	4000	91	0.93	1.08	1.22	1.94		
MP G 105 3_35		170	250	600	3500	5000	15'	10'	20.5	1500	1600	3800	4000	91	1.02	1.17	1.31	2.04		
MP G 105 3_36		140	210	450	3000	4500	15'	10'	20.5	1500	1600	3800	4000	91	0.83	0.98	1.12	1.85		
MP G 105 3_40		170	250	600	3500	5000	15'	10'	20.5	1500	1600	3800	4000	91	0.96	1.11	1.25	1.98		
MP G 105 3_50		170	250	600	3500	5000	15'	10'	20.5	1500	1600	3800	4000	91	0.96	1.11	1.25	1.98		
MP G 105 3_70		170	250	600	3500	5000	15'	10'	20.5	1500	1600	3800	4000	91	0.92	1.06	1.21	1.93		
MP G 105 3_100		100	180	360	3500	5000	15'	10'	20.5	1500	1600	3800	4000	91	0.92	1.06	1.21	1.93		
MP G 105 4_48		170	250	600	2800	4500	17'	12'	17.5	1500	1600	3800	4000	89	1.06	1.21	1.53	2.27		
MP G 105 4_64		170	250	600	2800	4500	17'	12'	17.5	1500	1600	3800	4000	89	1.02	1.17	1.49	2.23		
MP G 105 4_75		170	250	600	3000	4500	17'	12'	17.5	1500	1600	3800	4000	89	1.00	1.16	1.29	2.03		
MP G 105 4_80		170	250	600	2800	4500	17'	12'	17.5	1500	1600	3800	4000	89	1.01	1.17	1.49	2.23		
MP G 105 4_84		170	250	600	3500	5000	17'	12'	17.5	1500	1600	3800	4000	89	0.95	1.11	1.24	1.98		
MP G 105 4_90		100	180	360	3500	5000	17'	12'	17.5	1500	1600	3800	4000	89	0.93	1.07	1.22	1.94		
MP G 105 4_120		170	250	600	3500	5000	17'	12'	17.5	1500	1600	3800	4000	89	0.93	1.07	1.22	1.94		
MP G 105 4_125		170	250	600	3000	4500	17'	12'	17.5	1500	1600	3800	4000	89	0.97	1.12	1.26	1.99		
MP G 105 4_140		170	250	600	3500	5000	17'	12'	17.5	1500	1600	3800	4000	89	0.94	1.10	1.23	1.97		
MP G 105 4_150		170	250	600	3500	5000	17'	12'	17.5	1500	1600	3800	4000	89	0.93	1.07	1.22	1.94		
MP G 105 4_160		170	250	600	3500	5000	17'	12'	17.5	1500	1600	3800	4000	89	0.92	1.07	1.21	1.96		
MP G 105 4_175		170	250	600	3500	5000	17'	12'	17.5	1500	1600	3800	4000	89	0.94	1.09	1.23	1.96		
MP G 105 4_200		170	250	600	3500	5000	17'	12'	17.5	1500	1600	3800	4000	89	0.92	1.07	1.21	1.94		
MP G 105 4_210		170	250	600	3500	5000	17'	12'	17.5	1500	1600	3800	4000	89	0.93	1.07	1.22	1.94		
MP G 105 4_216		170	250	600	3000	4500	17'	12'	17.5	1500	1600	3800	4000	89	0.83	0.98	1.11	1.85		
MP G 105 4_250		170	250	600	3500	5000	17'	12'	17.5	1500	1600	3800	4000	89	0.92	1.07	1.21	1.93		
MP G 105 4_280		170	250	600	3500	5000	17'	12'	17.5	1500	1600	3800	4000	89	0.92	1.06	1.21	1.93		
MP G 105 4_350		170	250	600	3500	5000	17'	12'	17.5	1500	1600	3800	4000	89	0.92	1.06	1.21	1.93		
MP G 105 4_400		170	250	600	3500	5000	17'	12'	17.5	1500	1600	3800	4000	89	0.92	1.06	1.21	1.93		
MP G 105 4_500		170	250	600	3500	5000	17'	12'	17.5	1500	1600	3800	4000	89	0.92	1.06	1.21	1.93		
MP G 105 4_700		170	250	600	3500	5000	17'	12'	17.5	1500	1600	3800	4000	89	0.92	1.06	1.21	1.93		
MP G 105 4_1000		100	180	360	3500	5000	17'	12'	17.5	1500	1600	3800	4000	89	0.92	1.06	1.21	1.93		

MP



MP MB 105

50D ... 130A1

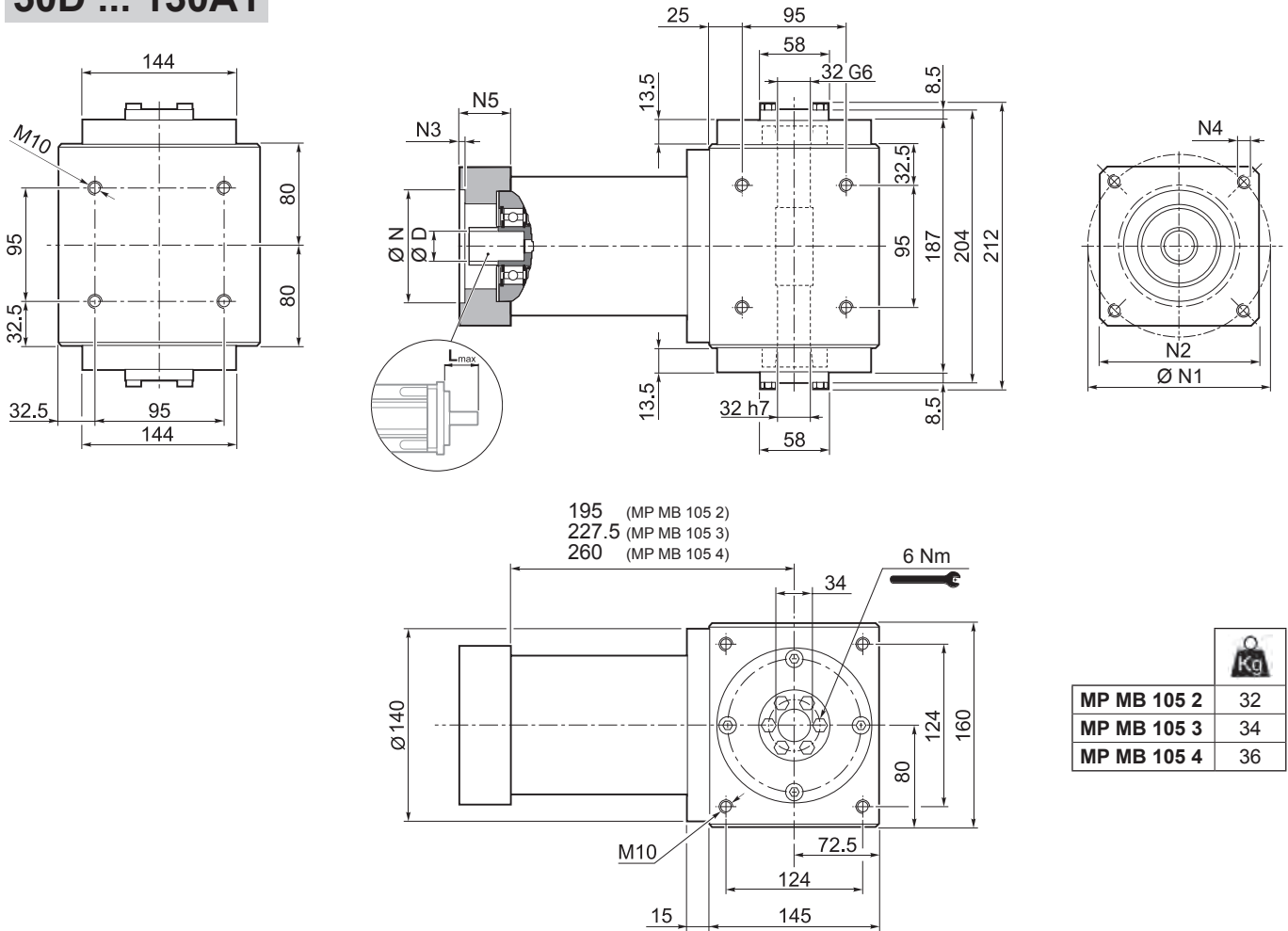

MP

Motor Adapter	D											N	N1	N2	N3	N4	N5	Lmax
	11	12	12.7	14	15	15.875	16	19	-	-	-							
50D	11	12	12.7	14	15	15.875	16	19	-	-	-	50	95	100	5	M6x14	28	40
55A	11	12	12.7	14	15	15.875	16	19	-	-	-	55	125.7	105	5	M6x16	28	40
60A2	11	12	12.7	14	15	15.875	16	19	-	-	-	60	75	100	6.5	M5x14	28	40
60AH2	11	12	12.7	14	15	15.875	16	19	-	-	-	60	75	100	4	6.5	33	40
60B1	11	12	12.7	14	15	15.875	16	19	-	-	-	60	85	100	6.5	M5x14	28	40
70A1	11	12	12.7	14	15	15.875	16	19	-	-	-	70	85	100	6.5	M6x14	28	40
70AH1	11	12	12.7	14	15	15.875	16	19	-	-	-	70	85	100	4	6.5	33	40
70B1	11	12	12.7	14	15	15.875	16	19	-	-	-	70	90	100	6.5	M5x12	28	40
80A1	11	12	12.7	14	15	15.875	16	19	-	-	-	80	100	100	6.5	M6x16	28	40
80AH1	11	12	12.7	14	15	15.875	16	19	-	-	-	80	100	100	4	6.5	33	40
95A	11	12	12.7	14	15	15.875	16	19	-	-	-	95	115	100	6.5	M8x18	28	40
95A1	11	12	12.7	14	15	15.875	16	19	22	24	-	95	115	100	6.5	M8x18	38	50
95B	11	12	12.7	14	15	15.875	16	19	-	-	-	95	130	115	6.5	M8x18	28	40
110A	11	12	12.7	14	15	15.875	16	19	-	-	-	110	130	115	6.5	M8x18	28	40
110A1	11	12	12.7	14	15	15.875	16	19	22	24	-	110	130	115	6.5	M8x20	38	50
110B	11	12	12.7	14	15	15.875	16	19	22	24	-	110	145	120	6.5	M8x20	38	50
110B1	11	12	12.7	14	15	15.875	16	19	22	24	28	110	145	120	6.5	M8x20	48	60
130A	11	12	12.7	14	15	15.875	16	19	22	24	-	130	165	140	6.5	M10x20	38	50
130A1	11	12	12.7	14	15	15.875	16	19	22	24	28	130	165	140	6.5	M10x25	48	60

Für weitere Motoradapter und Antriebswellenbohrungen bitte nachfragen.

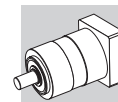

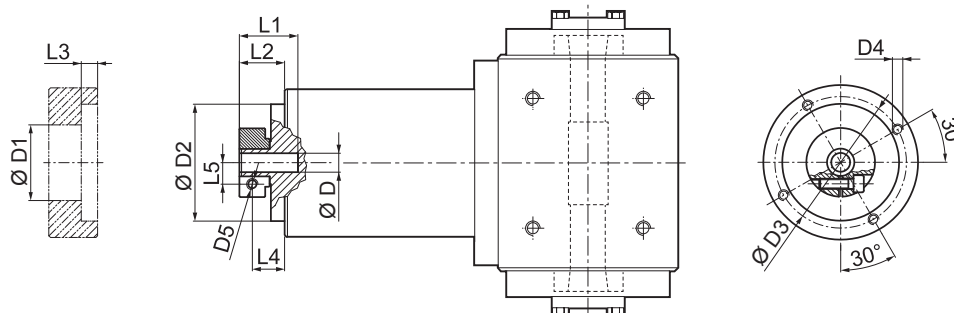

MP MB 105

FM

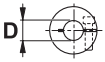

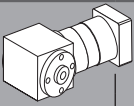
				D1	D2	D3	D4	D5	L1	L2	L3	L4	L5
11	12	12.7		43	90	98	M6x15	M6	31.5	19.5	7.6	12	12.5
14	15	15.875	16	48	90	98	M6x15	M6	31.5	19.5	7.6	12	14.5
19				51	90	98	M6x15	M6	31.5	19.5	7.6	12	16.5
22	24			56.5	90	98	M6x15	M6	35	23	7.6	12	19
28				67	90	98	M6x15	M8	35	23	7.6	14	22.5
32				71	90	98	M6x15	M8	37	25	7.6	16	24.5

	i	M _{n 2} [Nm]	M _{a 2} [Nm]	M _{p 2} [Nm]	n ₁ [min ⁻¹]	n _{1 max} [min ⁻¹]	φ _S [arcmin]	φ _R [arcmin]	C _t [Nm / arcmin]	η %	J _G [kgcm ²]			
														
											11 ... 12.7	14 ... 19	22 - 24	28 - 32
MP MB 105 2_3	100	180	360	2500	3500	15'	10'	22.0	94	1.70	1.78	2.22	2.59	
MP MB 105 2_4	140	210	450	2800	4500	15'	10'	22.0	94	0.99	1.06	1.51	1.87	
MP MB 105 2_5	140	210	450	3000	4500	15'	10'	22.0	94	0.72	0.79	1.23	1.60	
MP MB 105 2_6	140	210	450	3000	4500	15'	10'	22.0	94	0.36	0.43	0.88	1.24	
MP MB 105 2_7	140	210	450	3500	5000	15'	10'	22.0	94	0.47	0.55	0.99	1.35	
MP MB 105 2_10	100	180	360	3500	5000	15'	10'	22.0	94	0.33	0.41	0.85	1.21	
MP MB 105 3_9	100	180	360	2500	3500	15'	10'	20.5	91	1.58	1.63	2.07	2.44	
MP MB 105 3_12	170	250	600	2500	3500	15'	10'	20.5	91	1.52	1.59	2.03	2.40	
MP MB 105 3_15	170	250	600	2500	3500	15'	10'	20.5	91	1.47	1.55	1.99	2.36	
MP MB 105 3_16	170	250	600	2800	4500	15'	10'	20.5	91	0.87	0.95	1.39	1.76	
MP MB 105 3_20	170	250	600	3000	4500	15'	10'	20.5	91	0.86	0.93	1.37	1.74	
MP MB 105 3_25	170	250	600	3000	4500	15'	10'	20.5	91	0.63	0.71	1.15	1.51	
MP MB 105 3_28	170	250	600	3500	5000	15'	10'	20.5	91	0.43	0.51	0.95	1.32	
MP MB 105 3_30	100	180	360	3500	5000	15'	10'	20.5	91	0.32	0.40	0.84	1.20	
MP MB 105 3_35	170	250	600	3500	5000	15'	10'	20.5	91	0.43	0.50	0.95	1.31	
MP MB 105 3_36	140	210	450	3000	4500	15'	10'	20.5	91	0.32	0.39	0.84	1.20	
MP MB 105 3_40	170	250	600	3500	5000	15'	10'	20.5	91	0.31	0.39	0.83	1.20	
MP MB 105 3_50	170	250	600	3500	5000	15'	10'	20.5	91	0.31	0.39	0.83	1.19	
MP MB 105 3_70	170	250	600	3500	5000	15'	10'	20.5	91	0.31	0.38	0.83	1.19	
MP MB 105 3_100	100	180	360	3500	5000	15'	10'	20.5	91	0.31	0.38	0.83	1.19	
MP MB 105 4_48	170	250	600	2800	4500	17'	12'	17.5	89	0.91	0.98	1.42	1.79	
MP MB 105 4_64	170	250	600	2800	4500	17'	12'	17.5	89	0.87	0.94	1.38	1.75	
MP MB 105 4_75	170	250	600	3000	4500	17'	12'	17.5	89	0.66	0.74	1.18	1.55	
MP MB 105 4_80	170	250	600	2800	4500	17'	12'	17.5	89	0.86	0.94	1.38	1.75	
MP MB 105 4_84	170	250	600	3500	5000	17'	12'	17.5	89	0.44	0.52	0.96	1.33	
MP MB 105 4_90	100	180	360	3500	5000	17'	12'	17.5	89	0.32	0.39	0.84	1.20	
MP MB 105 4_120	170	250	600	3500	5000	17'	12'	17.5	89	0.32	0.39	0.84	1.20	
MP MB 105 4_125	170	250	600	3000	4500	17'	12'	17.5	89	0.63	0.70	1.15	1.51	
MP MB 105 4_140	170	250	600	3500	5000	17'	12'	17.5	89	0.43	0.51	0.95	1.32	
MP MB 105 4_150	170	250	600	3500	5000	17'	12'	17.5	89	0.32	0.39	0.84	1.20	
MP MB 105 4_160	170	250	600	3500	5000	17'	12'	17.5	89	0.31	0.39	0.83	1.21	
MP MB 105 4_175	170	250	600	3500	5000	17'	12'	17.5	89	0.43	0.50	0.95	1.31	
MP MB 105 4_200	170	250	600	3500	5000	17'	12'	17.5	89	0.31	0.39	0.83	1.20	
MP MB 105 4_210	170	250	600	3500	5000	17'	12'	17.5	89	0.32	0.39	0.84	1.20	
MP MB 105 4_216	170	250	600	3000	4500	17'	12'	17.5	89	0.31	0.39	0.83	1.20	
MP MB 105 4_250	170	250	600	3500	5000	17'	12'	17.5	89	0.31	0.39	0.83	1.19	
MP MB 105 4_280	170	250	600	3500	5000	17'	12'	17.5	89	0.31	0.38	0.83	1.19	
MP MB 105 4_350	170	250	600	3500	5000	17'	12'	17.5	89	0.31	0.38	0.83	1.19	
MP MB 105 4_400	170	250	600	3500	5000	17'	12'	17.5	89	0.31	0.38	0.83	1.19	
MP MB 105 4_500	170	250	600	3500	5000	17'	12'	17.5	89	0.31	0.38	0.83	1.19	
MP MB 105 4_700	170	250	600	3500	5000	17'	12'	17.5	89	0.31	0.38	0.83	1.19	
MP MB 105 4_1000	100	180	360	3500	5000	17'	12'	17.5	89	0.31	0.38	0.83	1.19	

MP



MP 130

IS

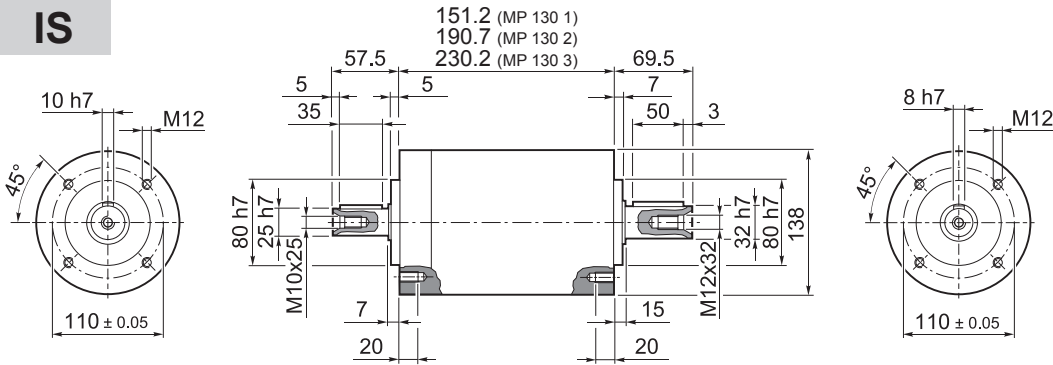

MP 130 1	12.0
MP 130 2	15.5
MP 130 3	18.5

55A1 ... 180A1

MP

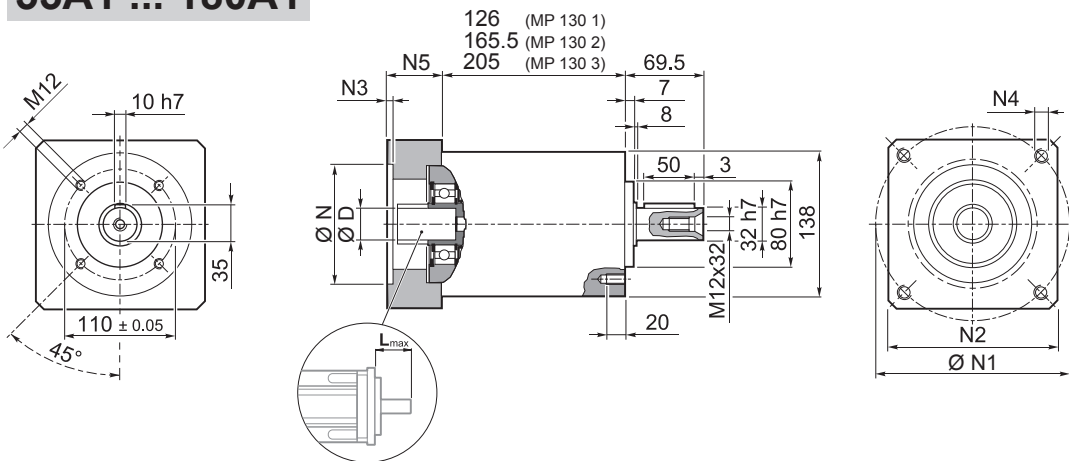

MP 130 1	12.0
MP 130 2	15.5
MP 130 3	18.5

											N	N1	N2	N3	N4	N5	L _{max}
55A1	14	15.875	16	19	-	-	-	-	-	-	55.5	125.7	130	4	M6x15	39.5	50
80A2	14	15.875	16	19	-	-	-	-	-	-	80	100	130	4	M6x15	39.5	50
95A1	14	15.875	16	19	22	24	-	-	-	-	95	115	130	4	M8x20	39.5	50
110A1	14	15.875	16	19	22	24	-	-	-	-	110	130	130	4	M8x20	39.5	50
110B1	14	15.875	16	19	22	24	-	-	-	-	110	145	130	6.5	M8x20	49.5	60
114A0	14	15.875	16	19	22	24	-	-	-	-	114.3	200	170	5.5	M12x25	39.5	50
114A	14	15.875	16	19	22	24	28	32	35	38	114.3	200	170	5.5	M12x25	69.5	80
130A	14	15.875	16	19	22	24	-	-	-	-	130	165	140	4	M10x20	39.5	50
130A1	14	15.875	16	19	22	24	28	32	-	-	130	165	140	4	M10x20	49.5	60
180A	14	15.875	16	19	22	24	28	32	-	-	180	215	190	5.5	M14x25	49.5	60
180A1	14	15.875	16	19	22	24	28	32	35	38	180	215	190	5.5	M14x25	69.5	80

Für weitere Motoradapter und Antriebswellenbohrungen bitte nachfragen.

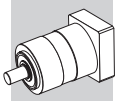

MP 130

FM

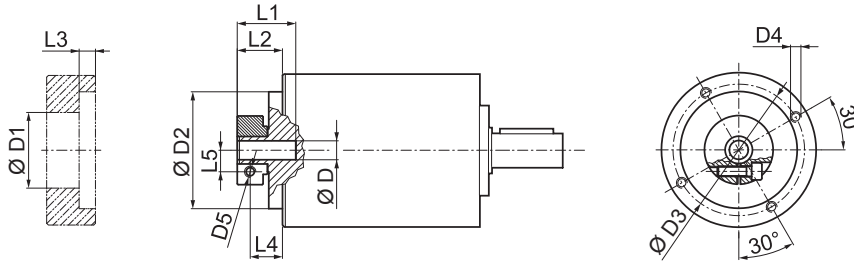

D			D1	D2	D3	D4	D5	L1	L2	L3	L4	L5
14	15.875	16	48	113	125.5	M8x15	M6	40	27.5	6	20	14.5
19			51	113	125.5	M8x15	M6	40	27.5	6	20	16.5
22	24		56.5	113	125.5	M8x15	M6	41	28.5	6	19.5	19
28			67	113	125.5	M8x15	M8	41	28.5	6	19.5	22.5
32			71	113	125.5	M8x15	M8	41	28.5	6	19.5	24.5
35			73	113	125.5	M8x15	M8	50	37.5	11.25	26	26
38			77.5	113	125.5	M8x15	M8	50	37.5	11.25	26	28

i	M_{n2} [Nm]	M_{a2} [Nm]	M_{p2} [Nm]	n_1 [min ⁻¹]	n_{1max} [min ⁻¹]	φ_S [arcmin]	φ_R	C_t [$\frac{Nm}{arcmin}$]	R_{1max} [N]	R_{2max} [N]	A_{2max} [N]	η %	J_G [kgcm ²]			
													D	14 ... 19	22 - 24	28 - 32
MP 130 1_3	215	400	800	2100	3000	15'	10'	43.0	800	5500	6500	97	5.25	5.46	5.81	7.16
MP 130 1_4	380	600	1100	2400	3500	15'	10'	43.0	800	5500	6500	97	3.06	3.26	3.61	4.97
MP 130 1_5	380	600	1100	2900	3500	15'	10'	43.0	800	5500	6500	97	2.22	2.42	2.77	4.13
MP 130 1_6	380	600	1100	2900	3500	15'	10'	43.0	800	5500	6500	97	1.19	1.40	1.75	3.10
MP 130 1_7	380	600	1100	3200	4000	15'	10'	43.0	800	5500	6500	97	1.47	1.68	2.03	3.38
MP 130 1_10	215	400	800	3200	4000	15'	10'	43.0	800	5500	6500	97	1.04	1.25	1.60	2.95
MP 130 2_9	215	400	800	2100	3000	15'	10'	37.5	800	5500	6500	94	4.82	5.02	5.37	6.72
MP 130 2_12	450	700	1300	2100	3000	15'	10'	37.5	800	5500	6500	94	4.57	4.78	5.13	6.48
MP 130 2_15	450	700	1300	2100	3000	15'	10'	37.5	800	5500	6500	94	4.48	4.69	5.04	6.39
MP 130 2_16	450	700	1300	2400	3500	15'	10'	37.5	800	5500	6500	94	2.67	2.88	3.23	4.58
MP 130 2_20	450	700	1300	2900	3500	15'	10'	37.5	800	5500	6500	94	1.97	2.18	2.53	3.88
MP 130 2_25	450	700	1300	2900	3500	15'	10'	37.5	800	5500	6500	94	1.94	2.15	2.50	3.85
MP 130 2_28	450	700	1300	3200	4000	15'	10'	37.5	800	5500	6500	94	1.34	1.55	1.90	3.25
MP 130 2_30	215	400	800	3200	4000	15'	10'	37.5	800	5500	6500	94	1.00	1.21	1.56	2.91
MP 130 2_35	450	700	1300	3200	4000	15'	10'	37.5	800	5500	6500	94	1.33	1.53	1.88	3.24
MP 130 2_36	380	600	1100	2900	3500	15'	10'	37.5	800	5500	6500	94	1.05	1.26	1.61	2.96
MP 130 2_40	450	700	1300	3200	4000	15'	10'	37.5	800	5500	6500	94	0.98	1.19	1.54	2.89
MP 130 2_50	450	700	1300	3200	4000	15'	10'	37.5	800	5500	6500	94	0.97	1.18	1.53	2.88
MP 130 2_70	450	700	1300	3200	4000	15'	10'	37.5	800	5500	6500	94	0.96	1.17	1.52	2.87
MP 130 2_100	215	400	800	3200	4000	15'	10'	37.5	800	5500	6500	94	0.96	1.17	1.52	2.87
MP 130 3_48	450	700	1300	2400	3500	17'	12'	29.5	800	5500	6500	91	2.77	2.98	3.33	4.68
MP 130 3_64	450	700	1300	2400	3500	17'	12'	29.5	800	5500	6500	91	2.65	2.86	3.21	4.56
MP 130 3_75	450	700	1300	2900	3500	17'	12'	29.5	800	5500	6500	91	2.03	2.24	2.59	3.94
MP 130 3_80	450	700	1300	2400	3500	17'	12'	29.5	800	5500	6500	91	2.65	2.85	3.20	4.56
MP 130 3_84	450	700	1300	3200	4000	17'	12'	29.5	800	5500	6500	91	1.37	1.58	1.93	3.28
MP 130 3_90	215	400	800	3200	4000	17'	12'	29.5	800	5500	6500	91	1.00	1.20	1.55	2.91
MP 130 3_120	450	700	1300	3200	4000	17'	12'	29.5	800	5500	6500	91	0.99	1.20	1.55	2.90
MP 130 3_125	450	700	1300	2900	3500	17'	12'	29.5	800	5500	6500	91	1.93	2.13	2.48	3.84
MP 130 3_140	450	700	1300	3200	4000	17'	12'	29.5	800	5500	6500	91	1.34	1.54	1.89	3.25
MP 130 3_150	450	700	1300	3200	4000	17'	12'	29.5	800	5500	6500	91	0.99	1.20	1.55	2.90
MP 130 3_160	450	700	1300	3200	4000	17'	12'	29.5	800	5500	6500	91	0.98	1.18	1.53	2.89
MP 130 3_175	450	700	1300	3200	4000	17'	12'	29.5	800	5500	6500	91	1.32	1.53	1.88	3.23
MP 130 3_200	450	700	1300	3200	4000	17'	12'	29.5	800	5500	6500	91	0.97	1.18	1.53	2.88
MP 130 3_210	450	700	1300	3200	4000	17'	12'	29.5	800	5500	6500	91	0.99	1.20	1.55	2.90
MP 130 3_216	450	700	1300	2900	3500	17'	12'	29.5	800	5500	6500	91	1.05	1.26	1.61	2.96
MP 130 3_250	450	700	1300	3200	4000	17'	12'	29.5	800	5500	6500	91	0.97	1.18	1.53	2.88
MP 130 3_280	450	700	1300	3200	4000	17'	12'	29.5	800	5500	6500	91	0.96	1.17	1.52	2.87
MP 130 3_350	450	700	1300	3200	4000	17'	12'	29.5	800	5500	6500	91	0.96	1.17	1.52	2.87
MP 130 3_400	450	700	1300	3200	4000	17'	12'	29.5	800	5500	6500	91	0.96	1.17	1.52	2.87
MP 130 3_500	450	700	1300	3200	4000	17'	12'	29.5	800	5500	6500	91	0.96	1.17	1.52	2.87
MP 130 3_700	450	700	1300	3200	4000	17'	12'	29.5	800	5500	6500	91	0.96	1.17	1.52	2.87
MP 130 3_1000	215	400	800	3200	4000	17'	12'	29.5	800	5500	6500	91	0.96	1.17	1.52	2.87

MP



MP G 130

55A1 ... 180A1

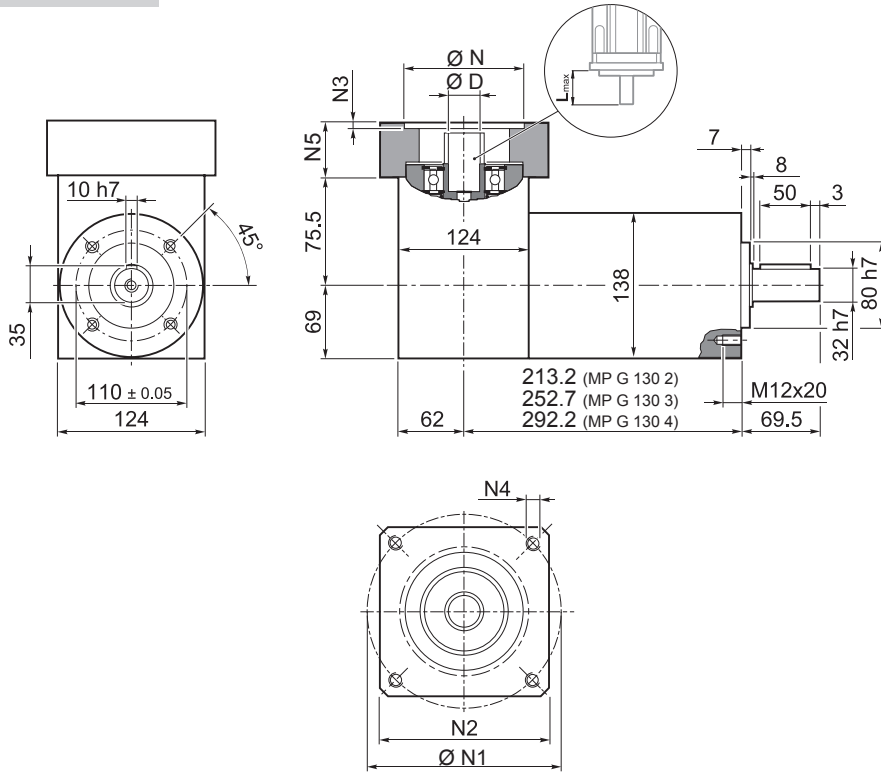

	Kg
MP G 130 2	16.0
MP G 130 3	19.5
MP G 130 4	22.5

MP

											N	N1	N2	N3	N4	N5	L _{max}
55A1	14	15.875	16	19	-	-	-	-	-	-	55.5	125.7	130	4	M6x15	39.5	50
80A2	14	15.875	16	19	-	-	-	-	-	-	80	100	130	4	M6x15	39.5	50
95A1	14	15.875	16	19	22	24	-	-	-	-	95	115	130	4	M8x20	39.5	50
110A1	14	15.875	16	19	22	24	-	-	-	-	110	130	130	4	M8x20	39.5	50
110B1	14	15.875	16	19	22	24	-	-	-	-	110	145	130	6.5	M8x20	49.5	60
114A0	14	15.875	16	19	22	24	-	-	-	-	114.3	200	170	5.5	M12x25	39.5	50
114A	14	15.875	16	19	22	24	28	32	35	38	114.3	200	170	5.5	M12x25	69.5	80
130A	14	15.875	16	19	22	24	-	-	-	-	130	165	140	4	M10x20	39.5	50
130A1	14	15.875	16	19	22	24	28	32	-	-	130	165	140	4	M10x20	49.5	60
180A	14	15.875	16	19	22	24	28	32	-	-	180	215	190	5.5	M14x25	49.5	60
180A1	14	15.875	16	19	22	24	28	32	35	38	180	215	190	5.5	M14x25	69.5	80

Für weitere Motoradapter und Antriebswellenbohrungen bitte nachfragen.

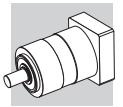

MP G 130

FM

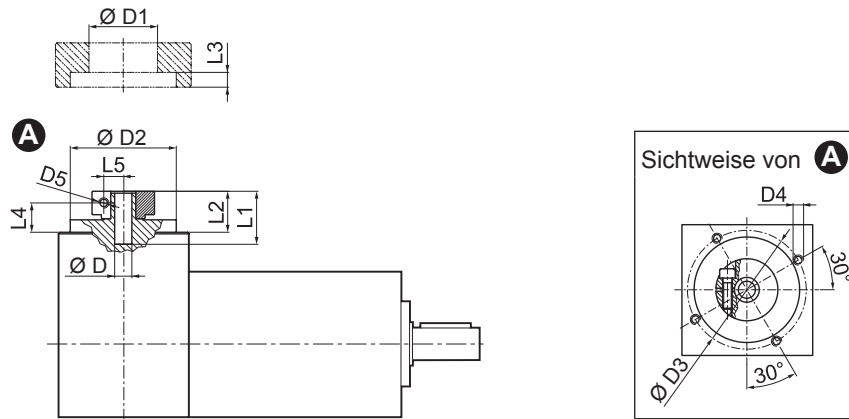

			D1	D2	D3	D4	D5	L1	L2	L3	L4	L5
14	15.875	16	48	113	125.5	M8x15	M6	40	27.5	6	20	14.5
19			51	113	125.5	M8x15	M6	40	27.5	6	20	16.5
22	24		56.5	113	125.5	M8x15	M6	41	28.5	6	19.5	19
28			67	113	125.5	M8x15	M8	41	28.5	6	19.5	22.5
32			71	113	125.5	M8x15	M8	41	28.5	6	19.5	24.5
35			73	113	125.5	M8x15	M8	50	37.5	11.25	26	26
38			77.5	113	125.5	M8x15	M8	50	37.5	11.25	26	28

	i	M _{n 2} [Nm]	M _{a 2} [Nm]	M _{p 2} [Nm]	n ₁ [min ⁻¹]	n _{1 max} [min ⁻¹]	ϕ _S [arcmin]	ϕ _R [arcmin]	C _t [Nm arcmin]	R _{2 max} [N]	A _{2 max} [N]	η %	J _G [kgcm ²]			
														14 ... 19	22 - 24	28 - 32
MP G 130 2_3		215	400	800	2100	3000	15'	10'	43.0	5500	6500	94	7.09	7.28	7.66	10.37
MP G 130 2_4		380	600	1100	2400	3500	15'	10'	43.0	5500	6500	94	4.90	5.08	5.46	8.18
MP G 130 2_5		380	600	1100	2900	3500	15'	10'	43.0	5500	6500	94	4.81	4.99	5.38	8.10
MP G 130 2_6		380	600	1100	2900	3500	15'	10'	43.0	5500	6500	94	4.45	4.64	5.03	7.73
MP G 130 2_7		380	600	1100	3200	4000	15'	10'	43.0	5500	6500	94	4.73	4.92	5.31	8.01
MP G 130 2_10		215	400	800	3200	4000	15'	10'	43.0	5500	6500	94	4.68	4.88	5.26	7.97
MP G 130 3_9		215	400	800	2100	3000	15'	10'	37.5	5500	6500	91	6.66	6.84	7.22	9.93
MP G 130 3_12		450	700	1300	2100	3000	15'	10'	37.5	5500	6500	91	6.25	6.45	6.84	9.54
MP G 130 3_15		450	700	1300	2100	3000	15'	10'	37.5	5500	6500	91	6.25	6.44	6.83	9.53
MP G 130 3_16		450	700	1300	2400	3500	15'	10'	37.5	5500	6500	91	4.51	4.70	5.08	7.79
MP G 130 3_20		450	700	1300	2900	3500	15'	10'	37.5	5500	6500	91	4.56	5.36	5.75	8.45
MP G 130 3_25		450	700	1300	2900	3500	15'	10'	37.5	5500	6500	91	5.13	4.72	5.11	7.82
MP G 130 3_28		450	700	1300	3200	4000	15'	10'	37.5	5500	6500	91	4.60	4.79	5.18	7.88
MP G 130 3_30		215	400	800	3200	4000	15'	10'	37.5	5500	6500	91	4.64	4.84	5.22	7.93
MP G 130 3_35		450	700	1300	3200	4000	15'	10'	37.5	5500	6500	91	4.92	5.10	5.49	8.20
MP G 130 3_36		380	600	1100	2900	3500	15'	10'	37.5	5500	6500	91	4.31	4.50	4.89	7.59
MP G 130 3_40		450	700	1300	3200	4000	15'	10'	37.5	5500	6500	91	4.77	4.96	5.35	8.05
MP G 130 3_50		450	700	1300	3200	4000	15'	10'	37.5	5500	6500	91	4.76	4.96	5.34	8.05
MP G 130 3_70		450	700	1300	3200	4000	15'	10'	37.5	5500	6500	91	4.60	4.80	5.18	7.89
MP G 130 3_100		215	400	800	3200	4000	15'	10'	37.5	5500	6500	91	4.60	4.80	5.18	7.89
MP G 130 4_48		450	700	1300	2400	3500	17'	12'	29.5	5500	6500	89	4.61	4.81	5.18	7.89
MP G 130 4_64		450	700	1300	2400	3500	17'	12'	29.5	5500	6500	89	4.49	4.68	5.06	7.77
MP G 130 4_75		450	700	1300	2900	3500	17'	12'	29.5	5500	6500	89	4.62	4.81	5.20	7.91
MP G 130 4_80		450	700	1300	2400	3500	17'	12'	29.5	5500	6500	89	4.49	4.67	5.05	7.77
MP G 130 4_84		450	700	1300	3200	4000	17'	12'	29.5	5500	6500	89	4.63	4.82	5.21	7.91
MP G 130 4_90		215	400	800	3200	4000	17'	12'	29.5	5500	6500	89	4.64	4.83	5.21	7.93
MP G 130 4_120		450	700	1300	3200	4000	17'	12'	29.5	5500	6500	89	4.63	4.83	5.21	7.92
MP G 130 4_125		450	700	1300	2900	3500	17'	12'	29.5	5500	6500	89	4.52	4.70	5.09	7.81
MP G 130 4_140		450	700	1300	3200	4000	17'	12'	29.5	5500	6500	89	4.60	4.78	5.17	7.88
MP G 130 4_150		450	700	1300	3200	4000	17'	12'	29.5	5500	6500	89	4.63	4.83	5.21	7.92
MP G 130 4_160		450	700	1300	3200	4000	17'	12'	29.5	5500	6500	89	4.62	4.81	5.19	7.91
MP G 130 4_175		450	700	1300	3200	4000	17'	12'	29.5	5500	6500	89	4.58	4.77	5.16	7.86
MP G 130 4_200		450	700	1300	3200	4000	17'	12'	29.5	5500	6500	89	4.61	4.81	5.19	7.90
MP G 130 4_210		450	700	1300	3200	4000	17'	12'	29.5	5500	6500	89	4.63	4.83	5.21	7.92
MP G 130 4_216		450	700	1300	2900	3500	17'	12'	29.5	5500	6500	89	4.31	4.50	4.89	7.59
MP G 130 4_250		450	700	1300	3200	4000	17'	12'	29.5	5500	6500	89	4.61	4.81	5.19	7.90
MP G 130 4_280		450	700	1300	3200	4000	17'	12'	29.5	5500	6500	89	4.60	4.80	5.18	7.89
MP G 130 4_350		450	700	1300	3200	4000	17'	12'	29.5	5500	6500	89	4.60	4.80	5.18	7.89
MP G 130 4_400		450	700	1300	3200	4000	17'	12'	29.5	5500	6500	89	4.60	4.80	5.18	7.89
MP G 130 4_500		450	700	1300	3200	4000	17'	12'	29.5	5500	6500	89	4.60	4.80	5.18	7.89
MP G 130 4_700		450	700	1300	3200	4000	17'	12'	29.5	5500	6500	89	4.60	4.80	5.18	7.89
MP G 130 4_1000		215	400	800	3200	4000	17'	12'	29.5	5500	6500	89	4.60	4.80	5.18	7.89

MP



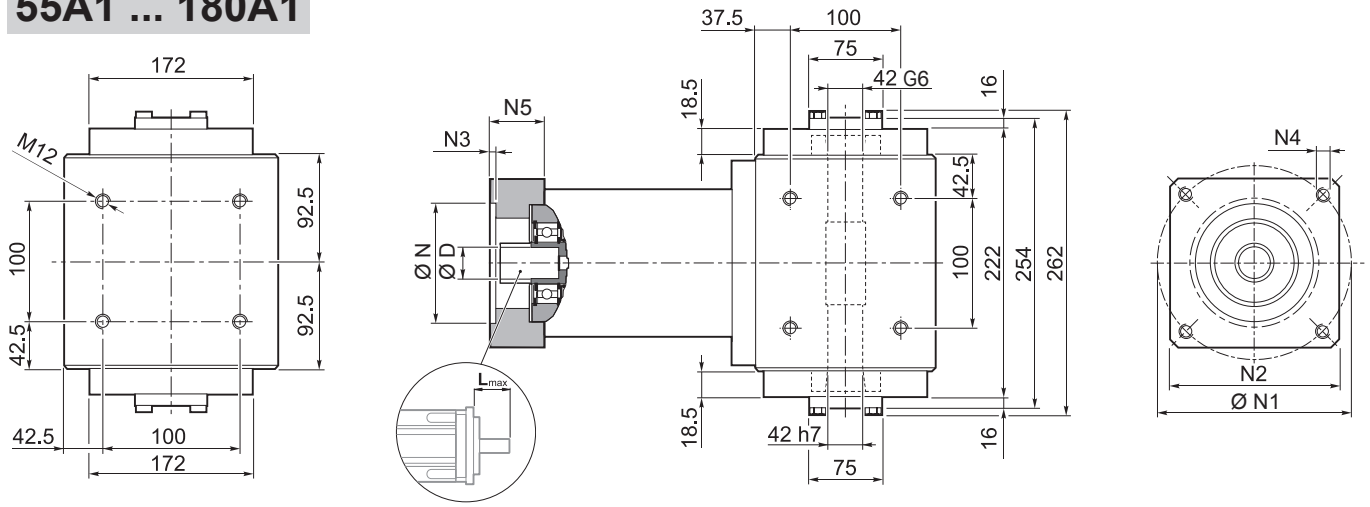

MP MB 130

55A1 ... 180A1



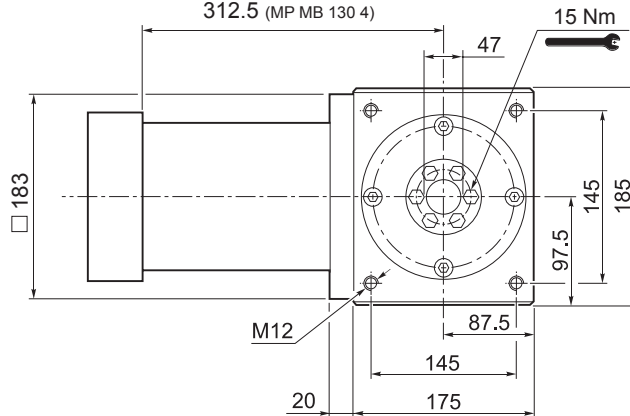

233.5 (MP MB 130 2)
273 (MP MB 130 3)
312.5 (MP MB 130 4)



	
MP MB 130 2	54
MP MB 130 3	58
MP MB 130 4	61

MP

												N	N1	N2	N3	N4	N5	L _{max}
55A1	14	15.875	16	19	-	-	-	-	-	-	-	55.5	125.7	130	4	M6x15	39.5	50
80A2	14	15.875	16	19	-	-	-	-	-	-	-	80	100	130	4	M6x15	39.5	50
95A1	14	15.875	16	19	22	24	-	-	-	-	-	95	115	130	4	M8x20	39.5	50
110A1	14	15.875	16	19	22	24	-	-	-	-	-	110	130	130	4	M8x20	39.5	50
110B1	14	15.875	16	19	22	24	-	-	-	-	-	110	145	130	6.5	M8x20	49.5	60
114A0	14	15.875	16	19	22	24	-	-	-	-	-	114.3	200	170	5.5	M12x25	39.5	50
114A	14	15.875	16	19	22	24	28	32	35	38	-	114.3	200	170	5.5	M12x25	69.5	80
130A	14	15.875	16	19	22	24	-	-	-	-	-	130	165	140	4	M10x20	39.5	50
130A1	14	15.875	16	19	22	24	28	32	-	-	-	130	165	140	4	M10x20	49.5	60
180A	14	15.875	16	19	22	24	28	32	-	-	-	180	215	190	5.5	M14x25	49.5	60
180A1	14	15.875	16	19	22	24	28	32	35	38	-	180	215	190	5.5	M14x25	69.5	80

Für weitere Motoradapter und Antriebswellenbohrungen bitte nachfragen.

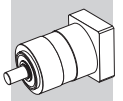

MP MB 130

FM

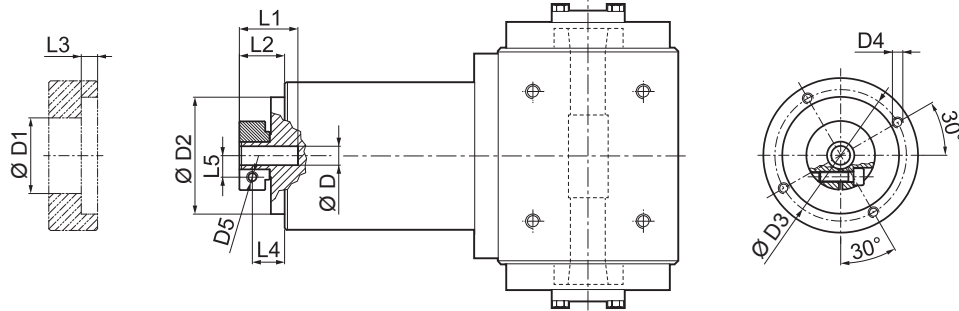

	D1	D2	D3	D4	D5	L1	L2	L3	L4	L5
14	48	113	125.5	M8x15	M6	40	27.5	6	20	14.5
19	51	113	125.5	M8x15	M6	40	27.5	6	20	16.5
22	56.5	113	125.5	M8x15	M6	41	28.5	6	19.5	19
28	67	113	125.5	M8x15	M8	41	28.5	6	19.5	22.5
32	71	113	125.5	M8x15	M8	41	28.5	6	19.5	24.5
35	73	113	125.5	M8x15	M8	50	37.5	11.25	26	26
38	77.5	113	125.5	M8x15	M8	50	37.5	11.25	26	28

	i	M _{n2} [Nm]	M _{a2} [Nm]	M _{p2} [Nm]	n ₁ [min ⁻¹]	n _{1 max} [min ⁻¹]	φ _S [arcmin]	φ _R [arcmin]	C _t [Nm/arcmin]	η %	J _G [kgcm ²]			
												14 ... 19	22 - 24	28 - 32
MP MB 130 2_3		215	400	800	2100	3000	15'	10'	43.0	94	5.25	5.46	5.81	7.16
MP MB 130 2_4		380	600	1100	2400	3500	15'	10'	43.0	94	3.06	3.26	3.61	4.97
MP MB 130 2_5		380	600	1100	2900	3500	15'	10'	43.0	94	2.22	2.42	2.77	4.13
MP MB 130 2_6		380	600	1100	2900	3500	15'	10'	43.0	94	1.19	1.40	1.75	3.10
MP MB 130 2_7		380	600	1100	3200	4000	15'	10'	43.0	94	1.47	1.68	2.03	3.38
MP MB 130 2_10		215	400	800	3200	4000	15'	10'	43.0	94	1.04	1.25	1.60	2.95
MP MB 130 3_9		215	400	800	2100	3000	15'	10'	37.5	91	4.82	5.02	5.37	6.72
MP MB 130 3_12		450	700	1300	2100	3000	15'	10'	37.5	91	4.57	4.78	5.13	6.48
MP MB 130 3_15		450	700	1300	2100	3000	15'	10'	37.5	91	4.48	4.69	5.04	6.39
MP MB 130 3_16		450	700	1300	2400	3500	15'	10'	37.5	91	2.67	2.88	3.23	4.58
MP MB 130 3_20		450	700	1300	2900	3500	15'	10'	37.5	91	1.97	2.18	2.53	3.88
MP MB 130 3_25		450	700	1300	2900	3500	15'	10'	37.5	91	1.94	2.15	2.50	3.85
MP MB 130 3_28		450	700	1300	3200	4000	15'	10'	37.5	91	1.34	1.55	1.90	3.25
MP MB 130 3_30		215	400	800	3200	4000	15'	10'	37.5	91	1.00	1.21	1.56	2.91
MP MB 130 3_35		450	700	1300	3200	4000	15'	10'	37.5	91	1.33	1.53	1.88	3.24
MP MB 130 3_36		380	600	1100	2900	3500	15'	10'	37.5	91	1.05	1.26	1.61	2.96
MP MB 130 3_40		450	700	1300	3200	4000	15'	10'	37.5	91	0.98	1.19	1.54	2.89
MP MB 130 3_50		450	700	1300	3200	4000	15'	10'	37.5	91	0.97	1.18	1.53	2.88
MP MB 130 3_70		450	700	1300	3200	4000	15'	10'	37.5	91	0.96	1.17	1.52	2.87
MP MB 130 3_100		215	400	800	3200	4000	15'	10'	37.5	91	0.96	1.17	1.52	2.87
MP MB 130 4_48		450	700	1300	2400	3500	17'	12'	29.5	89	2.77	2.98	3.33	4.68
MP MB 130 4_64		450	700	1300	2400	3500	17'	12'	29.5	89	2.65	2.86	3.21	4.56
MP MB 130 4_75		450	700	1300	2900	3500	17'	12'	29.5	89	2.03	2.24	2.59	3.94
MP MB 130 4_80		450	700	1300	2400	3500	17'	12'	29.5	89	2.65	2.85	3.20	4.56
MP MB 130 4_84		450	700	1300	3200	4000	17'	12'	29.5	89	1.37	1.58	1.93	3.28
MP MB 130 4_90		215	400	800	3200	4000	17'	12'	29.5	89	1.00	1.20	1.55	2.91
MP MB 130 4_120		450	700	1300	3200	4000	17'	12'	29.5	89	0.99	1.20	1.55	2.90
MP MB 130 4_125		450	700	1300	2900	3500	17'	12'	29.5	89	1.93	2.13	2.48	3.84
MP MB 130 4_140		450	700	1300	3200	4000	17'	12'	29.5	89	1.34	1.54	1.89	3.25
MP MB 130 4_150		450	700	1300	3200	4000	17'	12'	29.5	89	0.99	1.20	1.55	2.90
MP MB 130 4_160		450	700	1300	3200	4000	17'	12'	29.5	89	0.98	1.18	1.53	2.89
MP MB 130 4_175		450	700	1300	3200	4000	17'	12'	29.5	89	1.32	1.53	1.88	3.23
MP MB 130 4_200		450	700	1300	3200	4000	17'	12'	29.5	89	0.97	1.18	1.53	2.88
MP MB 130 4_210		450	700	1300	3200	4000	17'	12'	29.5	89	0.99	1.20	1.55	2.90
MP MB 130 4_216		450	700	1300	2900	3500	17'	12'	29.5	89	1.05	1.26	1.61	2.96
MP MB 130 4_250		450	700	1300	3200	4000	17'	12'	29.5	89	0.97	1.18	1.53	2.88
MP MB 130 4_280		450	700	1300	3200	4000	17'	12'	29.5	89	0.96	1.17	1.52	2.87
MP MB 130 4_350		450	700	1300	3200	4000	17'	12'	29.5	89	0.96	1.17	1.52	2.87
MP MB 130 4_400		450	700	1300	3200	4000	17'	12'	29.5	89	0.96	1.17	1.52	2.87
MP MB 130 4_500		450	700	1300	3200	4000	17'	12'	29.5	89	0.96	1.17	1.52	2.87
MP MB 130 4_700		450	700	1300	3200	4000	17'	12'	29.5	89	0.96	1.17	1.52	2.87
MP MB 130 4_1000		215	400	800	3200	4000	17'	12'	29.5	89	0.96	1.17	1.52	2.87

MP



MP 160

IS

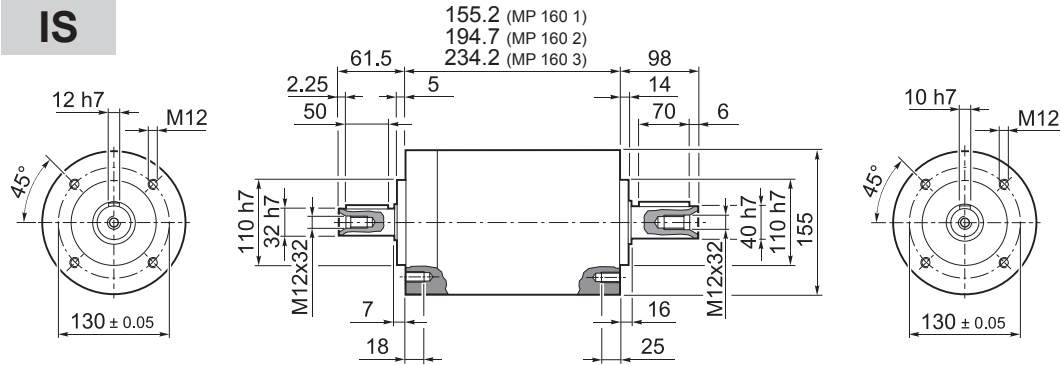

MP 160 1	17.0
MP 160 2	21
MP 160 3	28

55A1 ... 180A1

MP

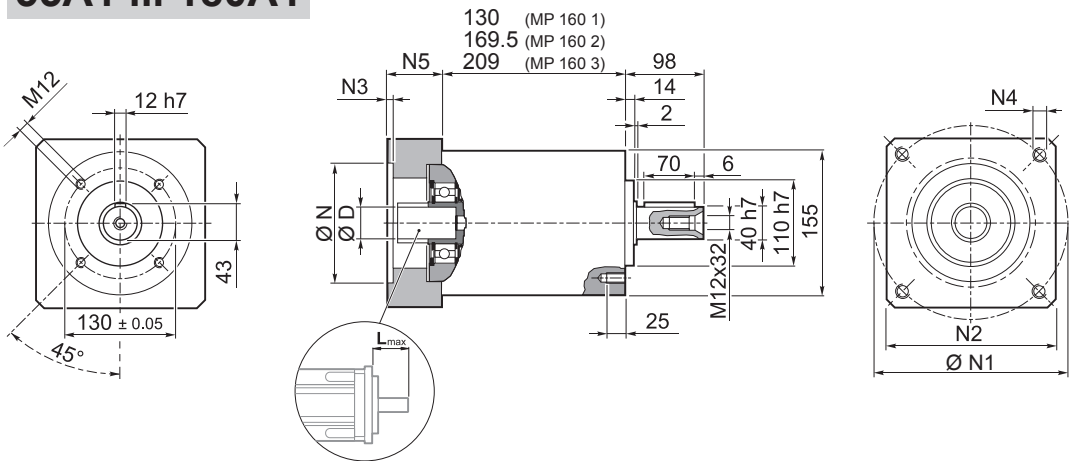

MP 160 1	17.0
MP 160 2	21
MP 160 3	28

											N	N1	N2	N3	N4	N5	L _{max}
55A1	14	15.875	16	19	-	-	-	-	-	-	55.5	125.7	140	5	M6x15	39.5	50
80A2	14	15.875	16	19	-	-	-	-	-	-	80	100	140	5	M6x15	39.5	50
95A1	14	15.875	16	19	22	24	-	-	-	-	95	115	140	5	M8x20	39.5	50
110A1	14	15.875	16	19	22	24	-	-	-	-	110	130	140	5	M8x20	39.5	50
110B1	14	15.875	16	19	22	24	-	-	-	-	110	145	140	6.5	M8x20	49.5	60
114A	14	15.875	16	19	22	24	28	32	35	38	114.3	200	170	6.5	M12x25	69.5	80
130A	14	15.875	16	19	22	24	-	-	-	-	130	165	140	5	M10x20	39.5	50
130A1	14	15.875	16	19	22	24	28	32	-	-	130	165	140	5	M10x20	49.5	60
180A	14	15.875	16	19	22	24	28	32	-	-	180	215	190	6.5	M14x25	49.5	60
180A1	14	15.875	16	19	22	24	28	32	35	38	180	215	190	6.5	M14x25	69.5	80

Für weitere Motoradapter und Antriebswellenbohrungen bitte nachfragen.

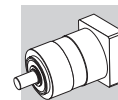

MP 160

FM

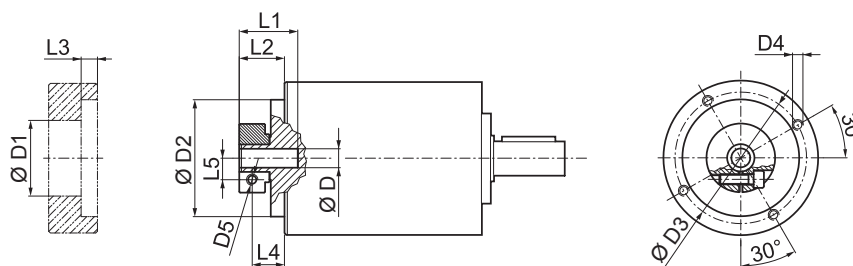

D	D1	D2	D3	D4	D5	L1	L2	L3	L4	L5
14	48	130	142.5	M8x16	M6	40	27.5	6	20	14.5
19	51	130	142.5	M8x16	M6	40	27.5	6	20	16.5
22	56.5	130	142.5	M8x16	M6	41	28.5	6	19.5	19
28	67	130	142.5	M8x16	M8	41	28.5	6	19.5	22.5
32	71	130	142.5	M8x16	M8	41	28.5	6	19.5	24.5
35	73	130	142.5	M8x16	M8	50	37.5	11.25	26	26
38	77.5	130	142.5	M8x16	M8	50	37.5	11.25	26	28

i	M _{n 2} [Nm]	M _{a 2} [Nm]	M _{p 2} [Nm]	n ₁ [min ⁻¹]	n _{1 max} [min ⁻¹]	φ _S [arcmin]	φ _R [arcmin]	C _t [Nm/arcmin]	R _{1 max} [N]	R _{2 max} [N]	A _{2 max} [N]	η [%]	J _G [kgcm ²]			
													14 ... 19	22 - 24	28 - 32	35 - 38
MP 160 1_3	350	660	1200	1900	3000	15'	10'	90	1200	6500	7500	97	8.39	8.60	8.95	10.30
MP 160 1_4	500	750	1400	2200	3500	15'	10'	90	1200	6500	7500	97	4.68	4.89	5.24	6.59
MP 160 1_5	500	750	1400	2500	3500	15'	10'	90	1200	6500	7500	97	3.28	3.49	3.84	5.19
MP 160 1_6	500	750	1400	2500	3500	15'	10'	90	1200	6500	7500	97	1.32	1.53	1.88	3.23
MP 160 1_7	500	750	1400	3000	4000	15'	10'	90	1200	6500	7500	97	2.03	2.24	2.59	3.94
MP 160 1_10	350	660	1200	3000	4000	15'	10'	90	1200	6500	7500	97	1.33	1.53	1.88	3.24
MP 160 2_9	350	660	1200	1900	3000	15'	10'	83	1200	6500	7500	94	7.51	7.72	8.07	9.42
MP 160 2_12	700	950	1800	1900	3000	15'	10'	83	1200	6500	7500	94	7.10	7.30	7.65	9.01
MP 160 2_15	700	950	1800	1900	3000	15'	10'	83	1200	6500	7500	94	6.94	7.15	7.50	8.85
MP 160 2_16	700	950	1800	2200	3500	15'	10'	83	1200	6500	7500	94	3.95	4.16	4.51	5.86
MP 160 2_20	700	950	1800	2500	3500	15'	10'	83	1200	6500	7500	94	2.82	3.02	3.37	4.73
MP 160 2_25	700	950	1800	2500	3500	15'	10'	83	1200	6500	7500	94	2.76	2.97	3.32	4.67
MP 160 2_28	700	950	1800	3000	4000	15'	10'	83	1200	6500	7500	94	1.79	2.00	2.35	3.70
MP 160 2_30	350	660	1200	3000	4000	15'	10'	83	1200	6500	7500	94	1.25	1.46	1.81	3.16
MP 160 2_35	700	950	1800	3000	4000	15'	10'	83	1200	6500	7500	94	1.77	1.97	2.32	3.68
MP 160 2_36	500	750	1400	2500	3500	15'	10'	83	1200	6500	7500	94	1.06	1.27	1.62	2.97
MP 160 2_40	700	950	1800	3000	4000	15'	10'	83	1200	6500	7500	94	1.21	1.42	1.77	3.12
MP 160 2_50	700	950	1800	3000	4000	15'	10'	83	1200	6500	7500	94	1.20	1.40	1.75	3.11
MP 160 2_70	700	950	1800	3000	4000	15'	10'	83	1200	6500	7500	94	1.18	1.39	1.74	3.09
MP 160 2_100	350	660	1200	3000	4000	15'	10'	83	1200	6500	7500	94	1.18	1.38	1.73	3.09
MP 160 3_48	700	950	1800	2200	3500	17'	12'	60	1200	6500	7500	91	4.10	4.31	4.66	6.01
MP 160 3_64	700	950	1800	2200	3500	17'	12'	60	1200	6500	7500	91	3.90	4.11	4.46	5.81
MP 160 3_75	700	950	1800	2500	3500	17'	12'	60	1200	6500	7500	91	2.91	3.11	3.46	4.82
MP 160 3_80	700	950	1800	2200	3500	17'	12'	60	1200	6500	7500	91	3.90	4.11	4.46	5.81
MP 160 3_84	700	950	1800	3000	4000	17'	12'	60	1200	6500	7500	91	1.84	2.05	2.40	3.75
MP 160 3_90	350	660	1200	3000	4000	17'	12'	60	1200	6500	7500	91	1.24	1.45	1.80	3.15
MP 160 3_120	700	950	1800	3000	4000	17'	12'	60	1200	6500	7500	91	1.23	1.44	1.79	3.14
MP 160 3_125	700	950	1800	2500	3500	17'	12'	60	1200	6500	7500	91	2.74	2.95	3.30	4.65
MP 160 3_140	700	950	1800	3000	4000	17'	12'	60	1200	6500	7500	91	1.78	1.98	2.33	3.69
MP 160 3_150	700	950	1800	3000	4000	17'	12'	60	1200	6500	7500	91	1.23	1.44	1.79	3.14
MP 160 3_160	700	950	1800	3000	4000	17'	12'	60	1200	6500	7500	91	1.20	1.41	1.76	3.11
MP 160 3_175	700	950	1800	3000	4000	17'	12'	60	1200	6500	7500	91	1.76	1.96	2.31	3.67
MP 160 3_200	700	950	1800	3000	4000	17'	12'	60	1200	6500	7500	91	1.20	1.41	1.76	3.11
MP 160 3_210	700	950	1800	3000	4000	17'	12'	60	1200	6500	7500	91	1.23	1.44	1.79	3.14
MP 160 3_250	700	950	1800	3000	4000	17'	12'	60	1200	6500	7500	91	1.19	1.40	1.75	3.10
MP 160 3_280	700	950	1800	3000	4000	17'	12'	60	1200	6500	7500	91	1.18	1.39	1.74	3.09
MP 160 3_350	700	950	1800	3000	4000	17'	12'	60	1200	6500	7500	91	1.18	1.39	1.74	3.09
MP 160 3_400	700	950	1800	3000	4000	17'	12'	60	1200	6500	7500	91	1.18	1.38	1.73	3.09
MP 160 3_500	700	950	1800	3000	4000	17'	12'	60	1200	6500	7500	91	1.18	1.38	1.73	3.09
MP 160 3_700	700	950	1800	3000	4000	17'	12'	60	1200	6500	7500	91	1.18	1.38	1.73	3.09
MP 160 3_1000	350	660	1200	3000	4000	17'	12'	60	1200	6500	7500	91	1.18	1.38	1.73	3.09

MP



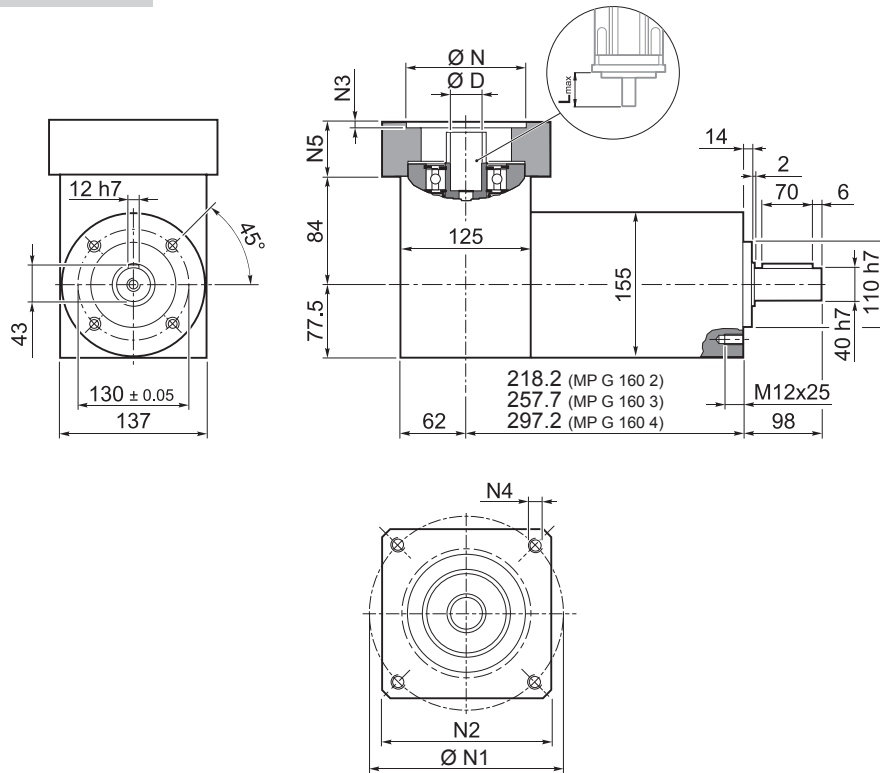

MP G 160

55A1 ... 180A1



	
MP G 160 2	24
MP G 160 3	28
MP G 160 4	34

MP

											N	N1	N2	N3	N4	N5	L _{max}
55A1	14	15.875	16	19	-	-	-	-	-	-	55.5	125.7	140	5	M6x15	39.5	50
80A2	14	15.875	16	19	-	-	-	-	-	-	80	100	140	5	M6x15	39.5	50
95A1	14	15.875	16	19	22	24	-	-	-	-	95	115	140	5	M8x20	39.5	50
110A1	14	15.875	16	19	22	24	-	-	-	-	110	130	140	5	M8x20	39.5	50
110B1	14	15.875	16	19	22	24	-	-	-	-	110	145	140	6.5	M8x20	49.5	60
114A	14	15.875	16	19	22	24	28	32	35	38	114.3	200	170	6.5	M12x25	69.5	80
130A	14	15.875	16	19	22	24	-	-	-	-	130	165	140	5	M10x20	39.5	50
130A1	14	15.875	16	19	22	24	28	32	-	-	130	165	140	5	M10x20	49.5	60
180A	14	15.875	16	19	22	24	28	32	-	-	180	215	190	6.5	M14x25	49.5	60
180A1	14	15.875	16	19	22	24	28	32	35	38	180	215	190	6.5	M14x25	69.5	80

Für weitere Motoradapter und Antriebswellenbohrungen bitte nachfragen.

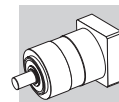

MP G 160

FM

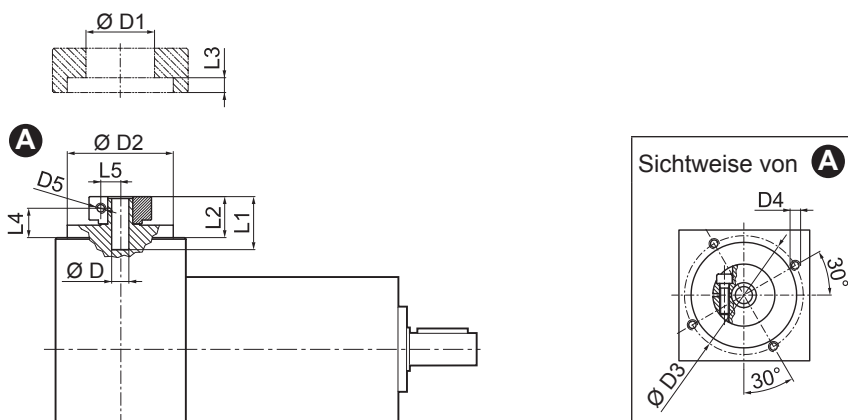

D			D1	D2	D3	D4	D5	L1	L2	L3	L4	L5
14	15.875	16	48	113	125.5	M8x15	M6	40	27.5	6	20	14.5
19			51	113	125.5	M8x15	M6	40	27.5	6	20	16.5
22	24		56.5	113	125.5	M8x15	M6	41	28.5	6	19.5	19
28			67	113	125.5	M8x15	M8	41	28.5	6	19.5	22.5
32			71	113	125.5	M8x15	M8	41	28.5	6	19.5	24.5
35			73	113	125.5	M8x15	M8	50	37.5	11.25	26	26
38			77.5	113	125.5	M8x15	M8	50	37.5	11.25	26	28

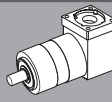
 i	M _{n2}	M _{a2}	M _{p2}	n ₁	n _{1max}	φ _S	φ _R	C _t	R _{2max}	A _{2max}	η	J _G [kgcm ²]			
	[Nm]	[Nm]	[Nm]	[min ⁻¹]	[min ⁻¹]	[arcmin]		$\frac{Nm}{arcmin}$	[N]	[N]	%	D			
													14 ... 19	22 - 24	28 - 32
MP G 160 2_3	350	660	1200	1900	3000	15'	10'	90	6500	7500	94	10.23	10.42	10.80	13.51
MP G 160 2_4	500	750	1400	2200	3500	15'	10'	90	6500	7500	94	6.52	6.71	7.09	9.80
MP G 160 2_5	500	750	1400	2500	3500	15'	10'	90	6500	7500	94	5.87	6.06	6.45	9.16
MP G 160 2_6	500	750	1400	2500	3500	15'	10'	90	6500	7500	94	4.58	4.77	5.16	7.86
MP G 160 2_7	500	750	1400	3000	4000	15'	10'	90	6500	7500	94	5.29	5.48	5.87	8.57
MP G 160 2_10	350	660	1200	3000	4000	15'	10'	90	6500	7500	94	4.97	5.16	5.54	8.25
MP G 160 3_9	350	660	1200	1900	3000	15'	10'	83	6500	7500	91	9.35	9.54	9.92	12.63
MP G 160 3_12	700	950	1800	1900	3000	15'	10'	83	6500	7500	91	8.78	8.97	9.36	12.07
MP G 160 3_15	700	950	1800	1900	3000	15'	10'	83	6500	7500	91	8.71	8.90	9.29	11.99
MP G 160 3_16	700	950	1800	2200	3500	15'	10'	83	6500	7500	91	5.79	5.98	6.36	9.07
MP G 160 3_20	700	950	1800	2500	3500	15'	10'	83	6500	7500	91	5.41	6.20	6.59	9.30
MP G 160 3_25	700	950	1800	2500	3500	15'	10'	83	6500	7500	91	5.95	5.54	5.93	8.64
MP G 160 3_28	700	950	1800	3000	4000	15'	10'	83	6500	7500	91	5.05	5.24	5.63	8.33
MP G 160 3_30	350	660	1200	3000	4000	15'	10'	83	6500	7500	91	4.89	5.09	5.47	8.18
MP G 160 3_35	700	950	1800	3000	4000	15'	10'	83	6500	7500	91	5.36	5.54	5.93	8.64
MP G 160 3_36	500	750	1400	2500	3500	15'	10'	83	6500	7500	91	4.32	4.51	4.90	7.60
MP G 160 3_40	700	950	1800	3000	4000	15'	10'	83	6500	7500	91	5.00	5.19	5.58	8.28
MP G 160 3_50	700	950	1800	3000	4000	15'	10'	83	6500	7500	91	4.99	5.18	5.56	8.27
MP G 160 3_70	700	950	1800	3000	4000	15'	10'	83	6500	7500	91	4.82	5.02	5.40	8.11
MP G 160 3_100	350	660	1200	3000	4000	15'	10'	83	6500	7500	91	4.82	5.01	5.39	8.10
MP G 160 4_48	700	950	1800	2200	3500	17'	12'	60	6500	7500	89	5.94	6.13	6.53	9.22
MP G 160 4_64	700	950	1800	2200	3500	17'	12'	60	6500	7500	89	5.74	5.93	6.31	9.02
MP G 160 4_75	700	950	1800	2500	3500	17'	12'	60	6500	7500	89	5.50	5.68	6.07	8.79
MP G 160 4_80	700	950	1800	2200	3500	17'	12'	60	6500	7500	89	5.74	5.93	6.31	9.02
MP G 160 4_84	700	950	1800	3000	4000	17'	12'	60	6500	7500	89	5.10	5.29	5.68	8.38
MP G 160 4_90	350	660	1200	3000	4000	17'	12'	60	6500	7500	89	4.88	5.08	5.46	8.17
MP G 160 4_120	700	950	1800	3000	4000	17'	12'	60	6500	7500	89	4.87	5.07	5.45	8.16
MP G 160 4_125	700	950	1800	2500	3500	17'	12'	60	6500	7500	89	5.33	5.52	5.91	8.62
MP G 160 4_140	700	950	1800	3000	4000	17'	12'	60	6500	7500	89	5.04	5.22	5.61	8.32
MP G 160 4_150	700	950	1800	3000	4000	17'	12'	60	6500	7500	89	4.87	5.07	5.45	8.16
MP G 160 4_160	700	950	1800	3000	4000	17'	12'	60	6500	7500	89	4.84	5.04	5.42	8.13
MP G 160 4_175	700	950	1800	3000	4000	17'	12'	60	6500	7500	89	5.02	5.20	5.59	8.30
MP G 160 4_200	700	950	1800	3000	4000	17'	12'	60	6500	7500	89	4.84	5.04	5.42	8.13
MP G 160 4_210	700	950	1800	3000	4000	17'	12'	60	6500	7500	89	4.87	5.07	5.45	8.16
MP G 160 4_250	700	950	1800	3000	4000	17'	12'	60	6500	7500	89	4.83	5.03	5.41	8.12
MP G 160 4_280	700	950	1800	3000	4000	17'	12'	60	6500	7500	89	4.82	5.02	5.40	8.11
MP G 160 4_350	700	950	1800	3000	4000	17'	12'	60	6500	7500	89	4.82	2.05	5.40	8.11
MP G 160 4_400	700	950	1800	3000	4000	17'	12'	60	6500	7500	89	4.82	5.01	5.39	8.11
MP G 160 4_500	700	950	1800	3000	4000	17'	12'	60	6500	7500	89	4.82	5.01	5.39	8.11
MP G 160 4_700	700	950	1800	3000	4000	17'	12'	60	6500	7500	89	4.82	5.01	5.39	8.11
MP G 160 4_1000	350	660	1200	3000	4000	17'	12'	60	6500	7500	89	4.82	5.01	5.39	8.11

MP



MP MB 160

55A1 ... 180A1

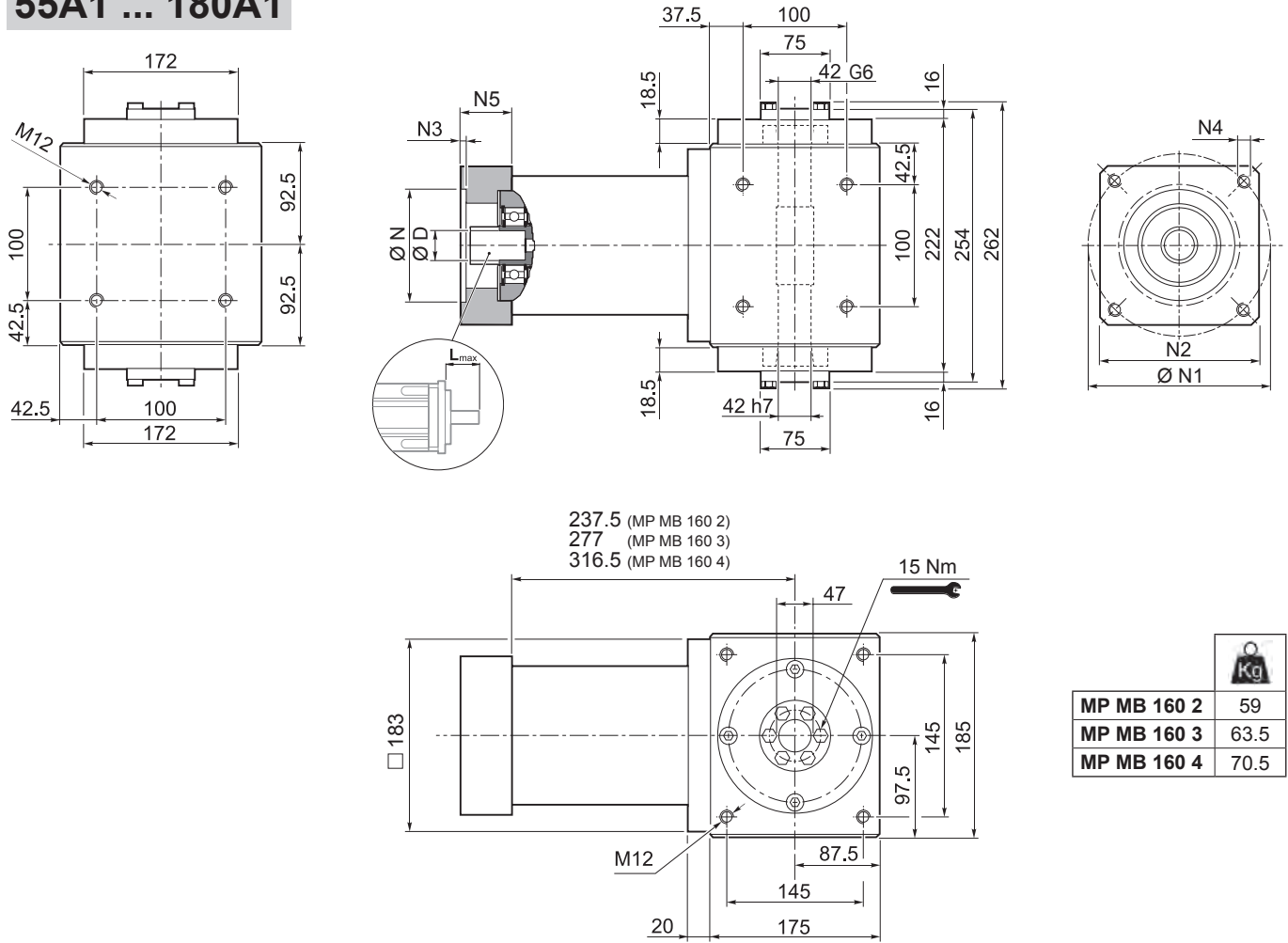

MP

Model	Dimensions (mm)										N	N1	N2	N3	N4	N5	L _{max}
	14	15.875	16	19	-	-	-	-	-	-							
55A1	14	15.875	16	19	-	-	-	-	-	-	55.5	125.7	140	5	M6x15	39.5	50
80A2	14	15.875	16	19	-	-	-	-	-	-	80	100	140	5	M6x15	39.5	50
95A1	14	15.875	16	19	22	24	-	-	-	-	95	115	140	5	M8x20	39.5	50
110A1	14	15.875	16	19	22	24	-	-	-	-	110	130	140	5	M8x20	39.5	50
110B1	14	15.875	16	19	22	24	-	-	-	-	110	145	140	6.5	M8x20	49.5	60
114A	14	15.875	16	19	22	24	28	32	35	38	114.3	200	170	6.5	M12x25	69.5	80
130A	14	15.875	16	19	22	24	-	-	-	-	130	165	140	5	M10x20	39.5	50
130A1	14	15.875	16	19	22	24	28	32	-	-	130	165	140	5	M10x20	49.5	60
180A	14	15.875	16	19	22	24	28	32	-	-	180	215	190	6.5	M14x25	49.5	60
180A1	14	15.875	16	19	22	24	28	32	35	38	180	215	190	6.5	M14x25	69.5	80

Für weitere Motoradapter und Antriebswellenbohrungen bitte nachfragen.

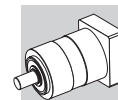

MP MB 160

FM

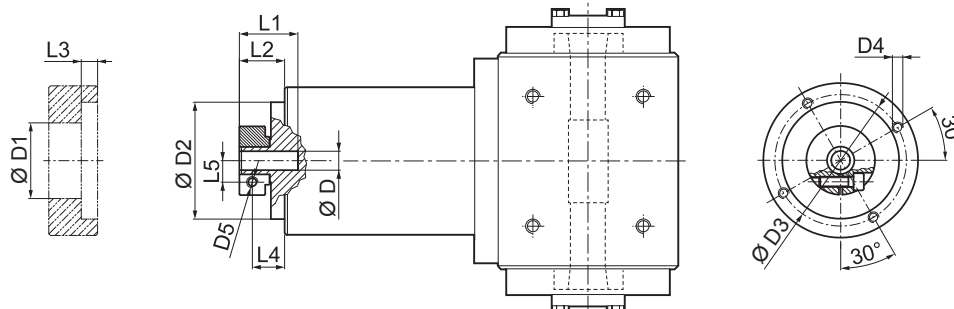

	D1	D2	D3	D4	D5	L1	L2	L3	L4	L5
14 15.875 16	48	130	142.5	M8x16	M6	40	27.5	6	20	14.5
19	51	130	142.5	M8x16	M6	40	27.5	6	20	16.5
22 24	56.5	130	142.5	M8x16	M6	41	28.5	6	19.5	19
28	67	130	142.5	M8x16	M8	41	28.5	6	19.5	22.5
32	71	130	142.5	M8x16	M8	41	28.5	6	19.5	24.5
35	73	130	142.5	M8x16	M8	50	37.5	11.25	26	26
38	77.5	130	142.5	M8x16	M8	50	37.5	11.25	26	28

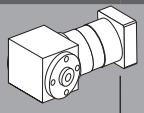
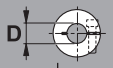
	M_{n2} [Nm]	M_{a2} [Nm]	M_{p2} [Nm]	n_1 [min ⁻¹]	n_{1max} [min ⁻¹]	φ_S [arcmin]	φ_R [arcmin]	C_t [Nm/arcmin]	η %	J_G [kgcm ²]			
											14 ... 19	22 - 24	28 - 32
MP MB 160 2_3	350	660	1200	1900	3000	15'	10'	90	94	8.39	8.60	8.95	10.30
MP MB 160 2_4	500	750	1400	2200	3500	15'	10'	90	94	4.68	4.89	5.24	6.59
MP MB 160 2_5	500	750	1400	2500	3500	15'	10'	90	94	3.28	3.49	3.84	5.19
MP MB 160 2_6	500	750	1400	2500	3500	15'	10'	90	94	1.32	1.53	1.88	3.23
MP MB 160 2_7	500	750	1400	3000	4000	15'	10'	90	94	2.03	2.24	2.59	3.94
MP MB 160 2_10	350	660	1200	3000	4000	15'	10'	90	94	1.33	1.53	1.88	3.24
MP MB 160 3_9	350	660	1200	1900	3000	15'	10'	83	91	7.51	7.72	8.07	9.42
MP MB 160 3_12	700	950	1800	1900	3000	15'	10'	83	91	7.10	7.30	7.65	9.01
MP MB 160 3_15	700	950	1800	1900	3000	15'	10'	83	91	6.94	7.15	7.50	8.85
MP MB 160 3_16	700	950	1800	2200	3500	15'	10'	83	91	3.95	4.16	4.51	5.86
MP MB 160 3_20	700	950	1800	2500	3500	15'	10'	83	91	2.82	3.02	3.37	4.73
MP MB 160 3_25	700	950	1800	2500	3500	15'	10'	83	91	2.76	2.97	3.32	4.67
MP MB 160 3_28	700	950	1800	3000	4000	15'	10'	83	91	1.79	2.00	2.35	3.70
MP MB 160 3_30	350	660	1200	3000	4000	15'	10'	83	91	1.25	1.46	1.81	3.16
MP MB 160 3_35	700	950	1800	3000	4000	15'	10'	83	91	1.77	1.97	2.32	3.68
MP MB 160 3_36	500	750	1400	2500	3500	15'	10'	83	91	1.06	1.27	1.62	2.97
MP MB 160 3_40	700	950	1800	3000	4000	15'	10'	83	91	1.21	1.42	1.77	3.12
MP MB 160 3_50	700	950	1800	3000	4000	15'	10'	83	91	1.20	1.40	1.75	3.11
MP MB 160 3_70	700	950	1800	3000	4000	15'	10'	83	91	1.18	1.39	1.74	3.09
MP MB 160 3_100	350	660	1200	3000	4000	15'	10'	83	91	1.18	1.38	1.73	3.09
MP MB 160 4_48	700	950	1800	2200	3500	17'	12'	60	89	4.10	4.31	4.66	6.01
MP MB 160 4_64	700	950	1800	2200	3500	17'	12'	60	89	3.90	4.11	4.46	5.81
MP MB 160 4_75	700	950	1800	2500	3500	17'	12'	60	89	2.91	3.11	3.46	4.82
MP MB 160 4_80	700	950	1800	2200	3500	17'	12'	60	89	3.90	4.11	4.46	5.81
MP MB 160 4_84	700	950	1800	3000	4000	17'	12'	60	89	1.84	2.05	2.40	3.75
MP MB 160 4_90	350	660	1200	3000	4000	17'	12'	60	89	1.24	1.45	1.80	3.15
MP MB 160 4_120	700	950	1800	3000	4000	17'	12'	60	89	1.23	1.44	1.79	3.14
MP MB 160 4_125	700	950	1800	2500	3500	17'	12'	60	89	2.74	2.95	3.30	4.65
MP MB 160 4_140	700	950	1800	3000	4000	17'	12'	60	89	1.78	1.98	2.33	3.69
MP MB 160 4_150	700	950	1800	3000	4000	17'	12'	60	89	1.23	1.44	1.79	3.14
MP MB 160 4_160	700	950	1800	3000	4000	17'	12'	60	89	1.20	1.41	1.76	3.11
MP MB 160 4_175	700	950	1800	3000	4000	17'	12'	60	89	1.76	1.96	2.31	3.67
MP MB 160 4_200	700	950	1800	3000	4000	17'	12'	60	89	1.20	1.41	1.76	3.11
MP MB 160 4_210	700	950	1800	3000	4000	17'	12'	60	89	1.23	1.44	1.79	3.14
MP MB 160 4_250	700	950	1800	3000	4000	17'	12'	60	89	1.19	1.40	1.75	3.10
MP MB 160 4_280	700	950	1800	3000	4000	17'	12'	60	89	1.18	1.39	1.74	3.09
MP MB 160 4_350	700	950	1800	3000	4000	17'	12'	60	89	1.18	1.39	1.74	3.09
MP MB 160 4_400	700	950	1800	3000	4000	17'	12'	60	89	1.18	1.38	1.73	3.09
MP MB 160 4_500	700	950	1800	3000	4000	17'	12'	60	89	1.18	1.38	1.73	3.09
MP MB 160 4_700	700	950	1800	3000	4000	17'	12'	60	89	1.18	1.38	1.73	3.09
MP MB 160 4_1000	350	660	1200	3000	4000	17'	12'	60	89	1.18	1.38	1.73	3.09

MP



MP 190

55A1 ... 180A1

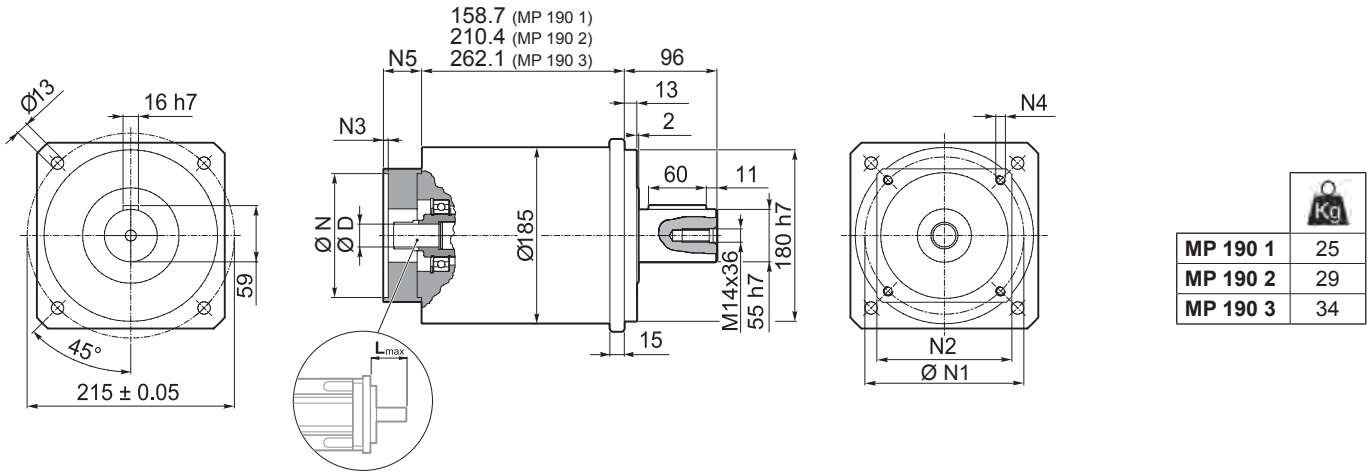

MP	D	D												N	N1	N2	N3	N4	N5	L _{max}
		14	16	19	-	-	-	-	-	-	-	-	-							
55A1	14 16 19	-	-	-	-	-	-	-	-	-	-	-	55.5	125.7	140	5	M6x15	39.5	50	
80A2	14 16 19	-	-	-	-	-	-	-	-	-	-	-	80	100	140	5	M6x15	39.5	50	
95A1	14 16 19	22	24	-	-	-	-	-	-	-	-	-	95	115	140	5	M8x20	39.5	50	
110A1	14 16 19	22	24	-	-	-	-	-	-	-	-	-	110	130	140	5	M8x20	39.5	50	
110B1	14 16 19	22	24	-	-	-	-	-	-	-	-	-	110	145	140	6.5	M8x20	49.5	60	
114A	14 16 19	22	24	28	32	35	38	42	45	48	-	-	114.3	200	170	6.5	M12x25	69.5	80	
130A	14 16 19	22	24	-	-	-	-	-	-	-	-	-	130	165	140	5	M10x20	39.5	50	
130A1	14 16 19	22	24	28	32	-	-	-	-	-	-	-	130	165	140	5	M10x20	49.5	60	
180A	14 16 19	22	24	28	32	-	-	-	-	-	-	-	180	215	190	6.5	M14x25	49.5	60	
180A1	14 16 19	22	24	28	32	35	38	42	45	48	-	-	180	215	190	6.5	M14x25	69.5	80	

Für weitere Motoradapter und Antriebswellenbohrungen bitte nachfragen.

FM

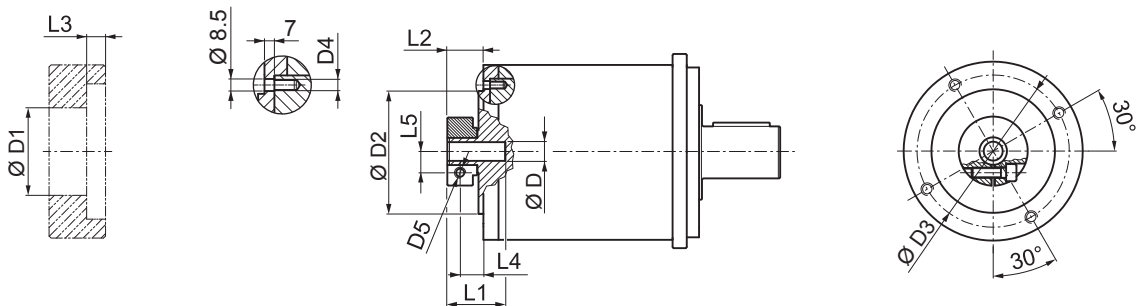

D	D1	D2	D3	D4	D5	L1	L2	L3	L4	L5
14 16	48	130	142.5	M8x14	M6	45.5	27.5	6	20	14.5
19	51	130	142.5	M8x14	M6	45.5	27.5	6	20	16.5
22 24	56.5	130	142.5	M8x14	M6	47	29	6	20	19
28	67	130	142.5	M8x14	M8	47	29	6	20	22.5
32	71	130	142.5	M8x14	M8	47	29	6	20	24.5
35	73	130	142.5	M8x14	M8	54.5	36.5	6	25	26
38	77.5	130	142.5	M8x14	M8	54.5	36.5	6	25	28
42	92	130	142.5	M8x14	M10	60.5	40	6	25	33
45	95	130	142.5	M8x14	M10	60.5	40	6	25	33
48	97	130	142.5	M8x14	M10	60.5	40	6	25	33

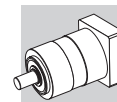

MP 190

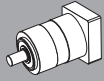
 i	M _{n 2} [Nm]	M _{a 2} [Nm]	M _{p 2} [Nm]	n ₁ [min ⁻¹]	n _{1 max} [min ⁻¹]	φ _S [arcmin]	φ _R [arcmin]	C _t [$\frac{Nm}{arcmin}$]	R _{2 max} [N]	A _{2 max} [N]	η %	J _G [kgcm ²]				
												14 ... 24	28 - 32	35 - 35	42	45 - 48
MP 190 1_3	500	800	1400	1500	2500	15'	10'	130	14000	15000	97	24.20	24.88	25.65	29.30	29.90
MP 190 1_4	700	950	1800	2100	3000	15'	10'	130	14000	15000	97	13.41	14.09	14.85	18.51	19.11
MP 190 1_5	700	950	1800	2300	3000	15'	10'	130	14000	15000	97	9.32	10.00	10.77	14.42	15.02
MP 190 1_6	700	950	1800	2300	3000	15'	10'	130	14000	15000	97	2.88	3.56	4.33	7.98	8.58
MP 190 1_7	700	950	1800	2900	3500	15'	10'	130	14000	15000	97	5.68	6.36	7.13	10.78	11.38
MP 190 1_10	500	800	1400	2900	3500	15'	10'	130	14000	15000	97	3.57	4.25	5.02	8.67	9.27
MP 190 2_9	500	800	1400	1500	2500	15'	10'	100	14000	15000	94	23.23	23.91	24.67	28.33	28.93
MP 190 2_12	1000	1200	2200	1500	2500	15'	10'	100	14000	15000	94	22.03	22.71	23.48	27.13	27.73
MP 190 2_15	1000	1200	2200	1500	2500	15'	10'	100	14000	15000	94	21.58	22.25	23.02	26.68	27.27
MP 190 2_16	1000	1200	2200	2100	3000	15'	10'	100	14000	15000	94	12.19	12.86	13.63	17.29	17.89
MP 190 2_20	1000	1200	2200	2300	3000	15'	10'	100	14000	15000	94	8.54	9.22	9.98	13.64	14.24
MP 190 2_25	1000	1200	2200	2300	3000	15'	10'	100	14000	15000	94	8.37	9.05	9.82	13.48	14.07
MP 190 2_28	1000	1200	2200	2900	3500	15'	10'	100	14000	15000	94	5.28	5.96	6.73	10.38	10.98
MP 190 2_30	500	800	1400	2900	3500	15'	10'	100	14000	15000	94	3.48	4.16	4.93	8.58	9.18
MP 190 2_35	1000	1200	2200	2900	3500	15'	10'	100	14000	15000	94	5.20	5.87	6.64	10.30	10.90
MP 190 2_36	700	950	1800	2300	3000	15'	10'	100	14000	15000	94	2.18	2.86	3.63	7.28	7.88
MP 190 2_40	1000	1200	2200	2900	3500	15'	10'	100	14000	15000	94	3.37	4.05	4.82	8.48	9.07
MP 190 2_50	1000	1200	2200	2900	3500	15'	10'	100	14000	15000	94	3.33	4.01	4.78	8.44	9.03
MP 190 2_70	1000	1200	2200	2900	3500	15'	10'	100	14000	15000	94	3.30	3.97	4.74	8.40	9.00
MP 190 2_100	500	800	1400	2900	3500	15'	10'	100	14000	15000	94	3.28	3.95	4.72	8.38	8.98
MP 190 3_48	1000	1200	2200	2100	3000	17'	12'	90	14000	15000	91	12.73	13.40	14.17	17.83	18.43
MP 190 3_64	1000	1200	2200	2100	3000	17'	12'	90	14000	15000	91	12.10	12.78	13.55	17.21	17.80
MP 190 3_75	1000	1200	2200	2300	3000	17'	12'	90	14000	15000	91	8.86	9.54	10.31	13.97	14.56
MP 190 3_80	1000	1200	2200	2100	3000	17'	12'	90	14000	15000	91	12.09	12.76	13.53	17.19	17.79
MP 190 3_84	1000	1200	2200	2900	3500	17'	12'	90	14000	15000	91	5.46	6.13	6.90	10.56	11.16
MP 190 3_90	500	800	1400	2900	3500	17'	12'	90	14000	15000	91	3.47	4.15	4.92	8.57	9.17
MP 190 3_120	1000	1200	2200	2900	3500	17'	12'	90	14000	15000	91	3.46	4.14	4.91	8.56	9.16
MP 190 3_125	1000	1200	2200	2300	3000	17'	12'	90	14000	15000	91	8.34	9.01	9.78	13.44	14.04
MP 190 3_140	1000	1200	2200	2900	3500	17'	12'	90	14000	15000	91	5.25	5.92	6.69	10.35	10.95
MP 190 3_150	1000	1200	2200	2900	3500	17'	12'	90	14000	15000	91	3.46	4.13	4.90	8.56	9.15
MP 190 3_160	1000	1200	2200	2900	3500	17'	12'	90	14000	15000	91	3.36	4.04	4.81	8.46	9.06
MP 190 3_175	1000	1200	2200	2900	3500	17'	12'	90	14000	15000	91	5.18	5.85	6.62	10.28	10.88
MP 190 3_200	1000	1200	2200	2900	3500	17'	12'	90	14000	15000	91	3.36	4.03	4.80	8.46	9.06
MP 190 3_210	1000	1200	2200	2900	3500	17'	12'	90	14000	15000	91	3.45	4.13	4.90	8.55	9.15
MP 190 3_250	1000	1200	2200	2900	3500	17'	12'	90	14000	15000	91	3.32	4.00	4.77	8.42	9.02
MP 190 3_280	1000	1200	2200	2900	3500	17'	12'	90	14000	15000	91	3.29	3.97	4.74	8.39	8.99
MP 190 3_350	1000	1200	2200	2900	3500	17'	12'	90	14000	15000	91	3.29	3.97	4.74	8.39	8.99
MP 190 3_400	1000	1200	2200	2900	3500	17'	12'	90	14000	15000	91	3.27	3.95	4.72	8.38	8.97
MP 190 3_500	1000	1200	2200	2900	3500	17'	12'	90	14000	15000	91	3.27	3.95	4.72	8.38	8.97
MP 190 3_700	1000	1200	2200	2900	3500	17'	12'	90	14000	15000	91	3.27	3.95	4.72	8.38	8.97
MP 190 3_1000	500	800	1400	2900	3500	17'	12'	90	14000	15000	91	3.27	3.95	4.72	8.38	8.97

MP

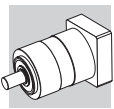

6.3.1 MASCHINENWELLE

Für die Welle der angetriebenen Maschine ist eine hochwertige Stahllegierung zu bevorzugen. Die Tabelle unten zeigt die empfohlenen Abmessungen, die vom Kunden bei der Konstruktion der Gegenwelle zu berücksichtigen sind. Weiterhin wird eine axiale Aufnahmevorrichtung für die Welle empfohlen (nicht gezeigt).

Anzahl und Größe der entsprechenden Gewindebohrungen am Wellenende sind von den Anwendungsanforderungen abhängig.

MB

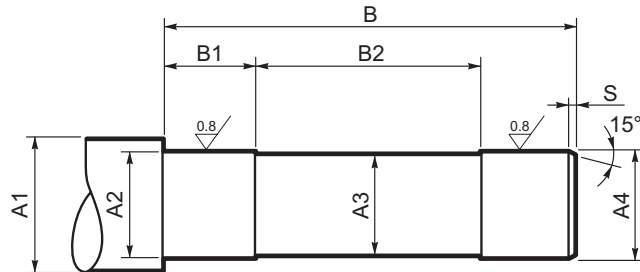

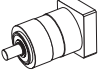
	A1	A2	A3	A4	B	B1	B2	S
MP MB 080	≥ 25	20 h7	18	20 h7	178	50	90	1
MP MB 105	≥ 40	32 h7	30	32 h7	205	60	115	
MP MB 130/160	≥ 50	42 h7	40	42 h7	259	70	140	

MP

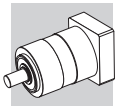

LC KOAXIALE PRÄZISIONSPLANETENGETRIEBE

LC-Präzisionsplanetengetriebe sind dank optimaler Leistungsfähigkeit und Zuverlässigkeit eine flexible Lösung und wirtschaftliche Alternative.

Verbesserte Leistungsfähigkeit als Schlüssel zum Downsizing.

Die verbesserte Leistungsfähigkeit unseres LC-Präzisionsgetriebes (neue Option "P") kann wichtige Downsizing-Optionen für zahlreiche Anwendungen eröffnen, bei denen es zuvor nicht möglich war, ein höheres übertragbares Abtriebsdrehmoment bereitzustellen.

Ein weiterer Vorteil des Downsizing ist eine verbesserte Energieeffizienz, indem man ein kompakteres Getriebe mit höherer Drehmomentdichte wählen und dadurch die Beschleunigungsmasse deutlich reduzieren kann. Das übertragbare Drehmoment wurde um bis zu 40% verbessert.

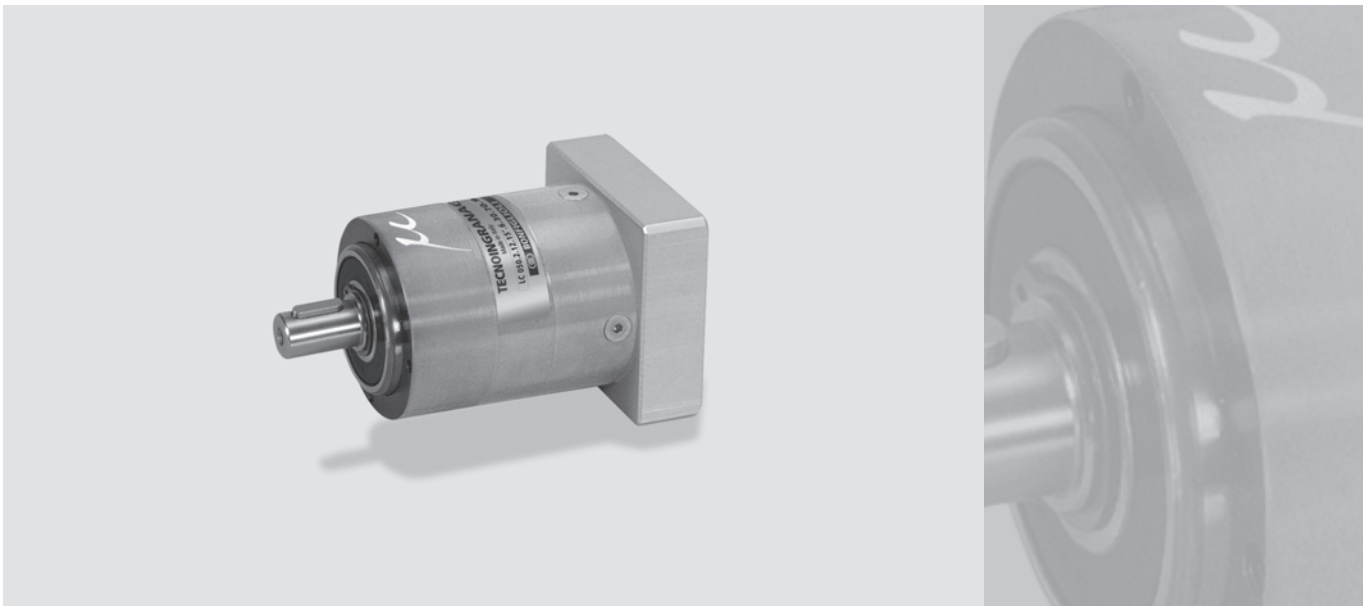

LC

Produktmerkmale:

- Option "P" mit hoher Drehmomentdichte für eine größere Produktleistungsfähigkeit verfügbar
- Optimales Beschleunigungs- und Nenndrehmoment
- Optimale radiale und axiale Belastbarkeit
- Entwickelt für Zyklus- und Dauerbetrieb
- Optimale Verdrehsteifigkeit
- Verdrehflankenspiel – unter 6 arcmin
- Einsetzbar in beliebiger Montageposition



7 MERKMALE DER LC-REIHE

Die Planetengetriebe der LC-Reihe zeichnen sich durch geringes Verdrehspiel, hohes übertragbares Drehmoment und hohe Getriebeübersetzungen aus.

Alle Getriebe sind laufruhig und gewährleisten eine lange und wartungsarme Nutzungsdauer. Die Motormontage ist einfach und erfordert keinerlei Spezialwerkzeug.

- Erhältlich entweder mit standard (STD) oder reduziertem (LOW) Flankenspiel:
1-stufige Getriebe: standard $\varphi_S \leq 12'$; reduziert $\varphi_R \leq 6'$
2-stufige Getriebe: standard $\varphi_S \leq 15'$; reduziert $\varphi_R \leq 8'$
- Eine hohe IP-Schutzklasse (IP64) sorgt dafür, dass innenliegende Teile vor Staub- und Flüssigkeitseintritt geschützt sind.
- Serienmäßige Fluorelastomer-Wellendichtungen an der Eingangswelle
- Schalldruckpegel $L_P \leq 70$ dB(A). Gemessen in 1 m Abstand ohne Last und bei einer Eingangsrehzahl von $n_1 = 3000 \text{ min}^{-1}$; $i=10$.
- Große Auswahl an Motoradaptern sorgt für den Anschluss an die marktgängigsten Servomotoren.
- Die Getriebe sind werksseitig mit synthetischem Schmierfett gemäß NLGI-Konsistenzklasse 00 gefüllt; ohne Verunreinigung muss das Schmiermittel nicht regelmäßig gewechselt werden.
- Umgebungstemperatur min. -20°C , max. $+30^\circ\text{C}$; bei Temperaturen höher als 30°C ist der Temperaturfaktor f_T zu berücksichtigen.
- Die Gehäusetemperatur darf $T_{\text{max}} = 90^\circ\text{C}$ nicht übersteigen.
- Erhältlich als Version P mit höherem Abtriebsdrehmoment.

Übersicht der Nenn Drehmomente M_{n2} [Nm]																					
[i]	3	4	5	7	9	10	12	15	16	20	25	28	30	35	36	40	45	50	70	81	100
LC 050	10	12	12	12	10	-	12	12	12	12	12	12	-	12	12	-	12	-	-	10	-
LC 070	18	25	25	25	18	18	25	25	25	25	25	25	18	25	-	25	-	25	25	-	18
LC 070P	29	30	25	25	29	18	29	29	30	30	30	30	29	30	-	30	-	30	30	-	18
LC 090	37	43	43	43	37	37	43	43	43	43	43	43	37	43	-	43	-	43	43	-	37
LC 090P	65	60	50	50	65	40	65	65	60	60	50	50	65	50	-	60	-	50	50	-	40
LC 120	95	110	110	110	95	95	110	110	110	110	110	110	95	110	-	110	-	110	110	-	95
LC 120P	155	155	125	125	155	100	155	155	155	155	125	125	155	125	-	155	-	125	125	-	100
LC 155	250	300	300	300	250	230	300	300	300	300	300	300	250	300	-	300	-	300	300	-	230
LC 155P	250	350	350	350	250	230	450	450	450	450	450	450	250	450	-	450	-	450	450	-	230

LC

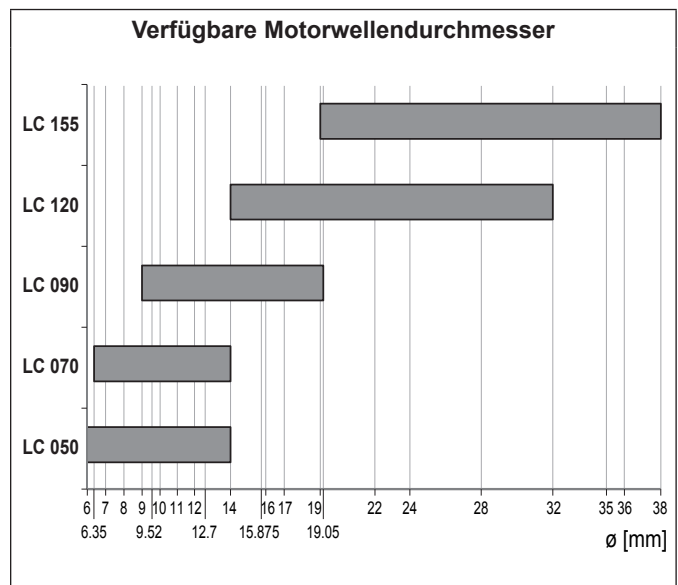
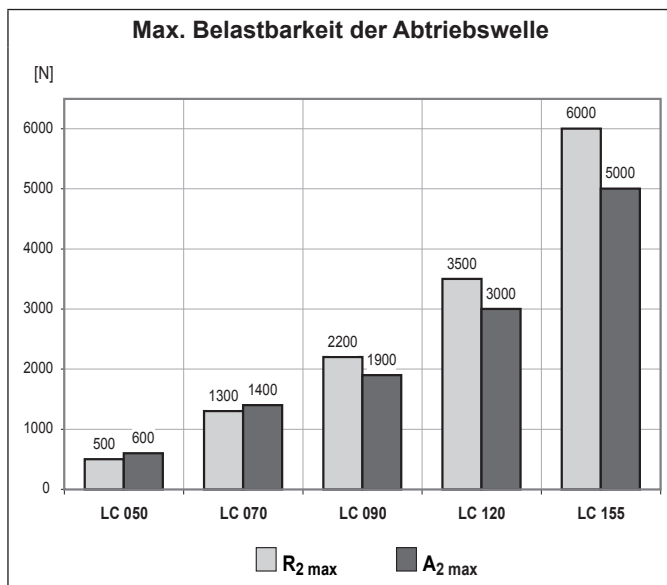

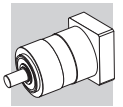

7.1 BESTELLBEZEICHNUNG

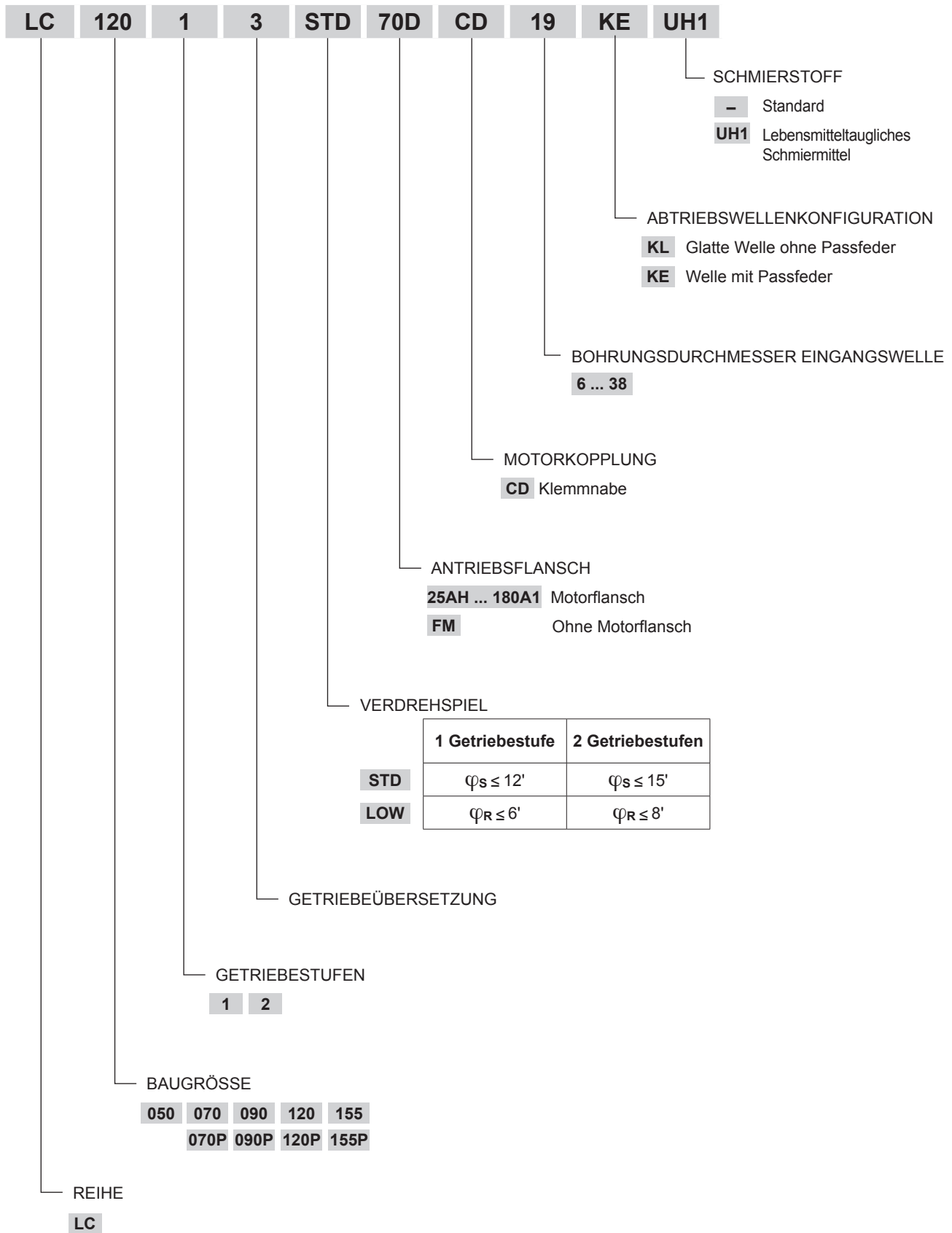



7.2 ABMESSUNGEN UND TECHNISCHE DATEN

LC 050

25AH ... 80A

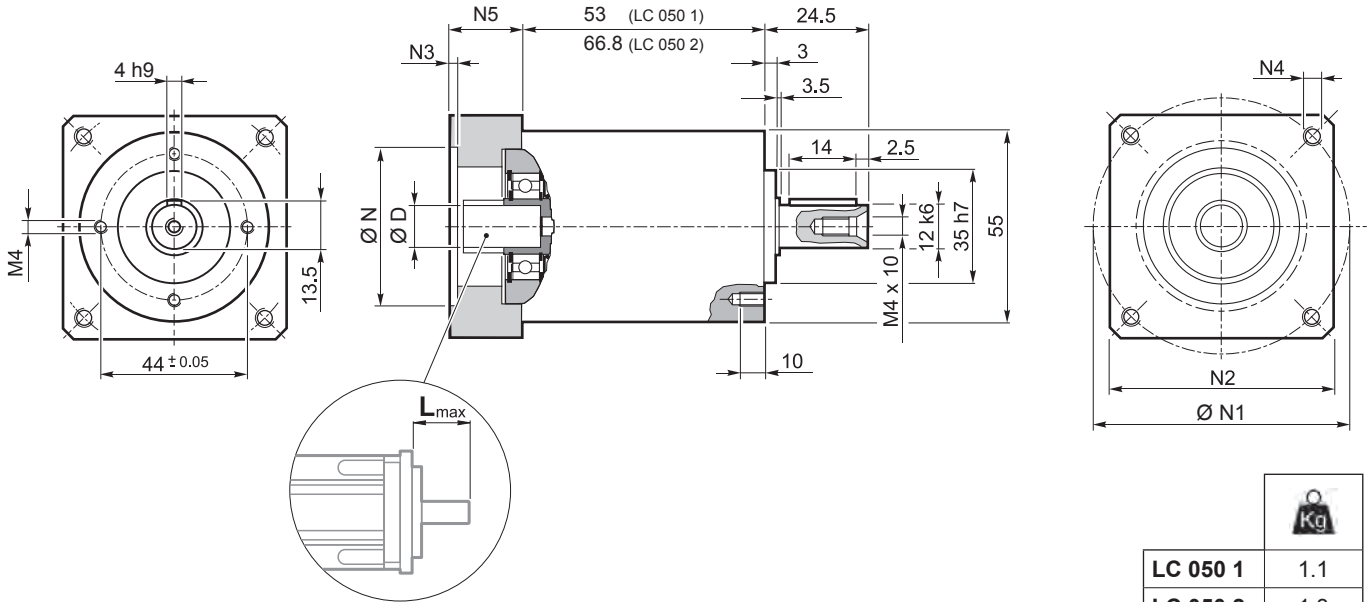

											N	N1		N2	N3	N4	N5	L _{max}
	min	max																
25AH	6	6.35	7	8	9	9.52	-	-	-	-	25	36	48	55	3.5	4.5	25	25
26AH	6	6.35	7	8	9	9.52	-	-	-	-	26	36	48					
28AH	6	6.35	7	8	9	9.52	-	-	-	-	28	36	48					
30AH	6	6.35	7	8	9	9.52	-	-	-	-	30	36	48					
32AH	6	6.35	7	8	9	9.52	-	-	-	-	32	38	48					
34AH	6	6.35	7	8	9	9.52	-	-	-	-	34	40	48					
36AH	6	6.35	7	8	9	9.52	-	-	-	-	36	42	48					
38AH	6	6.35	7	8	9	9.52	-	-	-	-	38	44	48					
40AH	6	6.35	7	8	9	9.52	-	-	-	-	40	46	48					
38B	6	6.35	7	8	9	9.52	10	11	12	12.7	-	38.1	66.6	60	3	M4x10	18	25
40B	6	6.35	7	8	9	9.52	10	11	12	12.7	-	40	63	60	3	M4x10	18	25
50A	6	6.35	7	8	9	9.52	10	11	12	12.7	-	50	60	60	3	M4x10	18	25
50B	6	6.35	7	8	9	9.52	10	11	12	12.7	14	50	65	60	3	M5x12	23	30
50BH	6	6.35	7	8	9	9.52	10	11	12	12.7	14	50	65	60	4	5.5	23	30
50C	6	6.35	7	8	9	9.52	10	11	12	12.7	14	50	70	60	3	M4x10	23	30
50MH	6	6.35	7	8	9	9.52	10	11	12	12.7	-	50	65	55	4	5.5	16	23
60A	6	6.35	7	8	9	9.52	10	11	12	12.7	-	60	75	65	3	M5x12	18	25
60AH	6	6.35	7	8	9	9.52	10	11	12	12.7	-	60	75	65	3	5.5	18	25
60A1	6	6.35	7	8	9	9.52	10	11	12	12.7	14	60	75	65	3	M5x12	23	30
60AH1	6	6.35	7	8	9	9.52	10	11	12	12.7	14	60	75	65	3	5.5	23	30
60B	6	6.35	7	8	9	9.52	10	11	12	12.7	14	60	85	75	3	M5x12	23	30
60C	6	6.35	7	8	9	9.52	10	11	12	12.7	14	60	90	75	3	M5x12	23	30
70A	6	6.35	7	8	9	9.52	10	11	12	12.7	14	70	85	75	3	M6x15	23	30
70B	6	6.35	7	8	9	9.52	10	11	12	12.7	14	70	90	75	3	M5x12	23	30
73A	6	6.35	7	8	9	9.52	10	11	12	12.7	14	73	98.4	85	3	M5x12	25	32
80A	6	6.35	7	8	9	9.52	10	11	12	12.7	14	80	100	85	3	M6x15	23	30

Für weitere Motoradapter und Antriebswellenbohrungen bitte nachfragen.

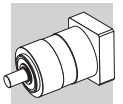

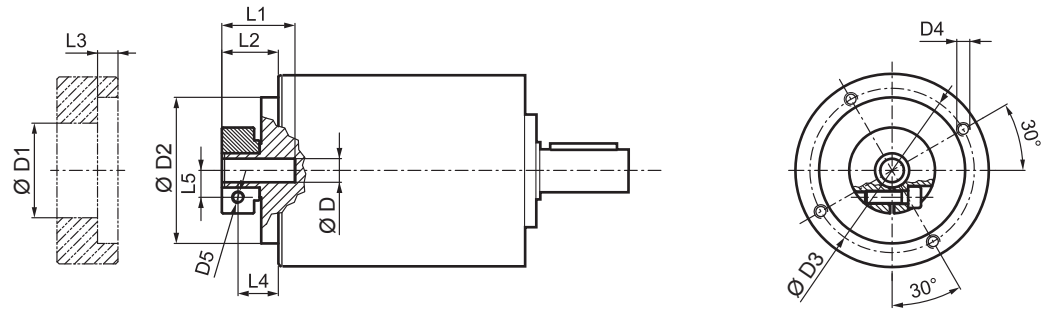

LC 050

FM

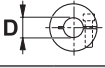

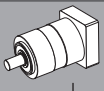
				D1	D2	D3	D4	D5	L1	L2	L3	L4	L5
6	6.35	7		32.5	50	42.5	M4x8	M4	21.7	13.2	3	8.2	8
8	9	9.52	10	32.5	50	42.5	M4x8	M4	21.7	13.2	3	8.2	9
11	12	12.7		35.5	50	42.5	M4x8	M4	22	13.5	3	8.5	11
14				35.5	50	42.5	M4x8	M4	25	17	3	10.2	11.5

	M _{n2} [Nm]	M _{a2} [Nm]	M _{p2} [Nm]	n ₁ [min ⁻¹]	n _{1 max} [min ⁻¹]	φ _S [arcmin]	φ _R [arcmin]	C _t [Nm/arcmin]	R _{2 max} [N]	A _{2 max} [N]	η %	J _G [kgcm ²]	
													6 ... 9.52
LC 050 1_3	10	16	28	3300	4000	12'	6'	0.9	500	600	97	0.07	0.10
LC 050 1_4	12	20	30	3500	5000	12'	6'	0.9	500	600	97	0.06	0.08
LC 050 1_5	12	20	30	3500	5000	12'	6'	0.9	500	600	97	0.05	0.07
LC 050 1_7	12	20	30	4000	5000	12'	6'	0.9	500	600	97	0.04	0.06
LC 050 1_9	10	16	28	4000	6000	12'	6'	0.9	500	600	97	0.04	0.06
LC 050 2_12	12	20	30	3300	4000	15'	8'	0.75	500	600	94	0.07	0.09
LC 050 2_15	12	20	30	3300	4000	15'	8'	0.75	500	600	94	0.07	0.09
LC 050 2_16	12	20	30	3500	5000	15'	8'	0.75	500	600	94	0.05	0.07
LC 050 2_20	12	20	30	3500	5000	15'	8'	0.75	500	600	94	0.05	0.07
LC 050 2_25	12	20	30	3500	5000	15'	8'	0.75	500	600	94	0.05	0.07
LC 050 2_28	12	20	30	4000	5000	15'	8'	0.75	500	600	94	0.04	0.06
LC 050 2_35	12	20	30	4000	5000	15'	8'	0.75	500	600	94	0.04	0.06
LC 050 2_36	12	20	30	4000	6000	15'	8'	0.75	500	600	94	0.04	0.06
LC 050 2_45	12	20	30	4000	6000	15'	8'	0.75	500	600	94	0.04	0.06
LC 050 2_81	10	16	28	4000	6000	15'	8'	0.75	500	600	94	0.04	0.06

LC



LC 070

25AH ... 80A

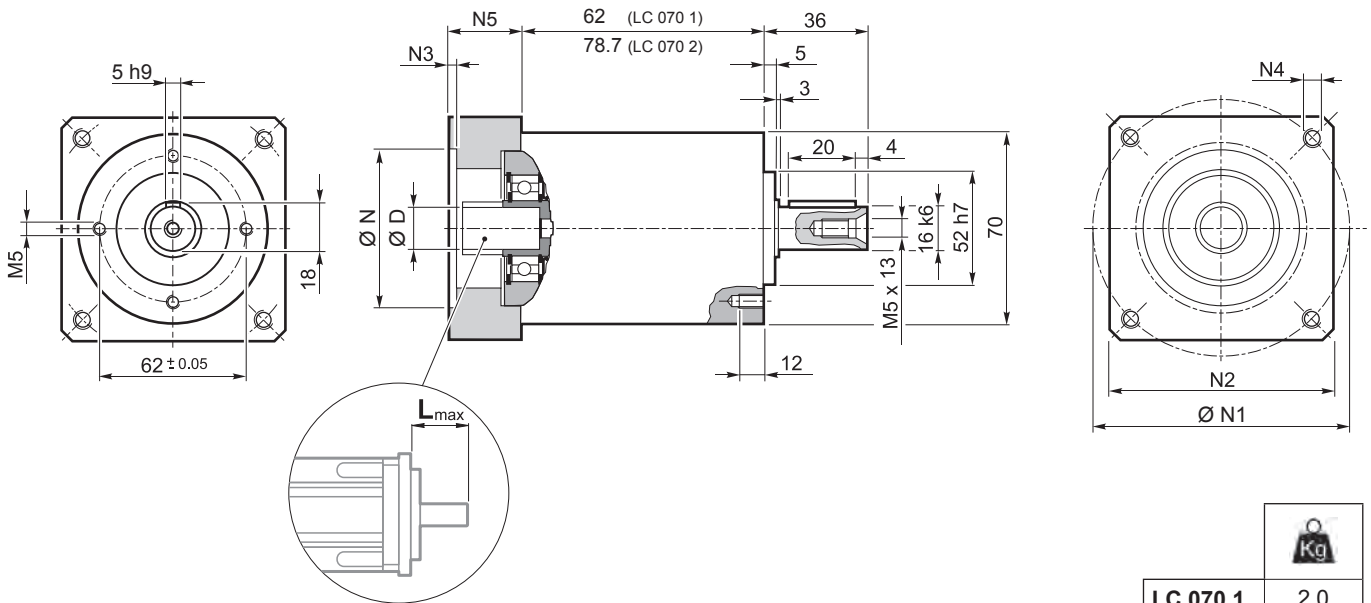

LC 070 1	2.0
LC 070 2	2.3

											N	N1		N2	N3	N4	N5	L _{max}
	min	max																
25AH	6.35	7	8	9	9.52	-	-	-	-	-	25	39	56	65	3.5	4.5	25	25
26AH	6.35	7	8	9	9.52	-	-	-	-	-	26	39	56					
28AH	6.35	7	8	9	9.52	-	-	-	-	-	28	39	56					
30AH	6.35	7	8	9	9.52	-	-	-	-	-	30	39	56					
32AH	6.35	7	8	9	9.52	-	-	-	-	-	32	39	56					
34AH	6.35	7	8	9	9.52	-	-	-	-	-	34	40	56					
36AH	6.35	7	8	9	9.52	-	-	-	-	-	36	42	56					
39AH	6.35	7	8	9	9.52	-	-	-	-	-	39	45	56					
40AH	6.35	7	8	9	9.52	-	-	-	-	-	40	46	56					
38B	6.35	7	8	9	9.52	10	11	12	12.7	-	38.1	66.6	60	3	M4x10	18	25	
40B	6.35	7	8	9	9.52	10	11	12	12.7	-	40	63	60	3	M4x10	18	25	
50A	6.35	7	8	9	9.52	10	11	12	12.7	-	50	60	60	3	M4x10	18	25	
50B	6.35	7	8	9	9.52	10	11	12	12.7	14	50	65	60	3	M5x12	23	30	
50BH	6.35	7	8	9	9.52	10	11	12	12.7	14	50	65	65	3	5.5	25	32	
50C	6.35	7	8	9	9.52	10	11	12	12.7	14	50	70	60	3	M4x10	23	30	
55MH	6.35	7	8	9	9.52	10	11	12	12.7	-	55	80	65	2	5.5	16	23	
60A	6.35	7	8	9	9.52	10	11	12	12.7	-	60	75	65	3	M5x12	18	25	
60A1	6.35	7	8	9	9.52	10	11	12	12.7	14	60	75	65	3	M5x12	23	30	
60B	6.35	7	8	9	9.52	10	11	12	12.7	14	60	85	75	3	M5x12	23	30	
60C	6.35	7	8	9	9.52	10	11	12	12.7	14	60	90	75	3	M5x12	23	30	
70A	6.35	7	8	9	9.52	10	11	12	12.7	14	70	85	75	3	M6x15	23	30	
70B	6.35	7	8	9	9.52	10	11	12	12.7	14	70	90	75	3	M5x12	23	30	
73A	6.35	7	8	9	9.52	10	11	12	12.7	14	73	98.4	85	3	M5x12	25	32	
80A	6.35	7	8	9	9.52	10	11	12	12.7	14	80	100	85	3	M6x15	23	30	

Für weitere Motoradapter und Antriebswellenbohrungen bitte nachfragen.

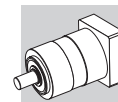

LC 070

FM

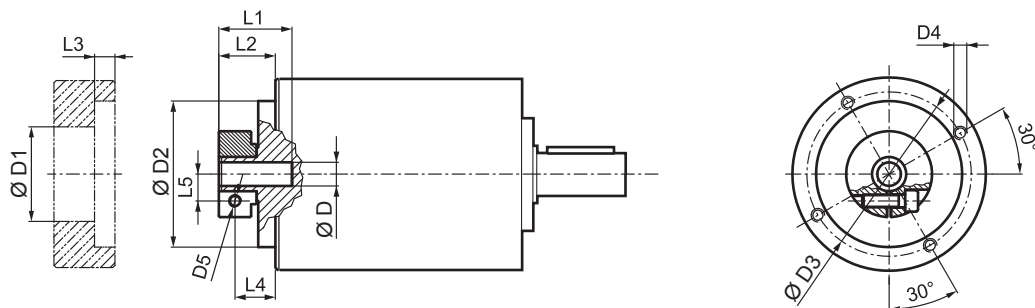

				D1	D2	D3	D4	D5	L1	L2	L3	L4	L5
6.35	7			32.5	50	42.5	M4x8	M4	21.7	13.2	3	8.2	8
8	9	9.52	10	32.5	50	42.5	M4x8	M4	21.7	13.2	3	8.2	9
11	12	12.7		35.5	50	42.5	M4x8	M4	22	13.5	3	8.5	11
14				35.5	50	42.5	M4x8	M4	25	17	3	10.2	11.5

	i	M _{n 2}	M _{a 2}	M _{p 2}	n ₁	n _{1 max}	φ _S	φ _R	C _t	R _{2 max}	A _{2 max}	η	J _G [kgcm ²]	
		[Nm]	[Nm]	[Nm]	[min ⁻¹]	[min ⁻¹]	[arcmin]		$\left[\frac{\text{Nm}}{\text{arcmin}} \right]$	[N]	[N]	%	6.35 ... 9.52	10 ... 14
LC 070 1_3		18	30	60	3300	4000	12'	6'	3	1300	1400	97	0.12	0.14
LC 070 1_4		25	35	70	3500	5000	12'	6'	3	1300	1400	97	0.08	0.10
LC 070 1_5		25	35	70	3500	5000	12'	6'	3	1300	1400	97	0.06	0.09
LC 070 1_7		25	35	70	4000	5000	12'	6'	3	1300	1400	97	0.05	0.07
LC 070 1_10		18	30	60	4000	6000	12'	6'	3	1300	1400	97	0.04	0.06
LC 070 2_9		18	30	60	3300	4000	15'	8'	2.5	1300	1400	94	0.11	0.13
LC 070 2_12		25	35	70	3300	4000	15'	8'	2.5	1300	1400	94	0.10	0.13
LC 070 2_15		25	35	70	3300	4000	15'	8'	2.5	1300	1400	94	0.10	0.12
LC 070 2_16		25	35	70	3500	5000	15'	8'	2.5	1300	1400	94	0.07	0.09
LC 070 2_20		25	35	70	3500	5000	15'	8'	2.5	1300	1400	94	0.06	0.08
LC 070 2_25		25	35	70	3500	5000	15'	8'	2.5	1300	1400	94	0.06	0.08
LC 070 2_28		25	35	70	4000	5000	15'	8'	2.5	1300	1400	94	0.05	0.07
LC 070 2_30		18	30	60	4000	6000	15'	8'	2.5	1300	1400	94	0.04	0.06
LC 070 2_35		25	35	70	4000	5000	15'	8'	2.5	1300	1400	94	0.05	0.07
LC 070 2_40		25	35	70	4000	6000	15'	8'	2.5	1300	1400	94	0.04	0.06
LC 070 2_50		25	35	70	4000	6000	15'	8'	2.5	1300	1400	94	0.04	0.06
LC 070 2_70		25	35	70	4000	6000	15'	8'	2.5	1300	1400	94	0.04	0.06
LC 070 2_100		18	30	60	4000	6000	15'	8'	2.5	1300	1400	94	0.04	0.06

LC



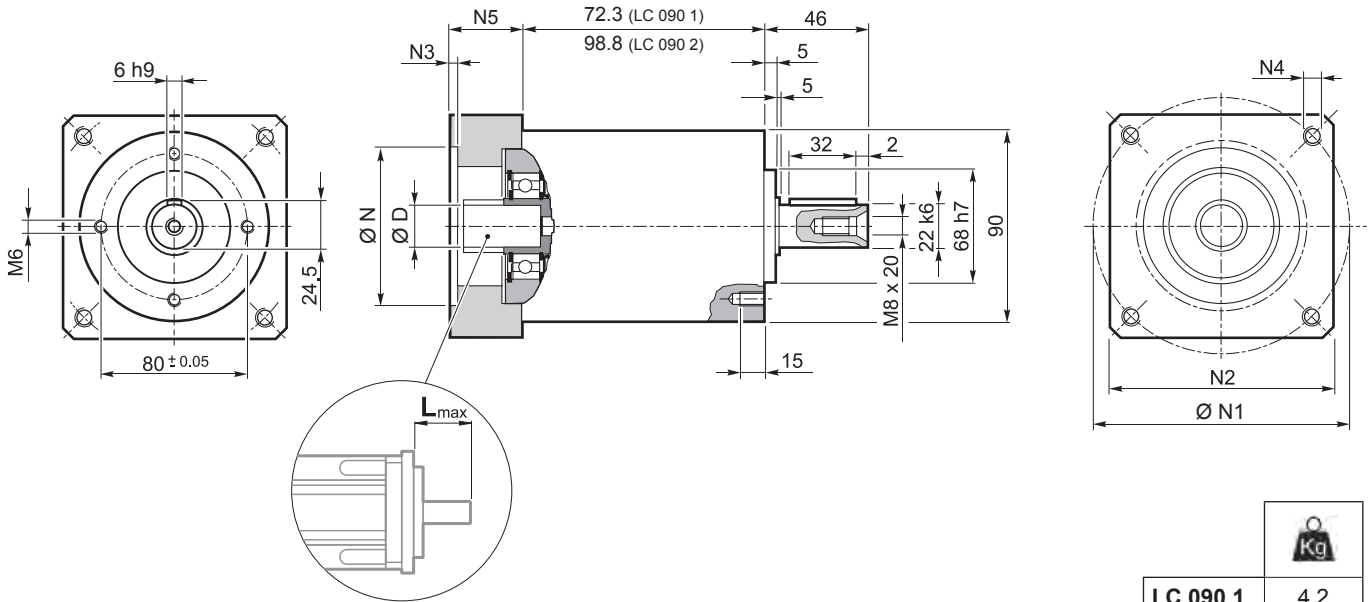

LC 090

40B1 ... 110B1



	
LC 090 1	4.2
LC 090 2	5.3

												N	N1	N2	N3	N4	N5	L _{max}
40B1	9	9.52	11	12	12.7	14	-	-	-	-	-	40	63	80	4	M4x10	34	40
45A	9	9.52	11	12	12.7	-	-	-	-	-	-	45	63	80	4	M4x10	34	40
50B1	9	9.52	11	12	12.7	14	-	-	-	-	-	50	65	80	4	M5x16	34	40
50BH1	9	9.52	11	12	12.7	14	-	-	-	-	-	50	65	80	4	5.5	34	40
50C1	9	9.52	11	12	12.7	14	-	-	-	-	-	50	70	80	4	M4x10	34	40
50D	9	9.52	11	12	12.7	14	-	-	-	-	-	50	95	80	4	M6x10	34	40
55A	9	9.52	11	12	12.7	14	15.875	16	17	19	19.05	55.5	125.7	105	4	M6x16	34	40
60A2	9	9.52	11	12	12.7	14	-	-	-	-	-	60	75	80	4	M5x16	34	40
60AH2	9	9.52	11	12	12.7	14	-	-	-	-	-	60	75	90	4	5.5	34	40
60B1	9	9.52	11	12	12.7	14	15.875	16	-	-	-	60	85	80	4	M5x16	34	40
60C1	9	9.52	11	12	12.7	14	15.875	16	-	-	-	60	90	80	4	M5x16	34	40
70A1	9	9.52	11	12	12.7	14	15.875	16	17	19	19.05	70	85	80	4	M6x20	34	40
70AH1	9	9.52	11	12	12.7	14	15.875	16	17	19	19.05	70	85	90	4	6.5	34	40
70B1	9	9.52	11	12	12.7	14	15.875	16	17	19	19.05	70	90	80	4	M5x16	34	40
73A1	9	9.52	11	12	12.7	14	-	-	-	-	-	73	98.4	85	4	M5x16	34	40
80A1	9	9.52	11	12	12.7	14	15.875	16	17	19	19.05	80	100	90	4	M6x16	34	40
95A	9	9.52	11	12	12.7	14	15.875	16	17	19	19.05	95	115	100	4	M8x20	34	40
95B	9	9.52	11	12	12.7	14	15.875	16	17	19	19.05	95	130	115	4	M8x20	34	40
110A	9	9.52	11	12	12.7	14	15.875	16	17	19	19.05	110	130	115	4	M8x20	34	40
110B	9	9.52	11	12	12.7	14	15.875	16	17	19	19.05	110	145	120	6.5	M8x20	44	50
110B1	9	9.52	11	12	12.7	14	15.875	16	17	19	19.05	110	145	120	6.5	M8x20	54	60

Für weitere Motoradapter und Antriebswellenbohrungen bitte nachfragen.

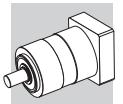

LC 090

FM

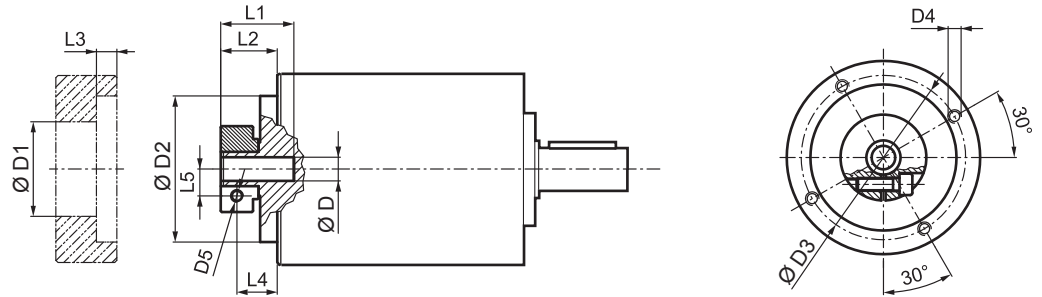

D	D			D1	D2	D3	D4	D5	L1	L2	L3	L4	L5
	9	11	14										
9	9.52			38	68	76.5	M6x10	M6	34	26.8	9.5	18.8	10.5
11	12	12.7		43	68	76.5	M6x10	M6	34	26.8	9.5	18.8	12.5
14	15.875	16	17	48	68	76.5	M6x10	M6	34	26.8	9.5	18.8	14.5
19	19.05			51	68	76.5	M6x10	M6	34	26.8	9.5	18.8	16.5

i	M _{n 2} [Nm]	M _{a 2} [Nm]	M _{p 2} [Nm]	n ₁ [min ⁻¹]	n _{1 max} [min ⁻¹]	φ _S [arcmin]	φ _R [arcmin]	C _t [Nm/arcmin]	R _{2 max} [N]	A _{2 max} [N]	η %	J _G [kgcm ²]	
												9 ... 12.7	14 ... 19.05
LC 090 1_3	37	70	150	2900	3500	12'	6'	9	2200	1900	97	0.62	0.77
LC 090 1_4	43	80	160	3100	4500	12'	6'	9	2200	1900	97	0.41	0.55
LC 090 1_5	43	80	160	3200	4500	12'	6'	9	2200	1900	97	0.33	0.47
LC 090 1_7	43	80	160	4000	4500	12'	6'	9	2200	1900	97	0.26	0.40
LC 090 1_10	37	70	150	4000	6000	12'	6'	9	2200	1900	97	0.21	0.35
LC 090 2_9	37	70	150	2900	3500	15'	8'	8.5	2200	1900	94	0.47	0.61
LC 090 2_12	43	80	160	2900	3500	15'	8'	8.5	2200	1900	94	0.44	0.58
LC 090 2_15	43	80	160	2900	3500	15'	8'	8.5	2200	1900	94	0.43	0.57
LC 090 2_16	43	80	160	3100	4500	15'	8'	8.5	2200	1900	94	0.31	0.45
LC 090 2_20	43	80	160	3200	4500	15'	8'	8.5	2200	1900	94	0.26	0.40
LC 090 2_25	43	80	160	3200	4500	15'	8'	8.5	2200	1900	94	0.26	0.40
LC 090 2_28	43	80	160	4000	4500	15'	8'	8.5	2200	1900	94	0.22	0.36
LC 090 2_30	37	70	150	4000	6000	15'	8'	8.5	2200	1900	94	0.20	0.34
LC 090 2_35	43	80	160	4000	4500	15'	8'	8.5	2200	1900	94	0.22	0.36
LC 090 2_40	43	80	160	4000	6000	15'	8'	8.5	2200	1900	94	0.20	0.34
LC 090 2_50	43	80	160	4000	6000	15'	8'	8.5	2200	1900	94	0.20	0.34
LC 090 2_70	43	80	160	4000	6000	15'	8'	8.5	2200	1900	94	0.20	0.34
LC 090 2_100	37	70	150	4000	6000	15'	8'	8.5	2200	1900	94	0.19	0.34

LC



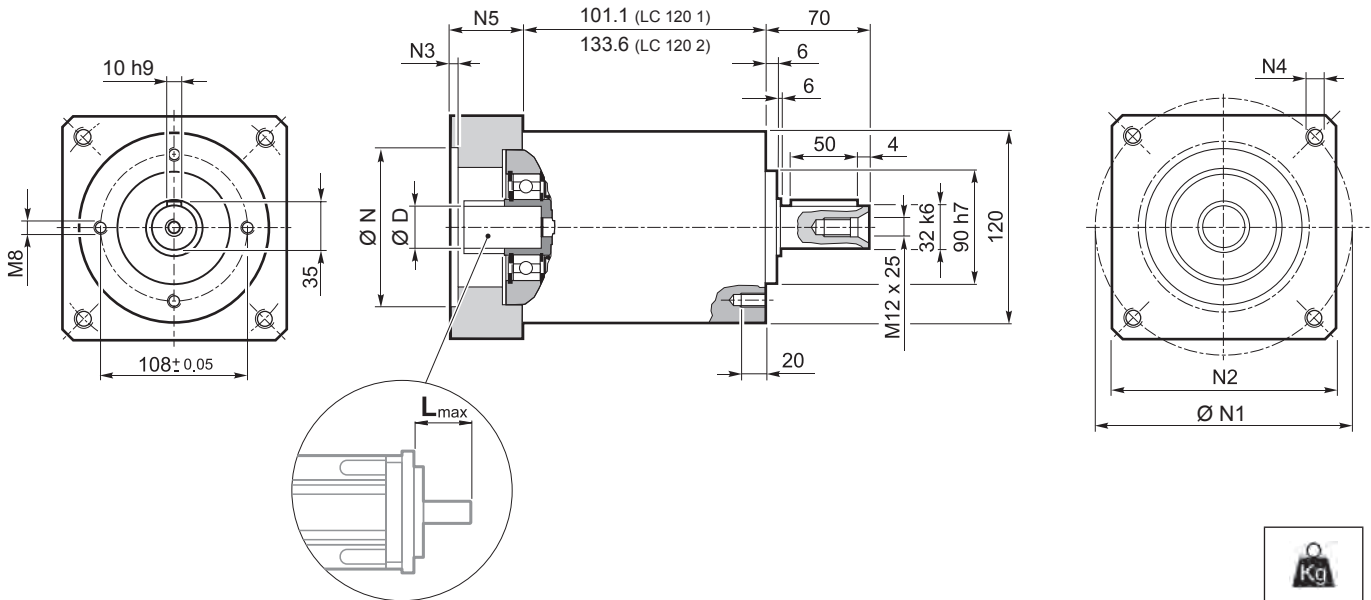

LC 120

50D ... 130A1



	
LC 120 1	9.6
LC 120 2	12.1

										N	N1	N2	N3	N4	N5	L _{max}
50D	14	15	15.875	16	19	-	-	-	-	50	95	100	5	M6x14	28	40
55A	14	15	15.875	16	19	-	-	-	-	55.5	125.7	105	5	M6x16	28	40
60A2	14	15	15.875	16	19	-	-	-	-	60	75	100	5	M5x14	28	40
60AH2	14	15	15.875	16	19	-	-	-	-	60	75	100	5	6.5	33	40
60B1	14	15	15.875	16	19	-	-	-	-	60	85	100	6.5	M5x14	28	40
70A1	14	15	15.875	16	19	-	-	-	-	70	85	100	5	M6x14	28	40
70AH1	14	15	15.875	16	19	-	-	-	-	70	85	100	5	6	33	40
70B1	14	15	15.875	16	19	-	-	-	-	70	90	100	5	M5x12	28	40
80A1	14	15	15.875	16	19	-	-	-	-	80	100	100	5	M6x16	28	40
80AH1	14	15	15.875	16	19	-	-	-	-	80	100	100	5	6.5	28	40
95A	14	15	15.875	16	19	-	-	-	-	95	115	100	5	M8x18	28	40
95A1	14	15	15.875	16	19	22	24	-	-	95	115	100	5	M8x18	38	50
95B	14	15	15.875	16	19	-	-	-	-	95	130	115	5	M8x18	28	40
110A	14	15	15.875	16	19	-	-	-	-	110	130	115	5	M8x18	28	40
110A1	14	15	15.875	16	19	22	24	-	-	110	130	115	6.5	M8x20	38	50
110B	14	15	15.875	16	19	22	24	-	-	110	145	120	6.5	M8x20	38	50
110B1	14	15	15.875	16	19	22	24	28	-	110	145	120	6.5	M8x20	48	60
130A	14	15	15.875	16	19	22	24	-	-	130	165	140	6.5	M10x20	38	50
130A1	14	15	15.875	16	19	22	24	28	32	130	165	140	6.5	M10x25	48	60

Für weitere Motoradapter und Antriebswellenbohrungen bitte nachfragen.

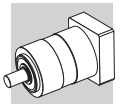

LC 120

FM

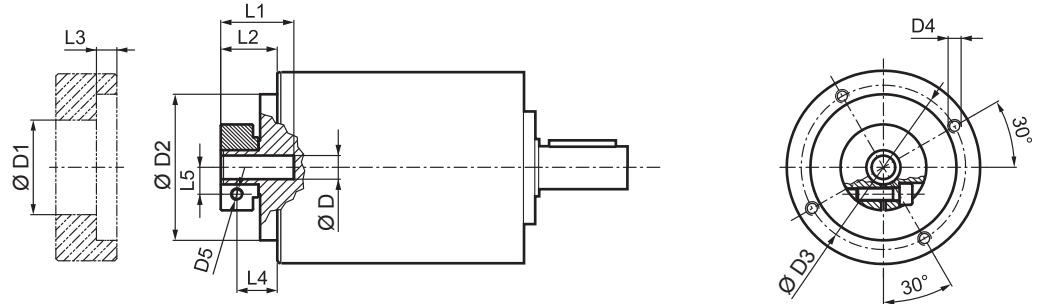

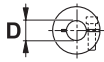
				D1	D2	D3	D4	D5	L1	L2	L3	L4	L5
14	15	15.875	16	48	90	98	M6x15	M6	33.5	20	7.6	12.5	14.5
19				51	90	98	M6x15	M6	33.5	20	7.6	12.5	16.5
22	24			56.5	90	98	M6x15	M6	36.5	23	7.6	14	19
28				67	90	98	M6x15	M8	36.5	23	7.6	14	22.5
32				71	90	98	M6x15	M8	38	24.5	7.6	15.5	24.5

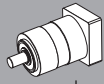
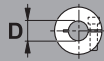
	i	M _{n2} [Nm]	M _{a2} [Nm]	M _{p2} [Nm]	n ₁ [min ⁻¹]	n _{1 max} [min ⁻¹]	φ _S [arcmin]	φ _R [arcmin]	C _t [Nm/arcmin]	R _{2 max} [N]	A _{2 max} [N]	η %	J _G [kgcm ²]		
															
LC 120 1_3		95	160	300	2500	3500	12'	6'	25	3500	3000	97	14 ... 19	22 ; 24	28 ; 32
LC 120 1_4		110	190	360	2800	4500	12'	6'	25	3500	3000	97	1.30	1.89	2.26
LC 120 1_5		110	190	360	3000	4500	12'	6'	25	3500	3000	97	0.96	1.56	1.92
LC 120 1_7		110	190	360	3500	4500	12'	6'	25	3500	3000	97	0.66	1.26	1.62
LC 120 1_10		95	160	300	3500	5000	12'	6'	25	3500	3000	97	0.49	1.09	1.45
LC 120 2_9		95	160	300	2500	3500	15'	8'	22.5	3500	3000	94	1.61	2.20	2.57
LC 120 2_12		110	190	360	2500	3500	15'	8'	22.5	3500	3000	94	1.51	2.10	2.47
LC 120 2_15		110	190	360	2500	3500	15'	8'	22.5	3500	3000	94	1.47	2.06	2.43
LC 120 2_16		110	190	360	2800	4500	15'	8'	22.5	3500	3000	94	0.92	1.52	1.88
LC 120 2_20		110	190	360	3000	4500	15'	8'	22.5	3500	3000	94	0.90	1.50	1.86
LC 120 2_25		110	190	360	3000	4500	15'	8'	22.5	3500	3000	94	0.71	1.30	1.67
LC 120 2_28		110	190	360	3500	4500	15'	8'	22.5	3500	3000	94	0.54	1.13	1.50
LC 120 2_30		95	160	300	3500	5000	15'	8'	22.5	3500	3000	94	0.44	1.04	1.40
LC 120 2_35		110	190	360	3500	4500	15'	8'	22.5	3500	3000	94	0.53	1.13	1.49
LC 120 2_40		110	190	360	3500	5000	15'	8'	22.5	3500	3000	94	0.43	1.03	1.39
LC 120 2_50		110	190	360	3500	5000	15'	8'	22.5	3500	3000	94	0.43	1.02	1.39
LC 120 2_70		110	190	360	3500	5000	15'	8'	22.5	3500	3000	94	0.42	1.02	1.38
LC 120 2_100		95	160	300	3500	5000	15'	8'	22.5	3500	3000	94	0.42	1.02	1.38

LC



LC 155

55A1 ... 180A1

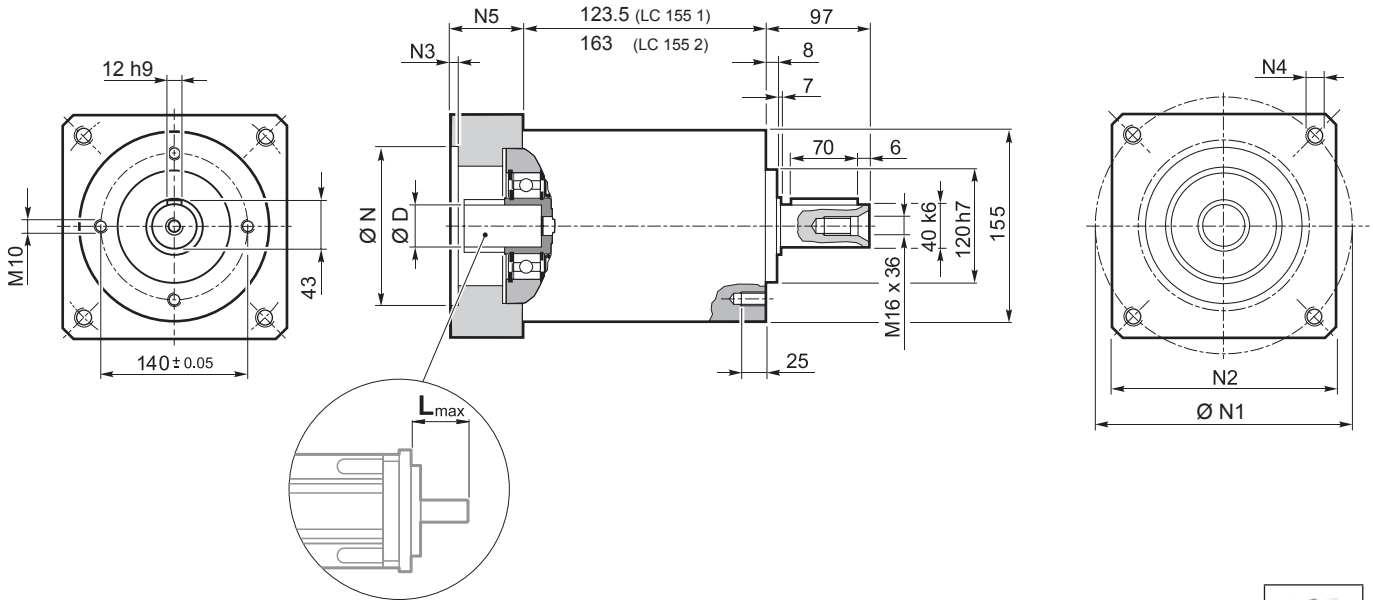

LC 155 1	19.3
LC 155 2	24.3

LC

								N	N1	N2	N3	N4	N5	L _{max}
55A1	19	-	-	-	-	-	55.5	125.7	130	4	M6x15	39.5	50	
80A2	19	-	-	-	-	-	80	100	130	4	M6x15	39.5	50	
95A1	19	22	24	-	-	-	95	115	130	4	M8x20	39.5	50	
110A1	19	22	24	-	-	-	110	130	130	4	M8x20	39.5	50	
110B1	19	22	24	-	-	-	110	145	130	6.5	M8x20	49.5	60	
114A	19	22	24	28	32	35	114.3	200	170	5.5	M12x25	69.5	80	
130A	19	22	24	-	-	-	130	165	140	4	M10x20	39.5	50	
130A1	19	22	24	28	32	-	130	165	140	4	M10x20	49.5	60	
180A	19	22	24	28	32	-	180	215	190	5.5	M14x25	49.5	60	
180A1	19	22	24	28	32	35	180	215	190	5.5	M14x25	69.5	80	

Für weitere Motoradapter und Antriebswellenbohrungen bitte nachfragen.

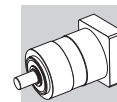

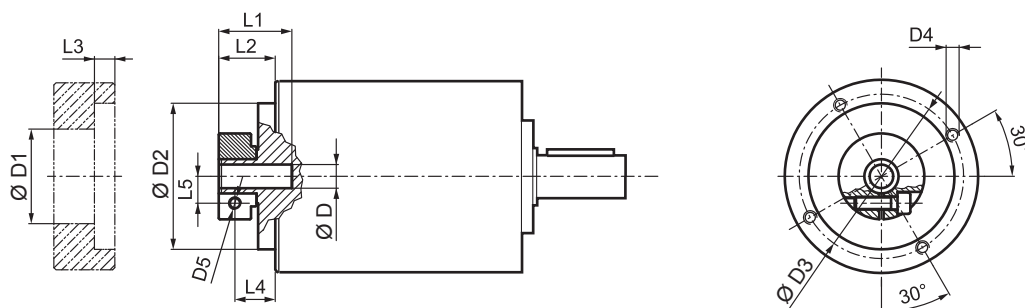

LC 155

FM

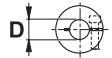

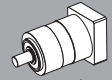
	D1	D2	D3	D4	D5	L1	L2	L3	L4	L5
19	51	113	125.5	M8x15	M6	40	27.5	6	20	16.5
22 24	56.5	113	125.5	M8x15	M6	41	28.5	6	19.5	19
28	67	113	125.5	M8x15	M8	41	28.5	6	19.5	22.5
32	71	113	125.5	M8x15	M8	41	28.5	6	18.5	24.5
35	73	113	125.5	M8x15	M8	50	37.5	11.25	26	26
38	77.5	113	125.5	M8x15	M8	50	37.5	11.25	26	28

	M _{n2} [Nm]	M _{a2} [Nm]	M _{p2} [Nm]	n ₁ [min ⁻¹]	n _{1 max} [min ⁻¹]	φ _S [arcmin]	φ _R [arcmin]	C _t [$\frac{Nm}{arcmin}$]	R _{2 max} [N]	A _{2 max} [N]	η %	J _G [kgcm ²]			
													19	22 ; 24	28 ; 32
LC 155 1_3	250	380	600	2100	3600	12'	6'	43	6000	5000	97	7.99	8.19	8.54	9.90
LC 155 1_4	300	450	700	2400	3600	12'	6'	43	6000	5000	97	4.66	4.87	5.23	6.57
LC 155 1_5	300	450	900	2900	3600	12'	6'	43	6000	5000	97	3.32	3.53	3.88	5.23
LC 155 1_7	300	450	900	3200	3600	12'	6'	43	6000	5000	97	2.14	2.35	2.70	4.05
LC 155 1_10	230	350	750	3200	3600	12'	6'	43	6000	5000	97	1.45	1.66	2.01	3.36
LC 155 2_9	250	380	600	2100	3600	15'	8'	37.5	6000	5000	94	5.30	5.51	5.86	7.21
LC 155 2_12	300	450	700	2100	3600	15'	8'	37.5	6000	5000	94	4.93	5.14	5.49	6.84
LC 155 2_15	300	450	900	2100	3600	15'	8'	37.5	6000	5000	94	4.79	4.99	5.34	6.70
LC 155 2_16	300	450	700	2400	3600	15'	8'	37.5	6000	5000	94	2.97	3.18	3.53	4.88
LC 155 2_20	300	450	900	2900	3600	15'	8'	37.5	6000	5000	94	2.23	2.44	2.79	4.14
LC 155 2_25	300	450	900	2900	3600	15'	8'	37.5	6000	5000	94	2.18	2.39	2.74	4.09
LC 155 2_28	300	450	900	3200	3600	15'	8'	37.5	6000	5000	94	1.58	1.79	2.14	3.49
LC 155 2_30	250	380	600	3200	3600	15'	8'	37.5	6000	5000	94	1.23	1.44	1.79	3.14
LC 155 2_35	300	450	900	3200	3600	15'	8'	37.5	6000	5000	94	1.55	1.76	2.11	3.46
LC 155 2_40	300	450	700	3200	3600	15'	8'	37.5	6000	5000	94	1.20	1.41	1.76	3.11
LC 155 2_50	300	450	900	3200	3600	15'	8'	37.5	6000	5000	94	1.19	1.39	1.74	3.10
LC 155 2_70	300	450	900	3200	3600	15'	8'	37.5	6000	5000	94	1.17	1.38	1.73	3.08
LC 155 2_100	230	350	750	3200	3600	15'	8'	37.5	6000	5000	94	1.17	1.38	1.73	3.08

LC



LC 070P

25AH ... 80A

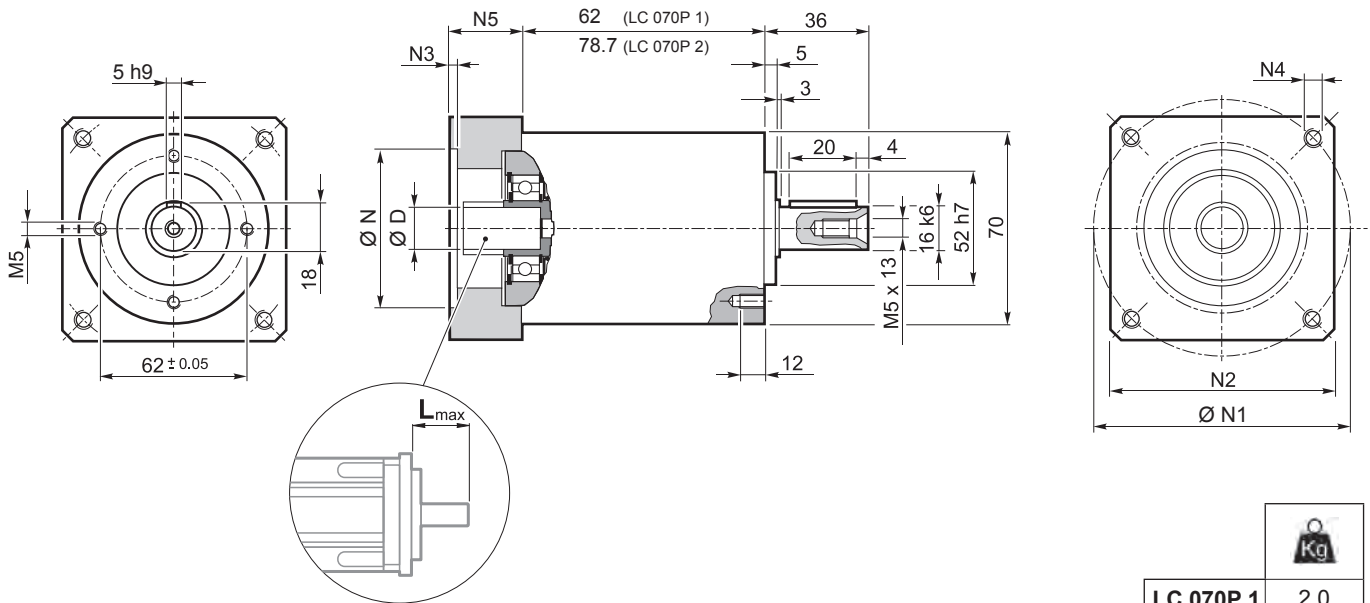

LC 070P 1	2.0
LC 070P 2	2.3

	D										N	N1		N2	N3	N4	N5	L _{max}
	6.35	7	8	9	9.52	10	11	12	12.7	14		min	max					
25AH	6.35	7	8	9	9.52	-	-	-	-	-	25	39	56					
26AH	6.35	7	8	9	9.52	-	-	-	-	-	26	39	56					
28AH	6.35	7	8	9	9.52	-	-	-	-	-	28	39	56					
30AH	6.35	7	8	9	9.52	-	-	-	-	-	30	39	56					
32AH	6.35	7	8	9	9.52	-	-	-	-	-	32	39	56	65	3.5	4.5	25	25
34AH	6.35	7	8	9	9.52	-	-	-	-	-	34	40	56					
36AH	6.35	7	8	9	9.52	-	-	-	-	-	36	42	56					
39AH	6.35	7	8	9	9.52	-	-	-	-	-	39	45	56					
40AH	6.35	7	8	9	9.52	-	-	-	-	-	40	46	56					
38B	6.35	7	8	9	9.52	10	11	12	12.7	-	38.1	66.6	60	3	M4x10	18	25	
40B	6.35	7	8	9	9.52	10	11	12	12.7	-	40	63	60	3	M4x10	18	25	
50A	6.35	7	8	9	9.52	10	11	12	12.7	-	50	60	60	3	M4x10	18	25	
50B	6.35	7	8	9	9.52	10	11	12	12.7	14	50	65	60	3	M5x12	23	30	
50BH	6.35	7	8	9	9.52	10	11	12	12.7	14	50	65	65	3	5.5	25	32	
50C	6.35	7	8	9	9.52	10	11	12	12.7	14	50	70	60	3	M4x10	23	30	
55MH	6.35	7	8	9	9.52	10	11	12	12.7	-	55	80	65	2	5.5	16	23	
60A	6.35	7	8	9	9.52	10	11	12	12.7	-	60	75	65	3	M5x12	18	25	
60A1	6.35	7	8	9	9.52	10	11	12	12.7	14	60	75	65	3	M5x12	23	30	
60B	6.35	7	8	9	9.52	10	11	12	12.7	14	60	85	75	3	M5x12	23	30	
60C	6.35	7	8	9	9.52	10	11	12	12.7	14	60	90	75	3	M5x12	23	30	
70A	6.35	7	8	9	9.52	10	11	12	12.7	14	70	85	75	3	M6x15	23	30	
70B	6.35	7	8	9	9.52	10	11	12	12.7	14	70	90	75	3	M5x12	23	30	
73A	6.35	7	8	9	9.52	10	11	12	12.7	14	73	98.4	85	3	M5x12	25	32	
80A	6.35	7	8	9	9.52	10	11	12	12.7	14	80	100	85	3	M6x15	23	30	

Für weitere Motoradapter und Antriebswellenbohrungen bitte nachfragen.

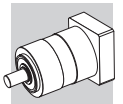

LC 070P

FM

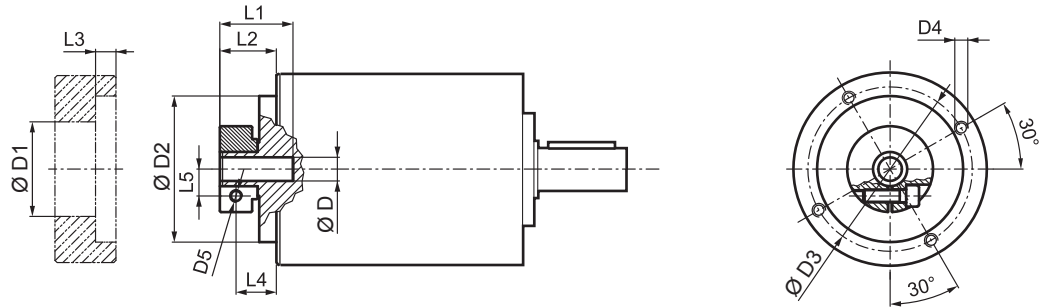

				D1	D2	D3	D4	D5	L1	L2	L3	L4	L5
6.35	7			32.5	50	42.5	M4x8	M4	21.7	13.2	3	8.2	8
8	9	9.52	10	32.5	50	42.5	M4x8	M4	21.7	13.2	3	8.2	9
11	12	12.7		35.5	50	42.5	M4x8	M4	22	13.5	3	8.5	11
14				35.5	50	42.5	M4x8	M4	25	17	3	10.2	11.5

	i	M _{n2}	M _{a2}	M _{p2}	n ₁	n _{1 max}	φ _S	φ _R	C _t	R _{2 max}	A _{2 max}	η	J _G [kgcm ²]	
		[Nm]	[Nm]	[Nm]	[min ⁻¹]	[min ⁻¹]	[arcmin]	[arcmin]	[Nm/arcmin]	[N]	[N]	%		6 ... 9.52
LC 070P 1_3		29	55	60	3300	4000	12'	6'	3	1300	1400	97	0.12	0.14
LC 070P 1_4		30	45	70	3500	5000	12'	6'	3	1300	1400	97	0.08	0.10
LC 070P 1_5		25	40	70	3500	5000	12'	6'	3	1300	1400	97	0.06	0.09
LC 070P 1_7		25	40	70	4000	5000	12'	6'	3	1300	1400	97	0.05	0.07
LC 070P 1_10		18	30	60	4000	6000	12'	6'	3	3500	1400	97	0.04	0.06
LC 070P 2_9		29	55	60	3300	4000	15'	8'	2.5	1300	1400	94	0.11	0.13
LC 070P 2_12		29	55	70	3300	4000	15'	8'	2.5	1300	1400	94	0.10	0.13
LC 070P 2_15		29	55	70	3300	4000	15'	8'	2.5	1300	1400	94	0.10	0.12
LC 070P 2_16		30	45	70	3500	5000	15'	8'	2.5	1300	1400	94	0.07	0.09
LC 070P 2_20		30	45	70	3500	5000	15'	8'	2.5	1300	1400	94	0.06	0.08
LC 070P 2_25		30	45	70	3500	5000	15'	8'	2.5	1300	1400	94	0.06	0.08
LC 070P 2_28		30	45	70	4000	6000	15'	8'	2.5	1300	1400	94	0.05	0.07
LC 070P 2_30		29	55	60	4000	6000	15'	8'	2.5	1300	1400	94	0.04	0.06
LC 070P 2_35		30	45	70	4000	6000	15'	8'	2.5	1300	1400	94	0.05	0.07
LC 070P 2_40		30	45	70	4000	6000	15'	8'	2.5	1300	1400	94	0.04	0.06
LC 070P 2_50		30	45	70	4000	6000	15'	8'	2.5	1300	1400	94	0.04	0.06
LC 070P 2_70		30	45	70	4000	6000	15'	8'	2.5	1300	1400	94	0.04	0.06
LC 070P 2_100		18	30	60	4000	6000	15'	8'	2.5	1300	1400	94	0.04	0.06

LC



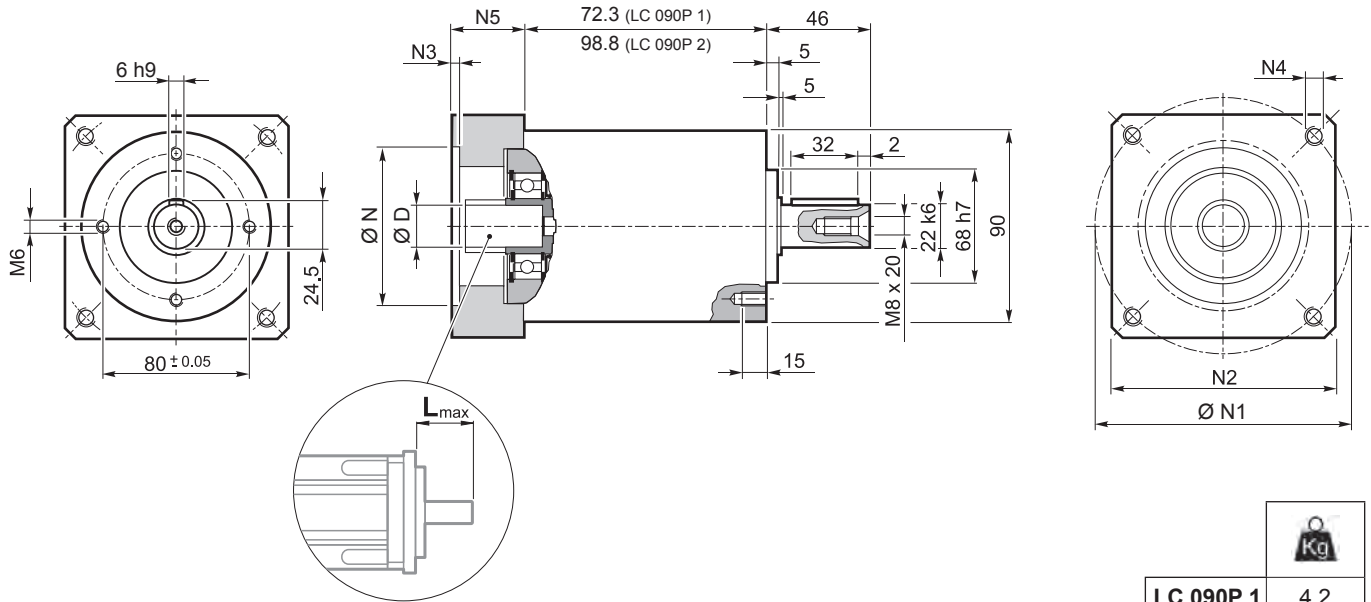

LC 090P

40B1 ... 110B1



	 Kg
LC 090P 1	4.2
LC 090P 2	5.3

												N	N1	N2	N3	N4	N5	L _{max}
40B1	9	9.52	11	12	12.7	14	-	-	-	-	-	40	63	80	4	M4x10	34	40
45A	9	9.52	11	12	12.7	-	-	-	-	-	-	45	63	80	4	M4x10	34	40
50B1	9	9.52	11	12	12.7	14	-	-	-	-	-	50	65	80	4	M5x16	34	40
50BH1	9	9.52	11	12	12.7	14	-	-	-	-	-	50	65	80	4	5.5	34	40
50C1	9	9.52	11	12	12.7	14	-	-	-	-	-	50	70	80	4	M4x10	34	40
50D	9	9.52	11	12	12.7	14	-	-	-	-	-	50	95	80	4	M6x10	34	40
55A	9	9.52	11	12	12.7	14	15.875	16	17	19	19.05	55.5	125.7	105	4	M6x16	34	40
60A2	9	9.52	11	12	12.7	14	-	-	-	-	-	60	75	80	4	M5x16	34	40
60AH2	9	9.52	11	12	12.7	14	-	-	-	-	-	60	75	90	4	5.5	34	40
60B1	9	9.52	11	12	12.7	14	15.875	16	-	-	-	60	85	80	4	M5x16	34	40
60C1	9	9.52	11	12	12.7	14	15.875	16	-	-	-	60	90	80	4	M5x16	34	40
70A1	9	9.52	11	12	12.7	14	15.875	16	17	19	19.05	70	85	80	4	M6x20	34	40
70AH1	9	9.52	11	12	12.7	14	15.875	16	17	19	19.05	70	85	90	4	6.5	34	40
70B1	9	9.52	11	12	12.7	14	15.875	16	17	19	19.05	70	90	80	4	M5x16	34	40
73A1	9	9.52	11	12	12.7	14	-	-	-	-	-	73	98.4	85	4	M5x16	34	40
80A1	9	9.52	11	12	12.7	14	15.875	16	17	19	19.05	80	100	90	4	M6x16	34	40
95A	9	9.52	11	12	12.7	14	15.875	16	17	19	19.05	95	115	100	4	M8x20	34	40
95B	9	9.52	11	12	12.7	14	15.875	16	17	19	19.05	95	130	115	4	M8x20	34	40
110A	9	9.52	11	12	12.7	14	15.875	16	17	19	19.05	110	130	115	4	M8x20	34	40
110B	9	9.52	11	12	12.7	14	15.875	16	17	19	19.05	110	145	120	6.5	M8x20	44	50
110B1	9	9.52	11	12	12.7	14	15.875	16	17	19	19.05	110	145	120	6.5	M8x20	54	60

Für weitere Motoradapter und Antriebswellenbohrungen bitte nachfragen.

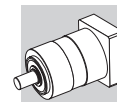

LC 090P

FM

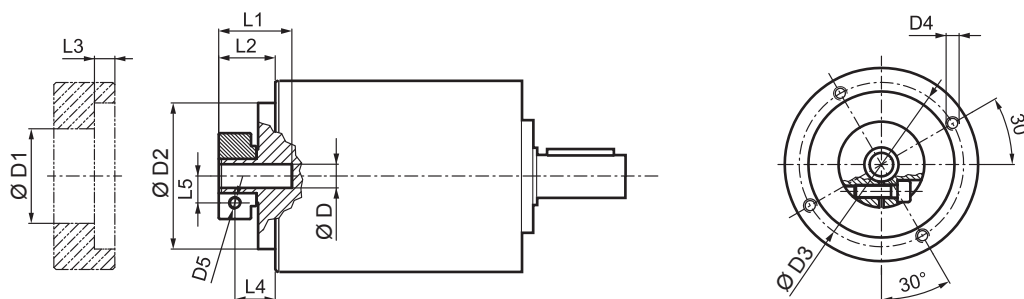

D				D1	D2	D3	D4	D5	L1	L2	L3	L4	L5
9	9.52			38	68	76.5	M6x10	M6	34	26.8	9.5	18.8	10.5
11	12	12.7		43	68	76.5	M6x10	M6	34	26.8	9.5	18.8	12.5
14	15.875	16	17	48	68	76.5	M6x10	M6	34	26.8	9.5	18.8	14.5
19	19.05			51	68	76.5	M6x10	M6	34	26.8	9.5	18.8	16.5

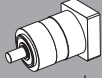
 i	M _{n 2}	M _{a 2}	M _{p 2}	n ₁	n _{1 max}	φ _S	φ _R	C _t	R _{2 max}	A _{2 max}	η	J _G [kgcm ²]	
	[Nm]	[Nm]	[Nm]	[min ⁻¹]	[min ⁻¹]	[arcmin]	[arcmin]	$\frac{Nm}{arcmin}$	[N]	[N]	%	8 ... 12.7	14 ... 19
LC 090P 1_3	65	120	150	3500	4000	12'	6'	12	2200	1900	97	0.62	0.77
LC 090P 1_4	60	110	160	3500	4000	12'	6'	12	2200	1900	97	0.41	0.55
LC 090P 1_5	50	100	160	3200	4500	12'	6'	9	2200	1900	97	0.33	0.47
LC 090P 1_7	50	100	160	4000	6000	12'	6'	9	2200	1900	97	0.26	0.40
LC 090P 1_10	40	70	150	4000	6000	12'	6'	9	2200	1900	97	0.21	0.35
LC 090P 2_9	65	120	150	3500	4000	15'	8'	12	2200	1900	94	0.47	0.61
LC 090P 2_12	65	120	160	3500	4000	15'	8'	12	2200	1900	94	0.44	0.58
LC 090P 2_15	65	120	160	3500	4000	15'	8'	12	2200	1900	94	0.43	0.57
LC 090P 2_16	60	110	160	3500	4500	15'	8'	12	2200	1900	94	0.31	0.45
LC 090P 2_20	60	110	160	3500	4500	15'	8'	12	2200	1900	94	0.26	0.40
LC 090P 2_25	50	100	160	3200	4500	15'	8'	9	2200	1900	94	0.26	0.40
LC 090P 2_28	50	100	160	4000	6000	15'	8'	9	2200	1900	94	0.22	0.36
LC 090P 2_30	65	120	150	4000	6000	15'	8'	12	2200	1900	94	0.20	0.34
LC 090P 2_35	50	100	160	4000	6000	15'	8'	9	2200	1900	94	0.22	0.36
LC 090P 2_40	60	110	160	4000	6000	15'	8'	12	2200	1900	94	0.20	0.34
LC 090P 2_50	50	100	160	4000	6000	15'	8'	9	2200	1900	94	0.20	0.34
LC 090P 2_70	50	100	160	4000	6000	15'	8'	9	2200	1900	94	0.20	0.34
LC 090P 2_100	40	70	150	4000	6000	15'	8'	9	2200	1900	94	0.19	0.34

LC



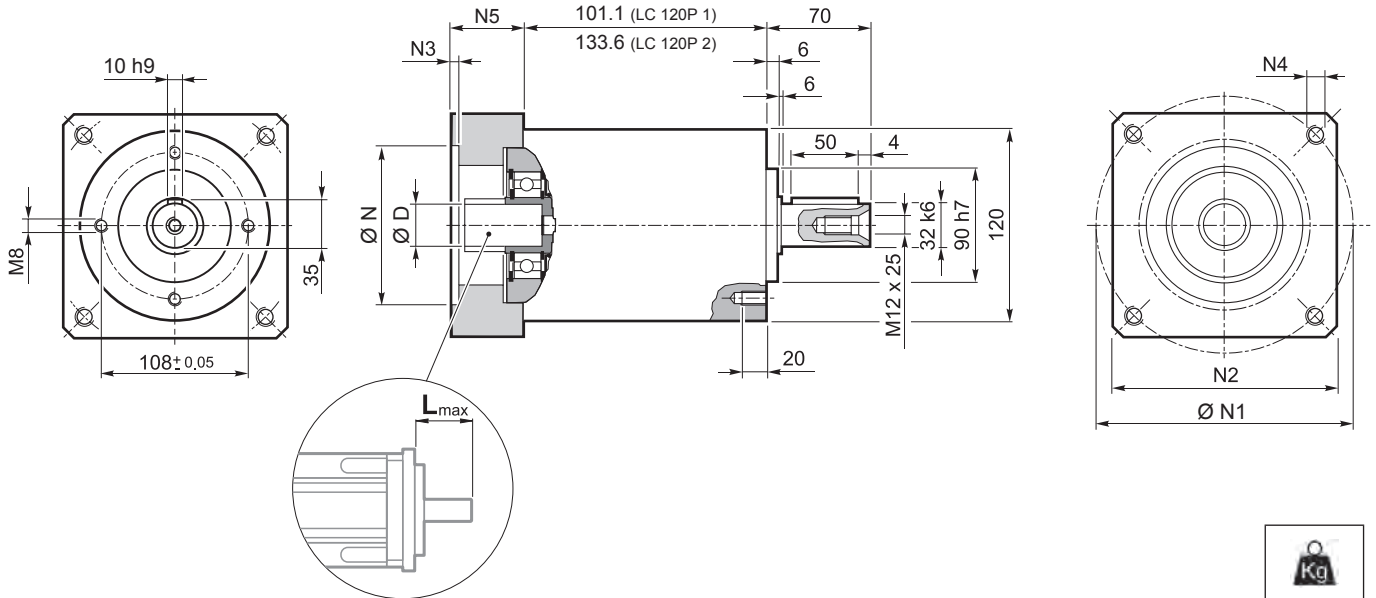

LC 120P

50D ... 130A1



LC 120P 1	9.6
LC 120P 2	12.1

										N	N1	N2	N3	N4	N5	L _{max}
	14	15	15.875	16	19	-	-	-	-							
50D	14	15	15.875	16	19	-	-	-	-	50	95	100	5	M6x14	28	40
55A	14	15	15.875	16	19	-	-	-	-	55.5	125.7	105	5	M6x16	28	40
60A2	14	15	15.875	16	19	-	-	-	-	60	75	100	5	M5x14	28	40
60AH2	14	15	15.875	16	19	-	-	-	-	60	75	100	5	6.5	33	40
60B1	14	15	15.875	16	19	-	-	-	-	60	85	100	6.5	M5x14	28	40
70A1	14	15	15.875	16	19	-	-	-	-	70	85	100	5	M6x14	28	40
70AH1	14	15	15.875	16	19	-	-	-	-	70	85	100	5	6	33	40
70B1	14	15	15.875	16	19	-	-	-	-	70	90	100	5	M5x12	28	40
80A1	14	15	15.875	16	19	-	-	-	-	80	100	100	5	M6x16	28	40
80AH1	14	15	15.875	16	19	-	-	-	-	80	100	100	5	6.5	28	40
95A	14	15	15.875	16	19	-	-	-	-	95	115	100	5	M8x18	28	40
95A1	14	15	15.875	16	19	22	24	-	-	95	115	100	5	M8x18	38	50
95B	14	15	15.875	16	19	-	-	-	-	95	130	115	5	M8x18	28	40
110A	14	15	15.875	16	19	-	-	-	-	110	130	115	5	M8x18	28	40
110A1	14	15	15.875	16	19	22	24	-	-	110	130	115	6.5	M8x20	38	50
110B	14	15	15.875	16	19	22	24	-	-	110	145	120	6.5	M8x20	38	50
110B1	14	15	15.875	16	19	22	24	28	-	110	145	120	6.5	M8x20	48	60
130A	14	15	15.875	16	19	22	24	-	-	130	165	140	6.5	M10x20	38	50
130A1	14	15	15.875	16	19	22	24	28	32	130	165	140	6.5	M10x25	48	60

Für weitere Motoradapter und Antriebswellenbohrungen bitte nachfragen.

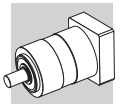

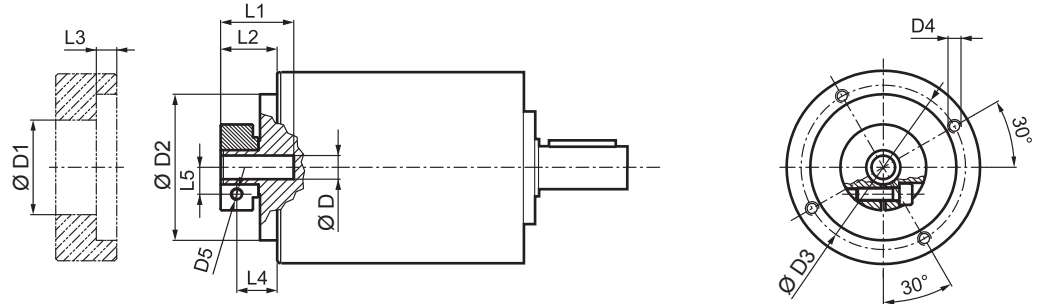

LC 120P

FM

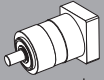

				D1	D2	D3	D4	D5	L1	L2	L3	L4	L5
14	15	15.875	16	48	90	98	M6x15	M6	33.5	20	7.6	12.5	14.5
19				51	90	98	M6x15	M6	33.5	20	7.6	12.5	16.5
22	24			56.5	90	98	M6x15	M6	36.5	23	7.6	14	19
28				67	90	98	M6x15	M8	36.5	23	7.6	14	22.5
32				71	90	98	M6x15	M8	38	24.5	7.6	15.5	24.5

	i	M _{n2} [Nm]	M _{a2} [Nm]	M _{p2} [Nm]	n ₁ [min ⁻¹]	n _{1 max} [min ⁻¹]	φ _S [arcmin]	φ _R [arcmin]	C _t [Nm/arcmin]	R _{2 max} [N]	A _{2 max} [N]	η %	J _G [kgcm ²]		
														14 ... 19	22 ; 24
LC 120P 1_3		155	280	300	3000	4000	12'	6'	30	3500	3000	97	2.17	2.77	3.13
LC 120P 1_4		155	300	360	3000	4500	12'	6'	30	3500	3000	97	1.30	1.89	2.26
LC 120P 1_5		125	240	360	3000	4500	12'	6'	25	3500	3000	97	0.96	1.56	1.92
LC 120P 1_7		125	240	360	3500	4500	12'	6'	25	3500	3000	97	0.66	1.26	1.62
LC 120P 1_10		100	160	300	3500	5000	12'	6'	25	3500	3000	97	0.49	1.09	1.45
LC 120P 2_9		155	280	300	3000	4000	15'	8'	30	3500	3000	94	1.61	2.20	2.57
LC 120P 2_12		155	300	360	3000	4000	15'	8'	30	3500	3000	94	1.51	2.10	2.47
LC 120P 2_15		155	300	360	3000	4000	15'	8'	30	3500	3000	94	1.47	2.06	2.43
LC 120P 2_16		155	300	360	3000	4500	15'	8'	30	3500	3000	94	0.92	1.52	1.88
LC 120P 2_20		155	300	360	3000	4500	15'	8'	30	3500	3000	94	0.90	1.50	1.86
LC 120P 2_25		125	240	360	3000	4500	15'	8'	22.5	3500	3000	94	0.71	1.30	1.67
LC 120P 2_28		125	240	360	3500	5000	15'	8'	22.5	3500	3000	94	0.54	1.13	1.50
LC 120P 2_30		155	300	300	3500	5000	15'	8'	30	3500	3000	94	0.44	1.04	1.40
LC 120P 2_35		125	240	360	3500	5000	15'	8'	22.5	3500	3000	94	0.53	1.13	1.49
LC 120P 2_40		155	300	360	3500	5000	15'	8'	30	3500	3000	94	0.43	1.03	1.39
LC 120P 2_50		125	240	360	3500	5000	15'	8'	22.5	3500	3000	94	0.43	1.02	1.39
LC 120P 2_70		125	240	360	3500	5000	15'	8'	22.5	3500	3000	94	0.42	1.02	1.38
LC 120P 2_100		100	160	300	3500	5000	15'	8'	22.5	3500	3000	94	0.42	1.02	1.38

LC



LC 155P

55A1 ... 180A1

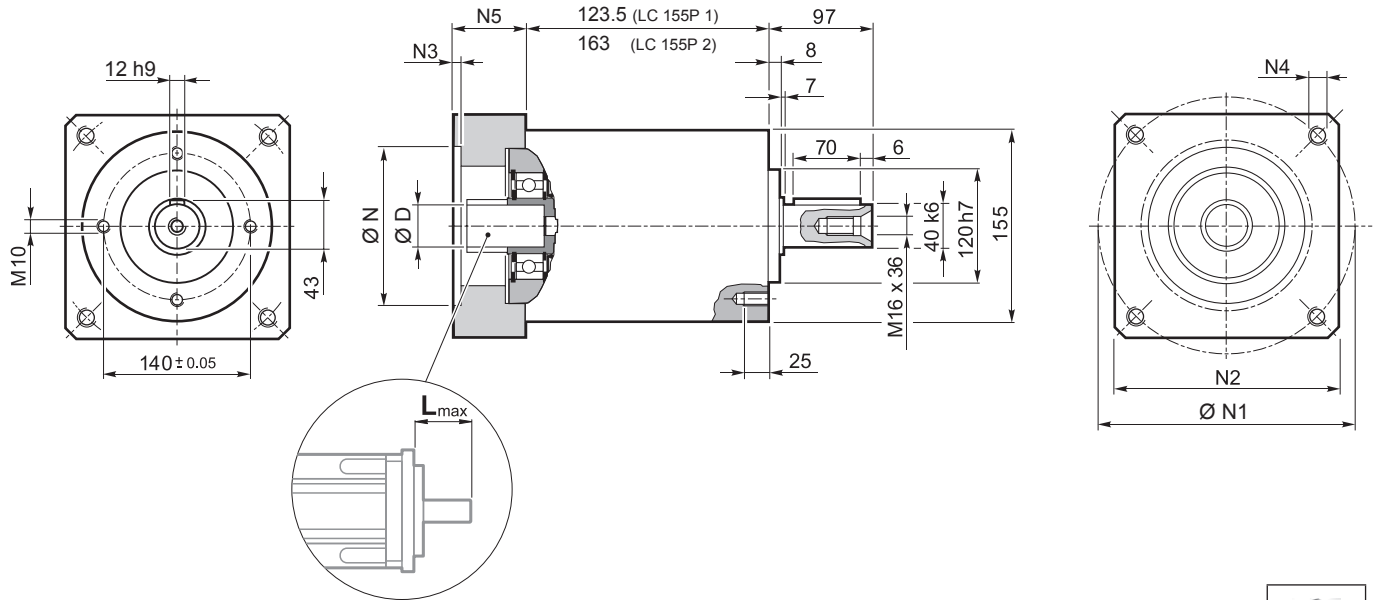

LC 155P 1	19.3
LC 155P 2	24.3

LC

								N	N1	N2	N3	N4	N5	L _{max}	
	55A1	19	-	-	-	-	-	55.5	125.7	130	4	M6x15	39.5	50	
	80A2	19	-	-	-	-	-	80	100	130	4	M6x15	39.5	50	
	95A1	19	22	24	-	-	-	95	115	130	4	M8x20	39.5	50	
	110A1	19	22	24	-	-	-	110	130	130	4	M8x20	39.5	50	
	110B1	19	22	24	-	-	-	110	145	130	6.5	M8x20	49.5	60	
	114A	19	22	24	28	32	35	38	114.3	200	170	5.5	M12x25	69.5	80
	130A	19	22	24	-	-	-	-	130	165	140	4	M10x20	39.5	50
	130A1	19	22	24	28	32	-	-	130	165	140	4	M10x20	49.5	60
	180A	19	22	24	28	32	-	-	180	215	190	5.5	M14x25	49.5	60
	180A1	19	22	24	28	32	35	38	180	215	190	5.5	M14x25	69.5	80

Für weitere Motoradapter und Antriebswellenbohrungen bitte nachfragen.

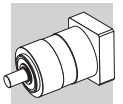

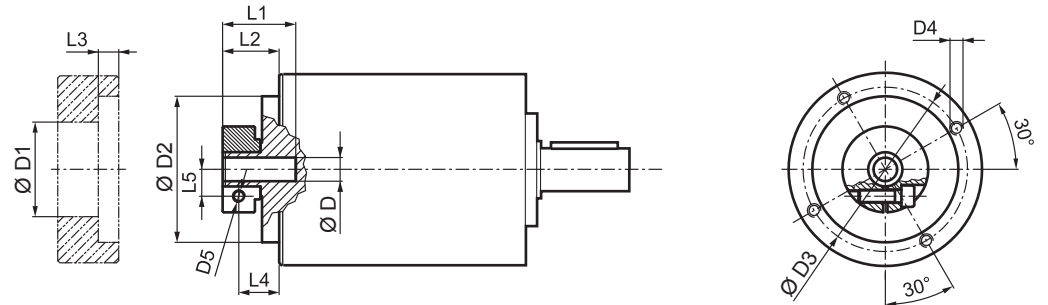

LC 155P

FM

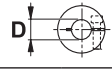

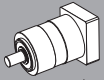
	D1	D2	D3	D4	D5	L1	L2	L3	L4	L5
19	51	113	125.5	M8x15	M6	40	27.5	6	20	16.5
22 24	56.5	113	125.5	M8x15	M6	41	28.5	6	19.5	19
28	67	113	125.5	M8x15	M8	41	28.5	6	19.5	22.5
32	71	113	125.5	M8x15	M8	41	28.5	6	18.5	24.5
35	73	113	125.5	M8x15	M8	50	37.5	11.25	26	26
38	77.5	113	125.5	M8x15	M8	50	37.5	11.25	26	28

	i	M _{n 2} [Nm]	M _{a 2} [Nm]	M _{p 2} [Nm]	n ₁ [min ⁻¹]	n _{1 max} [min ⁻¹]	φ _S [arcmin]	φ _R [arcmin]	C _t [$\frac{Nm}{arcmin}$]	R _{2 max} [N]	A _{2 max} [N]	η %	J _G [kgcm ²]			
														19	22 ; 24	28 ; 32
LC 155P 1_3		250	380	600	2100	3600	12'	6'	50	6000	5000	97	7.99	8.19	8.54	9.90
LC 155P 1_4		350	500	1000	2400	3600	12'	6'	50	6000	5000	97	4.66	4.87	5.23	6.57
LC 155P 1_5		350	500	1000	2900	3600	12'	6'	50	6000	5000	97	3.32	2.53	3.53	5.23
LC 155P 1_7		350	500	1000	3200	3600	12'	6'	50	6000	5000	97	2.14	2.35	2.70	4.05
LC 155P 1_10		230	350	750	3200	3600	12'	6'	50	6000	5000	97	1.14	1.66	2.01	3.36
LC 155P 2_9		250	380	600	2100	3600	15'	8'	48	6000	5000	94	5.30	5.51	5.86	7.21
LC 155P 2_12		450	700	1000	2100	3600	15'	8'	48	6000	5000	94	4.93	5.14	5.49	6.84
LC 155P 2_15		450	700	1000	2100	3600	15'	8'	48	6000	5000	94	4.79	4.99	5.34	6.70
LC 155P 2_16		450	700	1000	2400	3600	15'	8'	48	6000	5000	94	2.97	3.18	3.53	4.88
LC 155P 2_20		450	700	1000	2900	3600	15'	8'	48	6000	5000	94	2.23	2.44	2.79	4.14
LC 155P 2_25		450	700	1000	2900	3600	15'	8'	48	6000	5000	94	2.18	2.39	2.74	4.09
LC 155P 2_28		450	700	1000	3200	3600	15'	8'	48	6000	5000	94	1.58	1.79	2.14	3.49
LC 155P 2_30		250	380	750	3200	3600	15'	8'	48	6000	5000	94	1.23	1.44	1.79	3.14
LC 155P 2_35		450	700	1000	3200	3600	15'	8'	48	6000	5000	94	1.55	1.76	2.11	3.46
LC 155P 2_40		450	700	1000	3200	3600	15'	8'	48	6000	5000	94	1.20	1.41	1.76	3.11
LC 155P 2_50		450	700	1000	3200	3600	15'	8'	48	6000	5000	94	1.19	1.39	1.74	3.10
LC 155P 2_70		450	700	1000	3200	3600	15'	8'	48	6000	5000	94	1.17	1.38	1.73	3.08
LC 155P 2_100		230	350	750	3200	3600	15'	8'	48	6000	5000	94	1.17	1.38	1.73	3.08

LC

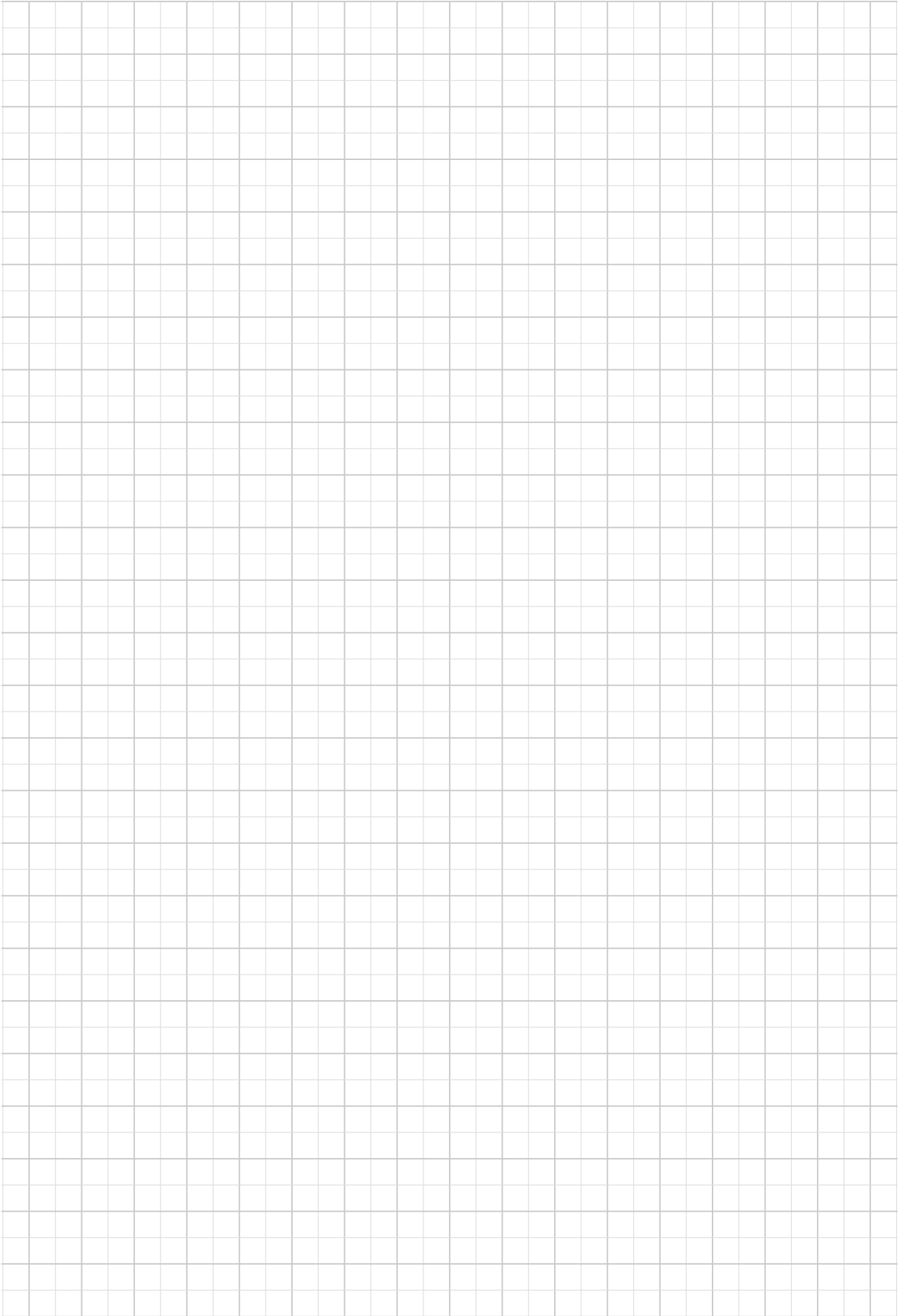
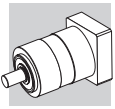

LC

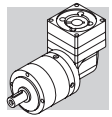

LCK

ABGEWINKELTES PRÄZISIONSPLANETENGETRIEBE

Die LCK-Reihe bietet in Winkelbauform die gleichen Merkmale der LC-Reihe. Die Winkelbauweise erleichtert dabei die Installation an Stellen, an denen der Platz beschränkt ist.

Diese Getriebe sind dank optimaler Leistungsfähigkeit und Zuverlässigkeit eine flexible Lösung und wirtschaftliche Alternative.

Verbesserte Leistungsfähigkeit als Schlüssel zum Downsizing.

Die verbesserte Leistungsfähigkeit unseres LC-Präzisionsgetriebes (neue Option "P") kann wichtige Downsizing-Optionen für zahlreiche Anwendungen eröffnen, bei denen es zuvor nicht möglich war, ein höheres übertragbares Abtriebsdrehmoment bereitzustellen.

Ein weiterer Vorteil des Downsizing ist eine verbesserte Energieeffizienz, indem man ein kompakteres Getriebe mit höherer Drehmomentdichte wählen und dadurch die Beschleunigungsmasse deutlich reduzieren kann. Das übertragbare Drehmoment wurde um bis zu 40% verbessert.

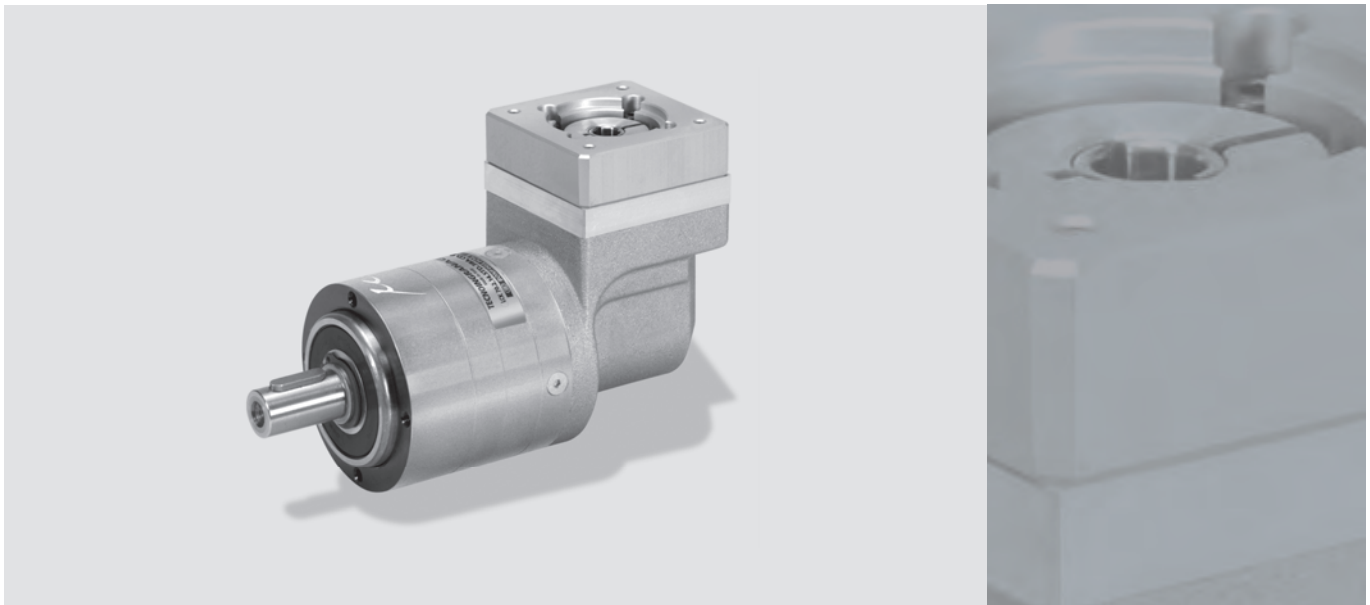

LCK

Produktmerkmale:

- Option "P" mit hoher Drehmomentdichte für eine größere Produktleistungsfähigkeit verfügbar
- Optimales Beschleunigungs- und Nenndrehmoment
- Optimale radiale und axiale Belastbarkeit
- Entwickelt für Zyklus- und Dauerbetrieb
- Optimale Verdrehsteifigkeit
- Verdrehflankenspiel – unter 6 arcmin
- Einsetzbar in beliebiger Montageposition

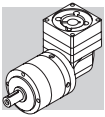

8 MERKMALE DER LCK-REIHE

Die LCK-Reihe bietet in Winkelbauform die gleichen Merkmale der LC-Reihe, sowie den zusätzlichen Vorteil einer einfacheren Installation bei eingeschränkten Platzverhältnissen.

- Erhältlich mit standard Flankenspiel:
2-stufige Getriebe: standard $\varphi_S \leq 6'$;
3-stufige Getriebe: standard $\varphi_S \leq 8'$;
- Eine hohe IP-Schutzklasse (IP64) sorgt dafür, dass innenliegende Teile vor Staub- und Flüssigkeitseintritt geschützt sind.
- Serienmäßige Fluorelastomer-Wellendichtungen an der Eingangswelle
- Schalldruckpegel $L_P \leq 70$ dB(A). Gemessen in 1 m Abstand ohne Last und bei einer Eingangsrehzahl von $n_1 = 3000 \text{ min}^{-1}$; $i=10$.
- Große Auswahl an Motoradaptern sorgt für den Anschluss an die marktgängigsten Servomotoren.
- Die Getriebe sind werksseitig mit synthetischem Schmierfett gemäß NLGI-Konsistenzklasse 00 gefüllt; ohne Verunreinigung muss das Schmiermittel nicht regelmäßig gewechselt werden.
- Umgebungstemperatur min. -20°C , max. $+30^\circ\text{C}$; bei Temperaturen höher als 30°C ist der Temperaturfaktor f_T zu berücksichtigen.
- Die Gehäusetemperatur darf $T_{\text{max}} = 90^\circ\text{C}$ nicht übersteigen.
- Erhältlich als Version P mit höherem Abtriebsdrehmoment.

Übersicht der Nenndrehmomente M_{n2} [Nm]												
[i]	6	8	10	14	20	24	30	50	70	80	90	100
LCK 050	10	12	12	12	-	12	12	12	12	-	12	-
LCK 070	18	25	25	25	18	25	25	25	25	25	-	25
LCK 070P	25	30	25	25	18	29	29	30	30	30	-	30
LCK 090	37	43	43	43	37	43	43	43	43	43	-	43
LCK 090P	45	60	50	50	40	60	60	50	50	60	-	50
LCK 120	95	110	110	110	95	110	110	110	110	110	-	110
LCK 120P	110	140	125	125	100	155	155	125	125	155	-	125
LCK 155	250	300	300	300	230	300	300	300	300	300	-	300
LCK 155P	250	350	350	350	230	450	450	450	450	450	-	450

LCK

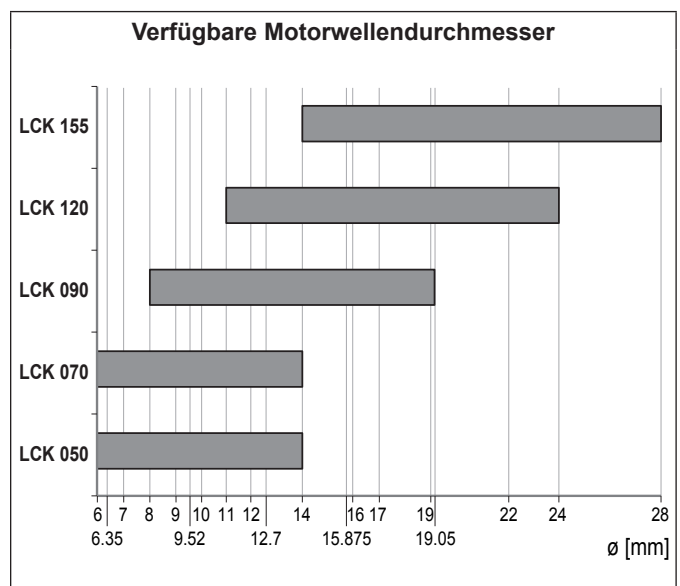
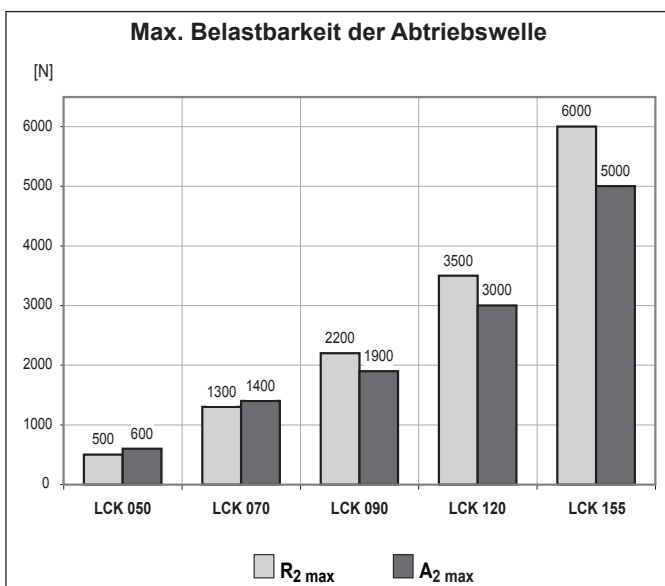

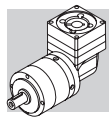

8.1 BESTELLBEZEICHNUNG

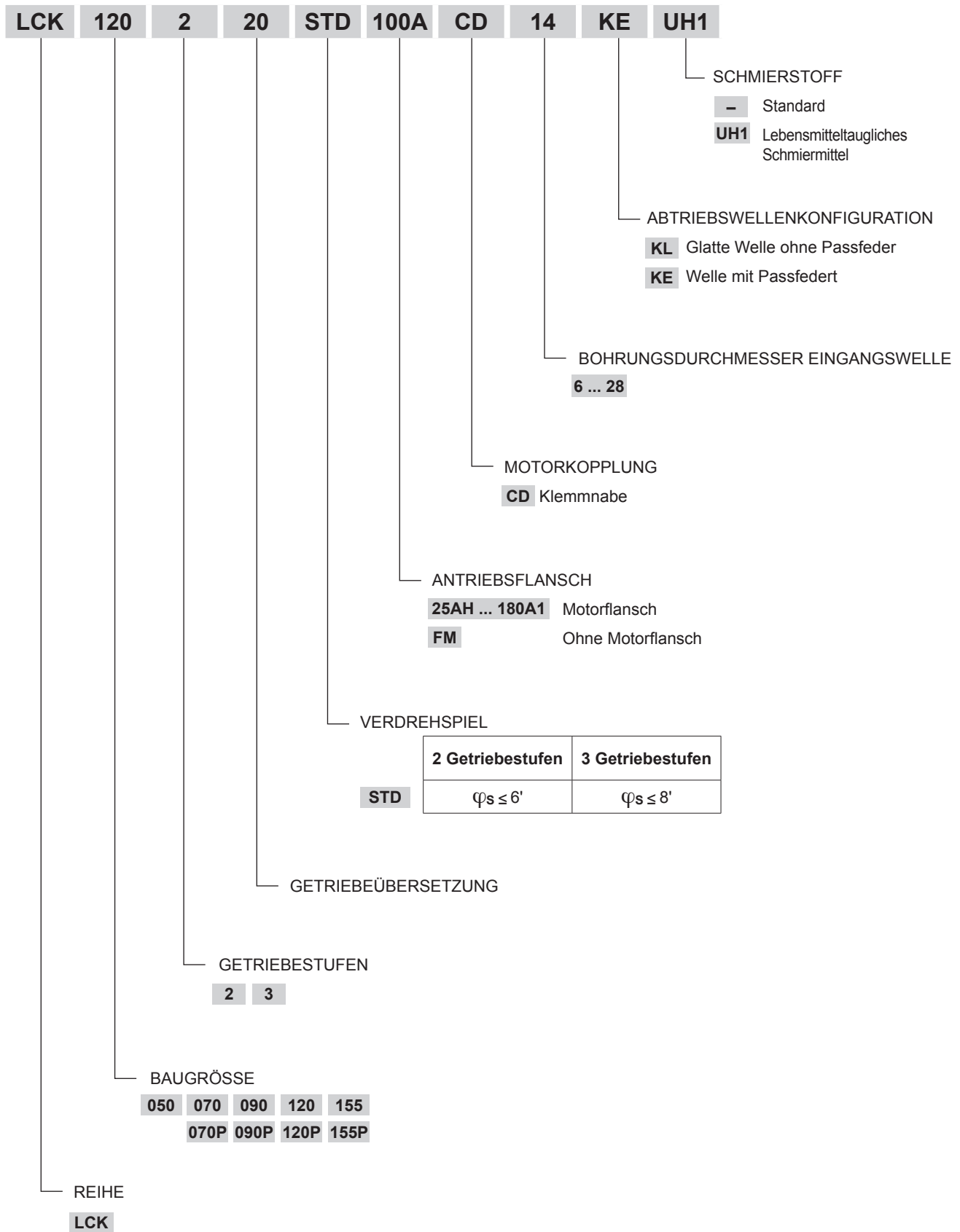

LCK

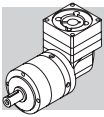

ABMESSUNGEN UND TECHNISCHE DATEN

LCK 050

25AH ... 80A

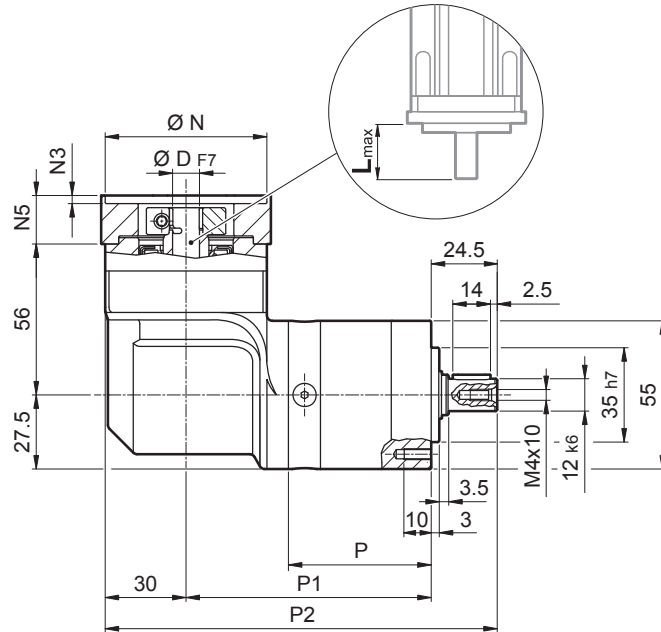
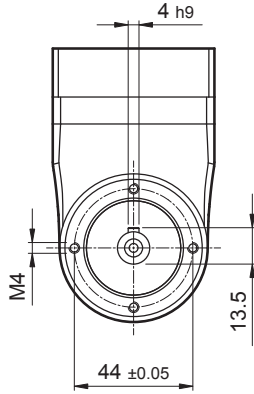

	P	P1	P2	kg
LCK 050 2	53	91	145.5	1.6
LCK 050 3	66.8	104.8	159.3	1.8

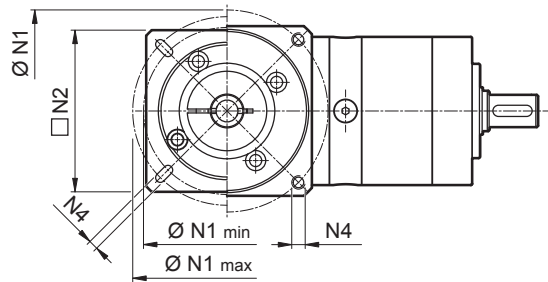

	D														N	N1		N2	N3	N4	N5	L _{max}	
	6	6.35	7	8	9	9.52	-	-	-	-	-	-	-	-		min	max						
25AH	6	6.35	7	8	9	9.52	-	-	-	-	-	-	-	25	39	56							
26AH	6	6.35	7	8	9	9.52	-	-	-	-	-	-	-	26	39	56							
28AH	6	6.35	7	8	9	9.52	-	-	-	-	-	-	-	28	39	56							
30AH	6	6.35	7	8	9	9.52	-	-	-	-	-	-	-	30	39	56							
32AH	6	6.35	7	8	9	9.52	-	-	-	-	-	-	-	32	39	56	65	3.5	4.5	25	25		
34AH	6	6.35	7	8	9	9.52	-	-	-	-	-	-	-	34	40	56							
36AH	6	6.35	7	8	9	9.52	-	-	-	-	-	-	-	36	42	56							
38AH	6	6.35	7	8	9	9.52	-	-	-	-	-	-	-	39	45	56							
40AH	6	6.35	7	8	9	9.52	-	-	-	-	-	-	-	40	46	56							
38B	6	6.35	7	8	9	9.52	10	11	12	12.7	-	-	-	38.1	66.6	60	3	M4x10	18	25			
40B	6	6.35	7	8	9	9.52	10	11	12	12.7	-	-	-	40	63	60	3	M4x10	18	25			
50A	6	6.35	7	8	9	9.52	10	11	12	12.7	-	-	-	50	60	60	3	M4x10	18	25			
50B	6	6.35	7	8	9	9.52	10	11	12	12.7	14	-	-	50	65	60	3	M5x12	23	30			
50BH	6	6.35	7	8	9	9.52	10	11	12	12.7	14	-	-	50	65	65	3	5.5	25	32			
50C	6	6.35	7	8	9	9.52	10	11	12	12.7	14	-	-	50	70	60	3	M4x10	23	30			
50MH	6	6.35	7	8	9	9.52	10	11	12	12.7	-	-	-	55	80	65	2	5.5	16	23			
60A	6	6.35	7	8	9	9.52	10	11	12	12.7	-	-	-	60	75	65	3	M5x12	18	25			
60A1	6	6.35	7	8	9	9.52	10	11	12	12.7	14	-	-	60	75	65	3	M5x12	23	30			
60B	6	6.35	7	8	9	9.52	10	11	12	12.7	14	-	-	60	85	75	3	M5x12	23	30			
60C	6	6.35	7	8	9	9.52	10	11	12	12.7	14	-	-	60	90	75	3	M5x12	23	30			
70A	6	6.35	7	8	9	9.52	10	11	12	12.7	14	-	-	70	85	75	3	M6x15	23	30			
70B	6	6.35	7	8	9	9.52	10	11	12	12.7	14	-	-	70	90	75	3	M5x12	23	30			
73A	6	6.35	7	8	9	9.52	10	11	12	12.7	14	-	-	73	98.4	85	3	M5x12	25	32			
80A	6	6.35	7	8	9	9.52	10	11	12	12.7	14	-	-	80	100	85	3	M6x15	23	30			

LCK

Für weitere Motoradapter und Antriebswellenbohrungen bitte nachfragen.

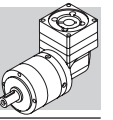

LCK 050

FM

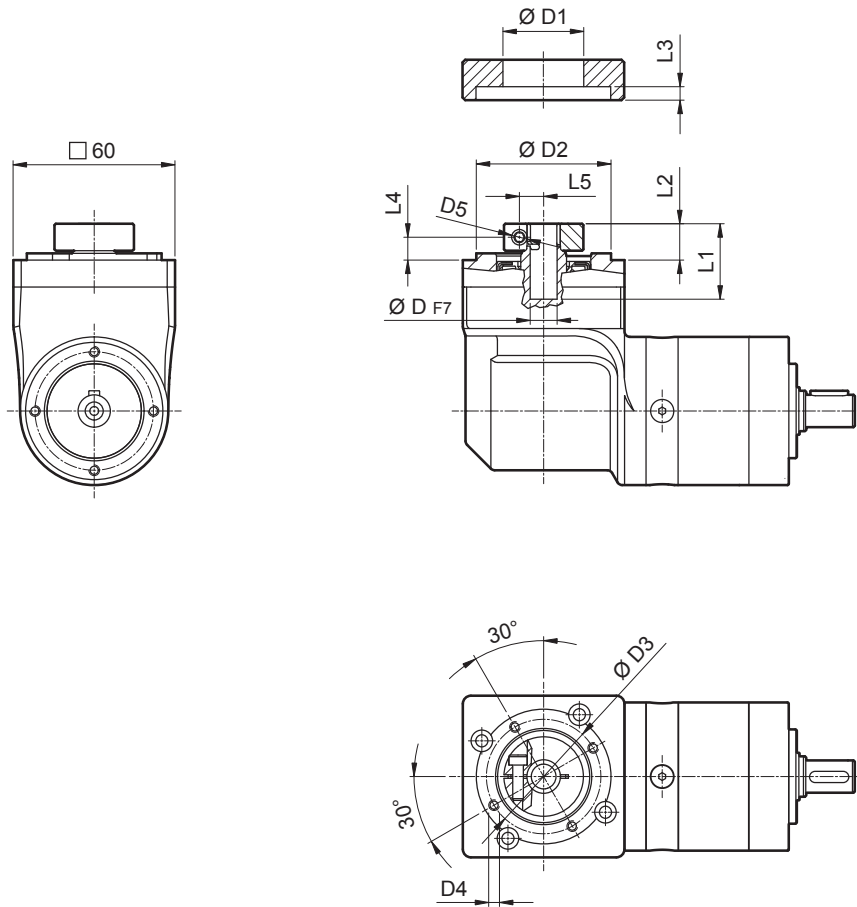

D		D1	D2	D3	D4	D5	L1	L2	L3	L4	L5
6	6.35 7	32.5	50	42.5	M4x8	M4	28	13.5	3	8.5	8
8	9 9.52 10	32.5	50	42.5	M4x8	M4	28	13.5	3	8.5	9
11	12 12.7	35.5	50	42.5	M4x8	M4	23	13.5	3	8.5	11
14		35.5	50	42.5	M4x8	M4	25	15.5	3	8.9	11.5

 i	M_{n2}	M_{a2}	M_{p2}	n_1	$n_{1\max}$	φ_s	C_t	$R_{2\max}$	$A_{2\max}$	η	J_G [kgcm ²]	
	[Nm]	[Nm]	[Nm]	[min ⁻¹]	[min ⁻¹]	[arcmin]	$\left[\frac{Nm}{arcmin} \right]$	[N]	[N]	%	6 ... 9.52	10 ... 14
LCK 050 2_6	10	16	28	2500	5000	6'	0.9	500	600	94	0.23	0.25
LCK 050 2_8	12	20	30	2500	5000	6'	0.9	500	600	94	0.23	0.24
LCK 050 2_10	12	20	30	2500	5000	6'	0.9	500	600	94	0.23	0.24
LCK 050 2_14	12	20	30	2500	5000	6'	0.9	500	600	94	0.23	0.24
LCK 050 3_24	12	20	30	2500	5000	8'	0.7	500	600	91	0.23	0.25
LCK 050 3_30	12	20	30	2500	5000	8'	0.7	500	600	91	0.23	0.25
LCK 050 3_50	12	20	30	2500	5000	8'	0.7	500	600	91	0.23	0.24
LCK 050 3_70	12	20	30	2500	5000	8'	0.7	500	600	91	0.23	0.24
LCK 050 3_90	12	20	30	2500	5000	8'	0.7	500	600	91	0.22	0.24

LCK

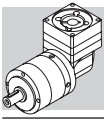

LCK 070

25AH ... 80A

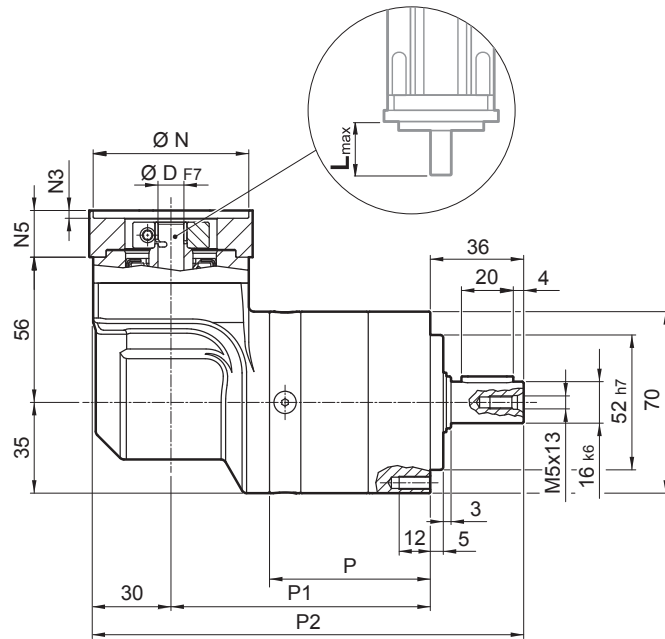
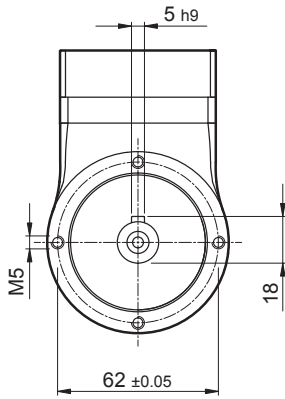

	P	P1	P2	kg
LCK 070 2	62	100	166	2.7
LCK 070 3	78.7	116.7	182.7	3.0

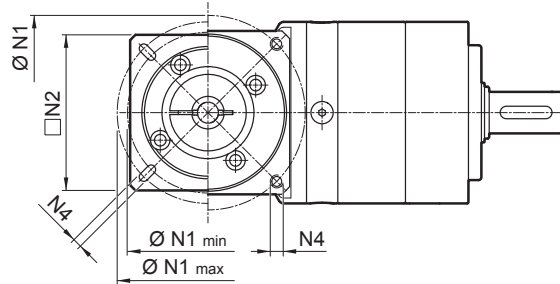

	D														N	N1		N2	N3	N4	N5	L _{max}	
	6	6.35	7	8	9	9.52	-	-	-	-	-	-	-	-		min	max						
25AH	6	6.35	7	8	9	9.52	-	-	-	-	-	-	-	25	39	56							
26AH	6	6.35	7	8	9	9.52	-	-	-	-	-	-	-	26	39	56							
28AH	6	6.35	7	8	9	9.52	-	-	-	-	-	-	-	28	39	56							
30AH	6	6.35	7	8	9	9.52	-	-	-	-	-	-	-	30	39	56							
32AH	6	6.35	7	8	9	9.52	-	-	-	-	-	-	-	32	39	56	65	3.5	4.5	25	25		
34AH	6	6.35	7	8	9	9.52	-	-	-	-	-	-	-	34	40	56							
36AH	6	6.35	7	8	9	9.52	-	-	-	-	-	-	-	36	42	56							
39AH	6	6.35	7	8	9	9.52	-	-	-	-	-	-	-	39	45	56							
40AH	6	6.35	7	8	9	9.52	-	-	-	-	-	-	-	40	46	56							
38B	6	6.35	7	8	9	9.52	10	11	12	12.7	-	-	-	38.1	66.6	60	3	M4x10	18	25			
40B	6	6.35	7	8	9	9.52	10	11	12	12.7	-	-	-	40	63	60	3	M4x10	18	25			
50A	6	6.35	7	8	9	9.52	10	11	12	12.7	-	-	-	50	60	60	3	M4x10	18	25			
50B	6	6.35	7	8	9	9.52	10	11	12	12.7	14	-	-	50	65	60	3	M5x12	23	30			
50BH	6	6.35	7	8	9	9.52	10	11	12	12.7	14	-	-	50	65	65	3	5.5	25	32			
50C	6	6.35	7	8	9	9.52	10	11	12	12.7	14	-	-	50	70	60	3	M4x10	23	30			
55MH	6	6.35	7	8	9	9.52	10	11	12	12.7	-	-	-	55	80	65	2	5.5	16	23			
60A	6	6.35	7	8	9	9.52	10	11	12	12.7	-	-	-	60	75	65	3	M5x12	18	25			
60A1	6	6.35	7	8	9	9.52	10	11	12	12.7	14	-	-	60	75	65	3	M5x12	23	30			
60B	6	6.35	7	8	9	9.52	10	11	12	12.7	14	-	-	60	85	75	3	M5x12	23	30			
60C	6	6.35	7	8	9	9.52	10	11	12	12.7	14	-	-	60	90	75	3	M5x12	23	30			
70A	6	6.35	7	8	9	9.52	10	11	12	12.7	14	-	-	70	85	75	3	M6x15	23	30			
70B	6	6.35	7	8	9	9.52	10	11	12	12.7	14	-	-	70	90	75	3	M5x12	23	30			
73A	6	6.35	7	8	9	9.52	10	11	12	12.7	14	-	-	73	98.4	85	3	M5x12	25	32			
80A	6	6.35	7	8	9	9.52	10	11	12	12.7	14	-	-	80	100	85	3	M6x15	23	30			

Für weitere Motoradapter und Antriebswellenbohrungen bitte nachfragen.

LCK

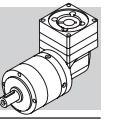

LCK 070

FM

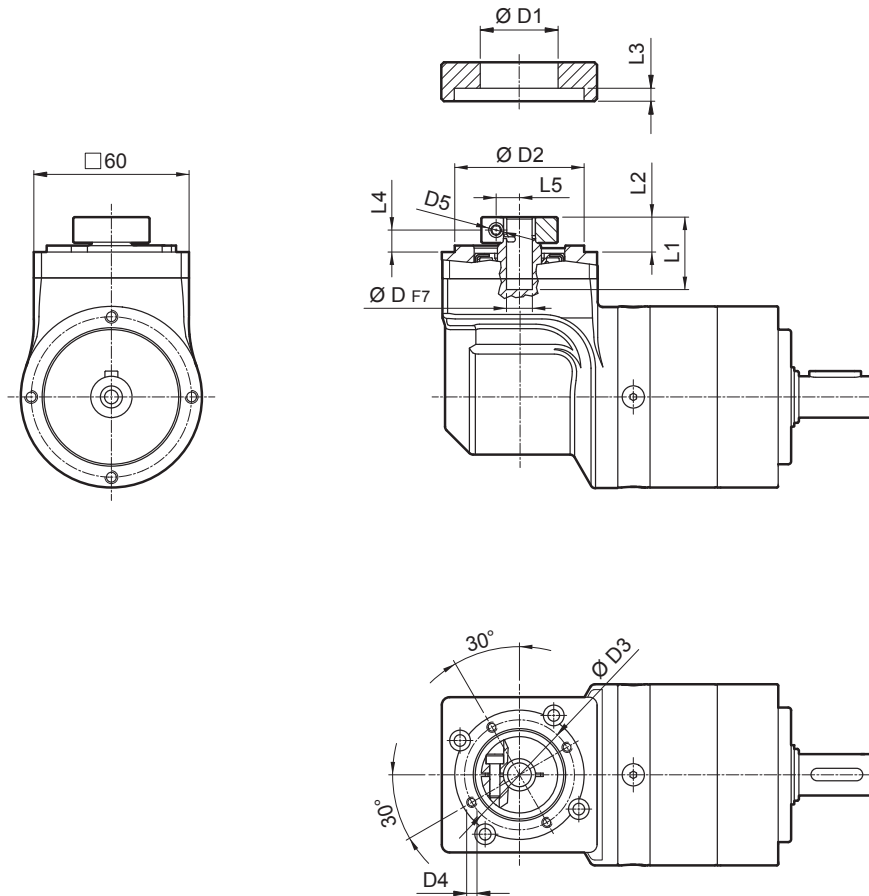

D		D1	D2	D3	D4	D5	L1	L2	L3	L4	L5
6	6.35 7	32.5	50	42.5	M4x8	M4	28	13.5	3	8.5	8
8	9 9.52 10	32.5	50	42.5	M4x8	M4	28	13.5	3	8.5	9
11	12 12.7	35.5	50	42.5	M4x8	M4	23	13.5	3	8.5	11
14		35.5	50	42.5	M4x8	M4	25	15.5	3	8.9	11.5

 i	M _{n2}	M _{a2}	M _{p2}	n ₁	n _{1 max}	φ _s	C _t	R _{2 max}	A _{2 max}	η	J _G [kgcm ²]	
	[Nm]	[Nm]	[Nm]	[min ⁻¹]	[min ⁻¹]	[arcmin]	$\frac{Nm}{arcmin}$	[N]	[N]	%	6 ... 9.52	10 ... 14
LCK 070 2_6	18	30	45	2500	5000	6'	2.8	1300	1400	94	0.25	0.26
LCK 070 2_8	25	35	60	2500	5000	6'	2.8	1300	1400	94	0.24	0.25
LCK 070 2_10	25	35	70	2500	5000	6'	2.8	1300	1400	94	0.23	0.25
LCK 070 2_14	25	35	70	2500	5000	6'	2.8	1300	1400	94	0.23	0.24
LCK 070 2_20	18	30	60	2500	5000	6'	2.8	1300	1400	94	0.23	0.24
LCK 070 3_24	25	35	70	2500	5000	8'	2.5	1300	1400	91	0.24	0.26
LCK 070 3_30	25	35	70	2500	5000	8'	2.5	1300	1400	91	0.24	0.26
LCK 070 3_50	25	35	70	2500	5000	8'	2.5	1300	1400	91	0.23	0.24
LCK 070 3_70	25	35	70	2500	5000	8'	2.5	1300	1400	91	0.23	0.24
LCK 070 3_80	25	35	70	2500	5000	8'	2.5	1300	1400	91	0.23	0.24
LCK 070 3_100	25	35	70	2500	5000	8'	2.5	1300	1400	91	0.23	0.24

LCK

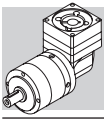

LCK 090

40B1 ... 110B1

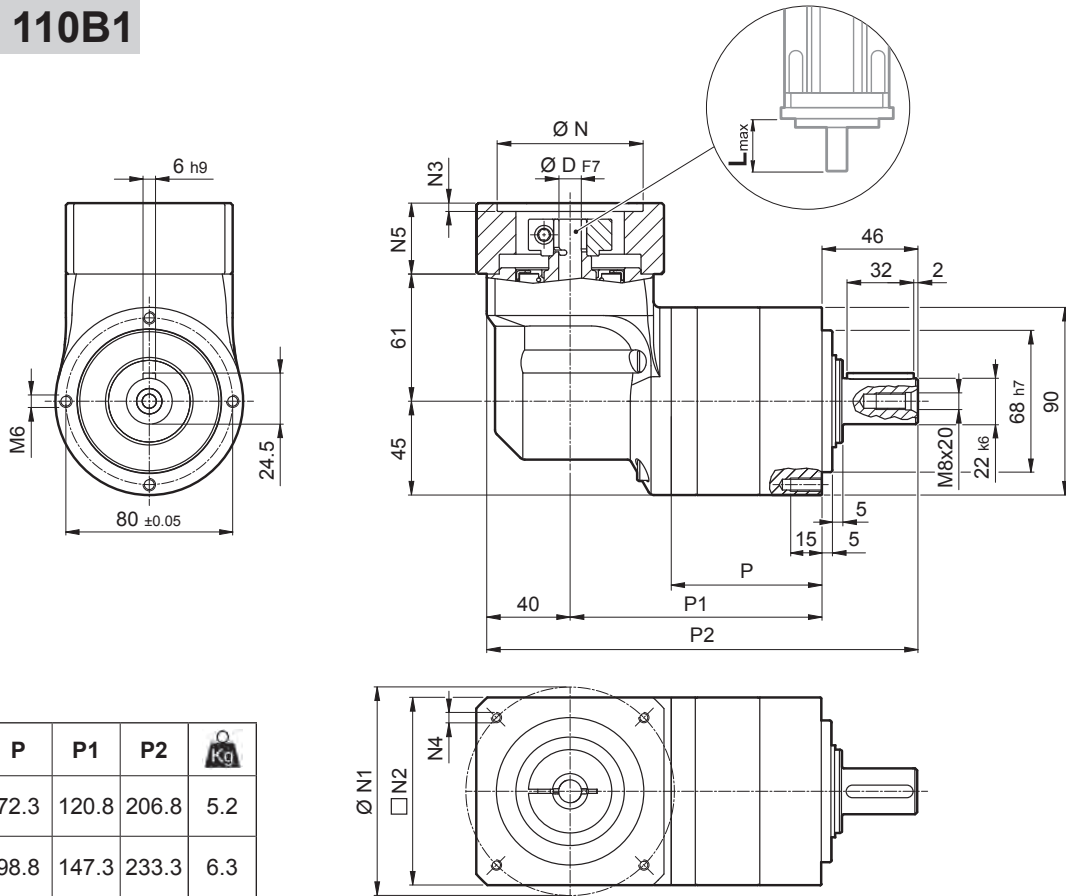

	P	P1	P2	Kg
LCK 090 2	72.3	120.8	206.8	5.2
LCK 090 3	98.8	147.3	233.3	6.3

LCK

											N	N1	N2	N3	N4	N5	L _{max}		
40B1	8	9	9.52	11	12	12.7	14	-	-	-	-	40	63	80	4	M4x10	34	40	
45A	8	9	9.52	11	12	12.7	-	-	-	-	-	45	63	80	4	M4x10	34	40	
50B1	8	9	9.52	11	12	12.7	14	-	-	-	-	50	65	80	4	M5x16	34	40	
50BH1	8	9	9.52	11	12	12.7	14	-	-	-	-	50	65	80	4	5.5	34	40	
50C1	8	9	9.52	11	12	12.7	14	-	-	-	-	50	70	80	4	M4x10	34	40	
50D	8	9	9.52	11	12	12.7	14	-	-	-	-	50	95	80	4	M6x10	34	40	
55A	8	9	9.52	11	12	12.7	14	15.875	16	17	19	19.05	55.5	125.7	105	4	M6x16	34	40
60A2	8	9	9.52	11	12	12.7	14	-	-	-	-	60	75	80	4	M5x16	34	40	
60AH2	8	9	9.52	11	12	12.7	14	-	-	-	-	60	75	90	4	5.5	34	40	
60B1	8	9	9.52	11	12	12.7	14	15.875	16	-	-	60	85	80	4	M5x16	34	40	
60C1	8	9	9.52	11	12	12.7	14	15.875	16	-	-	60	90	80	4	M5x16	34	40	
70A1	8	9	9.52	11	12	12.7	14	15.875	16	17	19	19.05	70	85	80	4	M6x20	34	40
70AH1	8	9	9.52	11	12	12.7	14	15.875	16	17	19	19.05	70	85	90	4	6.5	34	40
70B1	8	9	9.52	11	12	12.7	14	15.875	16	17	19	19.05	70	90	80	4	M5x16	34	40
73A1	8	9	9.52	11	12	12.7	14	-	-	-	-	73	98.4	85	4	M5x16	34	40	
80A1	8	9	9.52	11	12	12.7	14	15.875	16	17	19	19.05	80	100	90	4	M6x16	34	40
95A	8	9	9.52	11	12	12.7	14	15.875	16	17	19	19.05	95	115	100	4	M8x20	34	40
95B	8	9	9.52	11	12	12.7	14	15.875	16	17	19	19.05	95	130	115	4	M8x20	34	40
110A	8	9	9.52	11	12	12.7	14	15.875	16	17	19	19.05	110	130	115	4	M8x20	34	40
110B	8	9	9.52	11	12	12.7	14	15.875	16	17	19	19.05	110	145	120	6.5	M8x20	44	50
110B1	8	9	9.52	11	12	12.7	14	15.875	16	17	19	19.05	110	145	120	6.5	M8x20	54	60

Für weitere Motoradapter und Antriebswellenbohrungen bitte nachfragen.

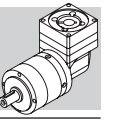

LCK 090

FM

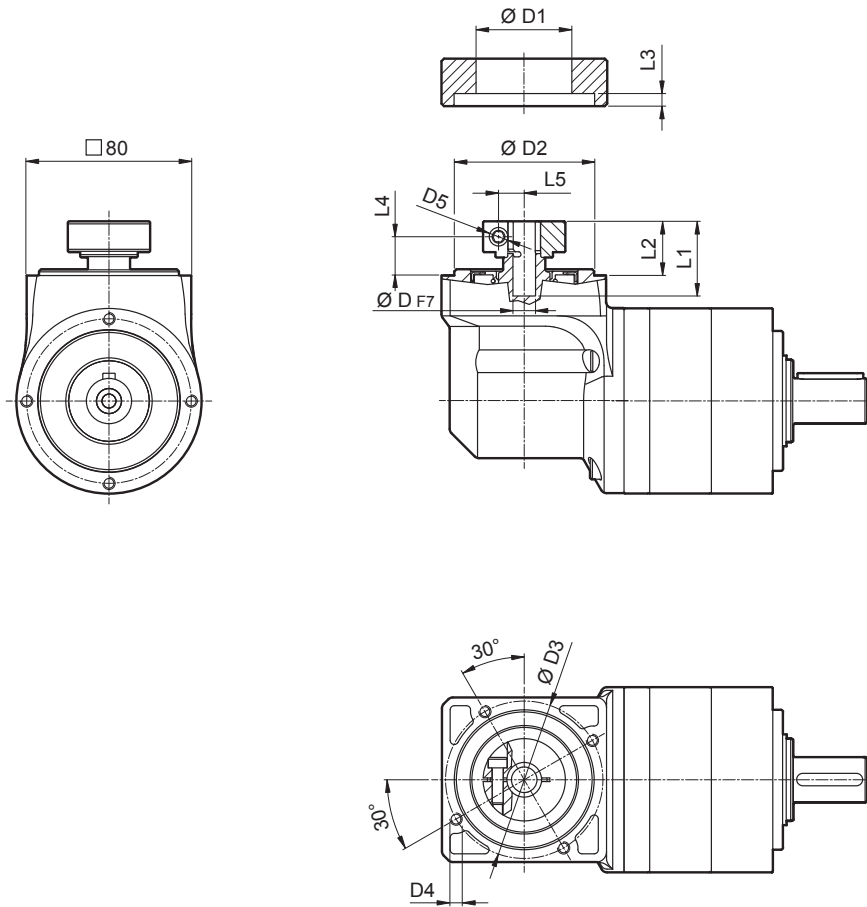

D				D1	D2	D3	D4	D5	L1	L2	L3	L4	L5
8	9	9.52		38	68	76.5	M6x10	M6	36.3	26.3	9.5	18.8	10.5
11	12	12.7		43	68	76.5	M6x10	M6	36.3	26.3	9.5	18.8	12.5
14	15.875	16	17	48	68	76.5	M6x10	M6	36.3	26.3	9.5	18.8	14.5
19	19.05			51	68	76.5	M6x10	M6	36.3	26.3	9.5	18.8	16.5

i	M _{n2}	M _{a2}	M _{p2}	n ₁	n _{1 max}	φ _s	C _t	R _{2 max}	A _{2 max}	η	J _G [kgcm ²]	
	[Nm]	[Nm]	[Nm]	[min ⁻¹]	[min ⁻¹]	[arcmin]	$\frac{Nm}{arcmin}$	[N]	[N]	%	8 ... 12.7	14 ... 19.05
LCK 090 2_6	37	63	90	2500	5000	6'	8	2200	1900	94	0.85	1.03
LCK 090 2_8	43	80	120	2500	5000	6'	8	2200	1900	94	0.79	0.98
LCK 090 2_10	43	80	150	2500	5000	6'	8	2200	1900	94	0.77	0.96
LCK 090 2_14	43	80	160	2500	5000	6'	8	2200	1900	94	0.75	0.94
LCK 090 2_20	37	70	150	2500	5000	6'	8	2200	1900	94	0.74	0.93
LCK 090 3_24	43	80	160	2500	5000	8'	7.8	2200	1900	91	0.81	1.00
LCK 090 3_30	43	80	160	2500	5000	8'	7.8	2200	1900	91	0.81	1.00
LCK 090 3_50	43	80	160	2500	5000	8'	7.8	2200	1900	91	0.76	0.94
LCK 090 3_70	43	80	160	2500	5000	8'	7.8	2200	1900	91	0.74	0.93
LCK 090 3_80	43	80	160	2500	5000	8'	7.8	2200	1900	91	0.74	0.93
LCK 090 3_100	43	80	160	2500	5000	8'	7.8	2200	1900	91	0.74	0.93

LCK

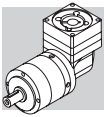

LCK 120

50D ... 130A1

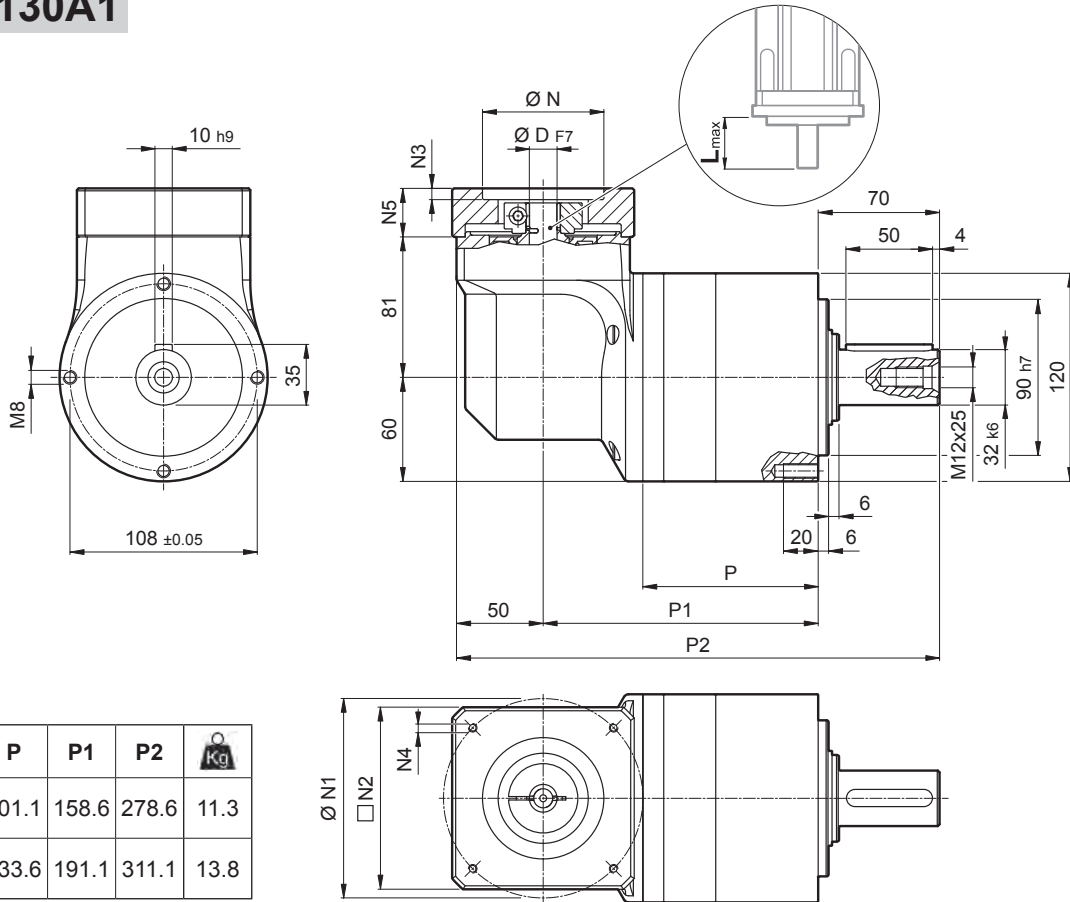

	P	P1	P2	
LCK 120 2	101.1	158.6	278.6	11.3
LCK 120 3	133.6	191.1	311.1	13.8

LCK

											N	N1	N2	N3	N4	N5	L _{max}
50D	11	12	12.7	14	15	15.875	16	19	-	-	50	95	100	5	M6x14	28	40
55A	11	12	12.7	14	15	15.875	16	19	-	-	55.5	125.7	105	5	M6x16	28	40
60A2	11	12	12.7	14	15	15.875	16	19	-	-	60	75	100	5	M5x14	28	40
60AH2	11	12	12.7	14	15	15.875	16	19	-	-	60	75	100	5	6.5	33	40
60B1	11	12	12.7	14	15	15.875	16	19	-	-	60	85	100	6.5	M5x14	28	40
70A1	11	12	12.7	14	15	15.875	16	19	-	-	70	85	100	5	M6x14	28	40
70AH1	11	12	12.7	14	15	15.875	16	19	-	-	70	85	100	5	6	33	40
70B1	11	12	12.7	14	15	15.875	16	19	-	-	70	90	100	5	M5x12	28	40
80A1	11	12	12.7	14	15	15.875	16	19	-	-	80	100	100	5	M6x16	28	40
80AH1	11	12	12.7	14	15	15.875	16	19	-	-	80	100	100	5	6.5	28	40
95A	11	12	12.7	14	15	15.875	16	19	-	-	95	115	100	5	M8x18	28	40
95A1	11	12	12.7	14	15	15.875	16	19	22	24	95	115	100	5	M8x18	38	50
95B	11	12	12.7	14	15	15.875	16	19	-	-	95	130	115	5	M8x18	28	40
110A	11	12	12.7	14	15	15.875	16	19	-	-	110	130	115	5	M8x18	28	40
110A1	11	12	12.7	14	15	15.875	16	19	22	24	110	130	115	6.5	M8x20	38	50
110B	11	12	12.7	14	15	15.875	16	19	22	24	110	145	120	6.5	M8x20	38	50
110B1	11	12	12.7	14	15	15.875	16	19	22	24	110	145	120	6.5	M8x20	48	60
130A	11	12	12.7	14	15	15.875	16	19	22	24	130	165	140	6.5	M10x20	38	50
130A1	11	12	12.7	14	15	15.875	16	19	22	24	130	165	140	6.5	M10x25	48	60

Für weitere Motoradapter und Antriebswellenbohrungen bitte nachfragen.

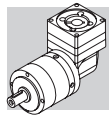

LCK 120

FM

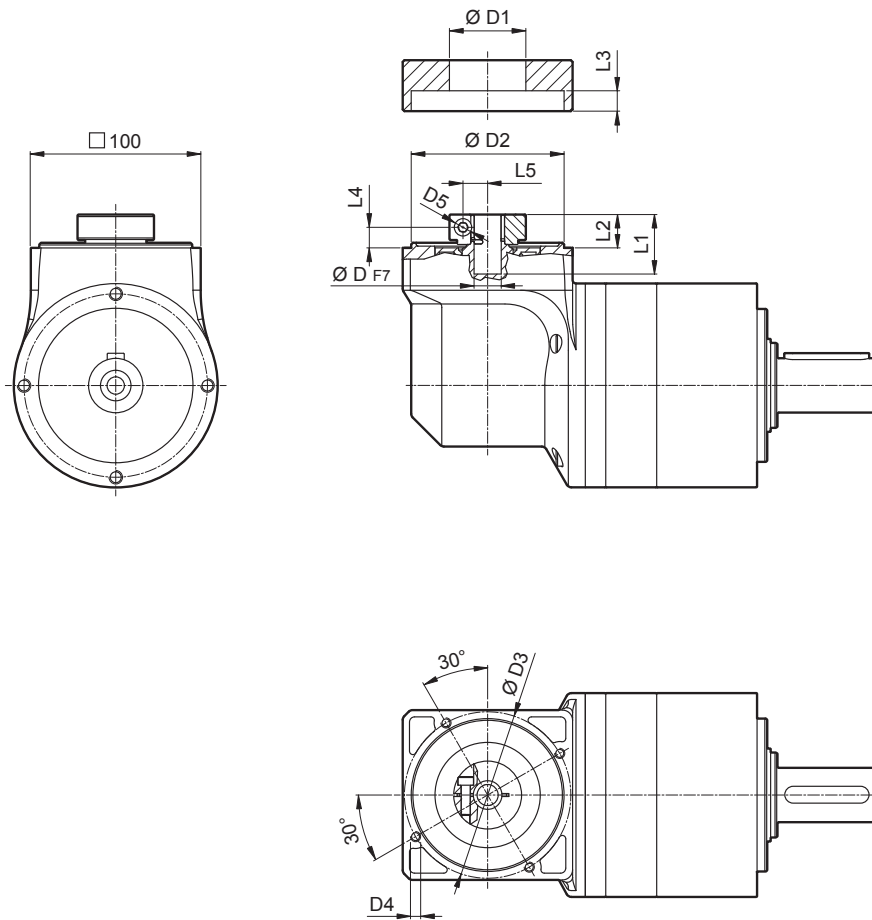

D				D1	D2	D3	D4	D5	L1	L2	L3	L4	L5
11	12	12.7		43	90	98	M6x15	M6	35	19.5	7.6	12.1	12.5
14	15	15.875	16	48	90	98	M6x15	M6	35	19.5	7.6	12.1	14.5
19				51	90	98	M6x15	M6	35	19.5	7.6	12.1	16.5
22	24			56.5	90	98	M6x15	M6	37	21.5	7.6	12.1	19

 i	M _{n 2}	M _{a 2}	M _{p 2}	n ₁	n _{1 max}	φ _s	C _t	R _{2 max}	A _{2 max}	η	J _G [kgcm ²]		
	[Nm]	[Nm]	[Nm]	[min ⁻¹]	[min ⁻¹]	[arcmin]	$\frac{Nm}{arcmin}$	[N]	[N]	%	11 ... 12.7	14 ... 19	22 ; 24
LCK 120 2_6	95	160	225	2000	4500	6'	23.4	3500	3000	94	1.74	1.82	2.01
LCK 120 2_8	110	190	300	2000	4500	6'	23.4	3500	3000	94	1.52	1.60	1.79
LCK 120 2_10	110	190	360	2000	4500	6'	23.4	3500	3000	94	1.44	1.52	1.71
LCK 120 2_14	110	190	360	2000	4500	6'	23.4	3500	3000	94	1.37	1.45	1.63
LCK 120 2_20	95	160	300	2000	4500	6'	23.4	3500	3000	94	1.32	1.40	1.59
LCK 120 3_24	110	190	360	2000	4500	8'	22.9	3500	3000	91	1.64	1.72	1.90
LCK 120 3_30	110	190	360	2000	4500	8'	22.9	3500	3000	91	1.63	1.71	1.89
LCK 120 3_50	110	190	360	2000	4500	8'	22.9	3500	3000	91	1.40	1.48	1.67
LCK 120 3_70	110	190	360	2000	4500	8'	22.9	3500	3000	91	1.34	1.42	1.61
LCK 120 3_80	110	190	360	2000	4500	8'	22.9	3500	3000	91	1.31	1.39	1.58
LCK 120 3_100	110	190	360	2000	4500	8'	22.9	3500	3000	91	1.31	1.39	1.58

LCK

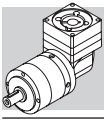

LCK 155

55A1 ... 180A1

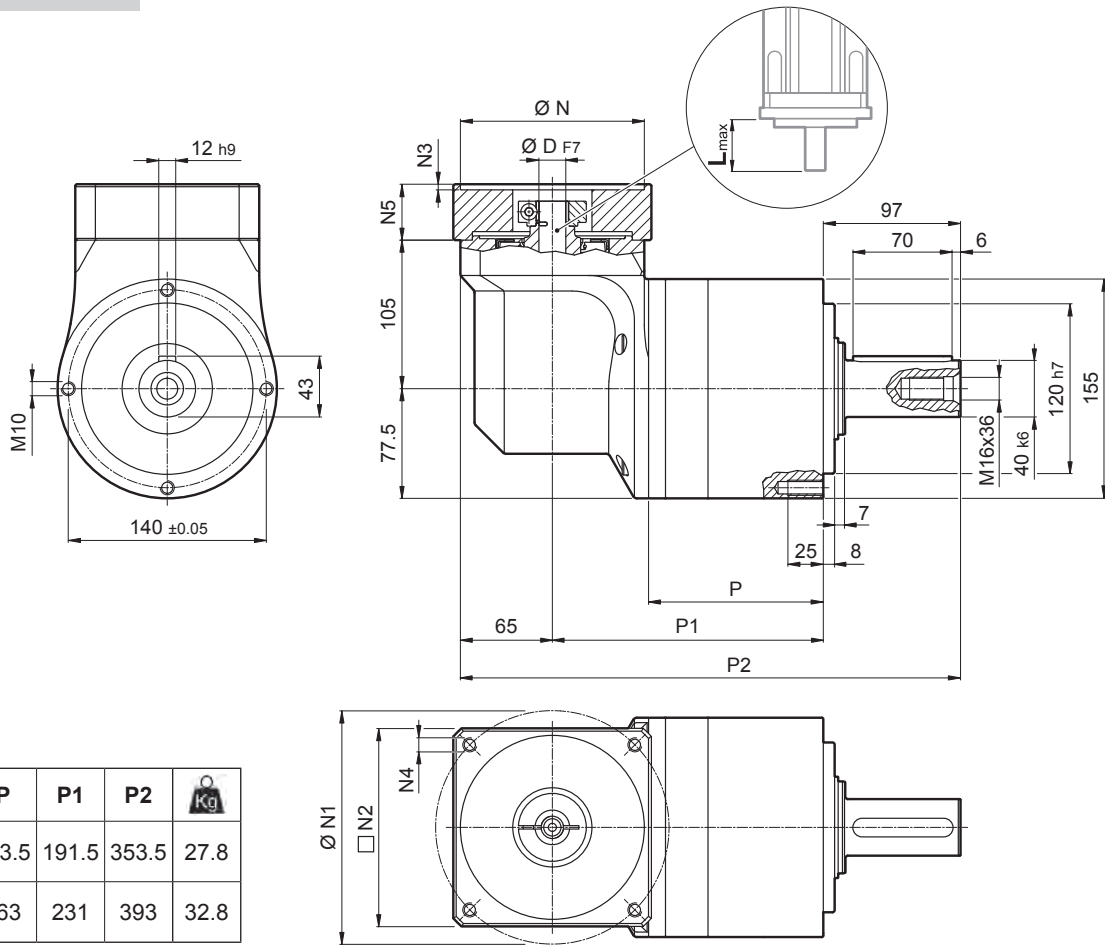

LCK									N	N1	N2	N3	N4	N5	L_max
		D	N	N1	N2	N3	N4	N5							
	55A1	14	15.875	16	19	-	-	-	55.5	125.7	130	4	M6x15	39.5	50
	80A2	14	15.875	16	19	-	-	-	80	100	130	4	M6x15	39.5	50
	95A1	14	15.875	16	19	22	24	-	95	115	130	4	M8x20	39.5	50
	110A1	14	15.875	16	19	22	24	-	110	130	130	4	M8x20	39.5	50
	110B1	14	15.875	16	19	22	24	-	110	145	130	6.5	M8x20	49.5	60
	114A	14	15.875	16	19	22	24	28	114.3	200	170	5.5	M12x25	69.5	80
	130A	14	15.875	16	19	22	24	-	130	165	140	4	M10x20	39.5	50
	130A1	14	15.875	16	19	22	24	28	130	165	140	4	M10x20	49.5	60
	180A	14	15.875	16	19	22	24	28	180	215	190	5.5	M14x25	49.5	60
	180A1	14	15.875	16	19	22	24	28	180	215	190	5.5	M14x25	69.5	80

Für weitere Motoradapter und Antriebswellenbohrungen bitte nachfragen.

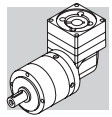

LCK 155

FM

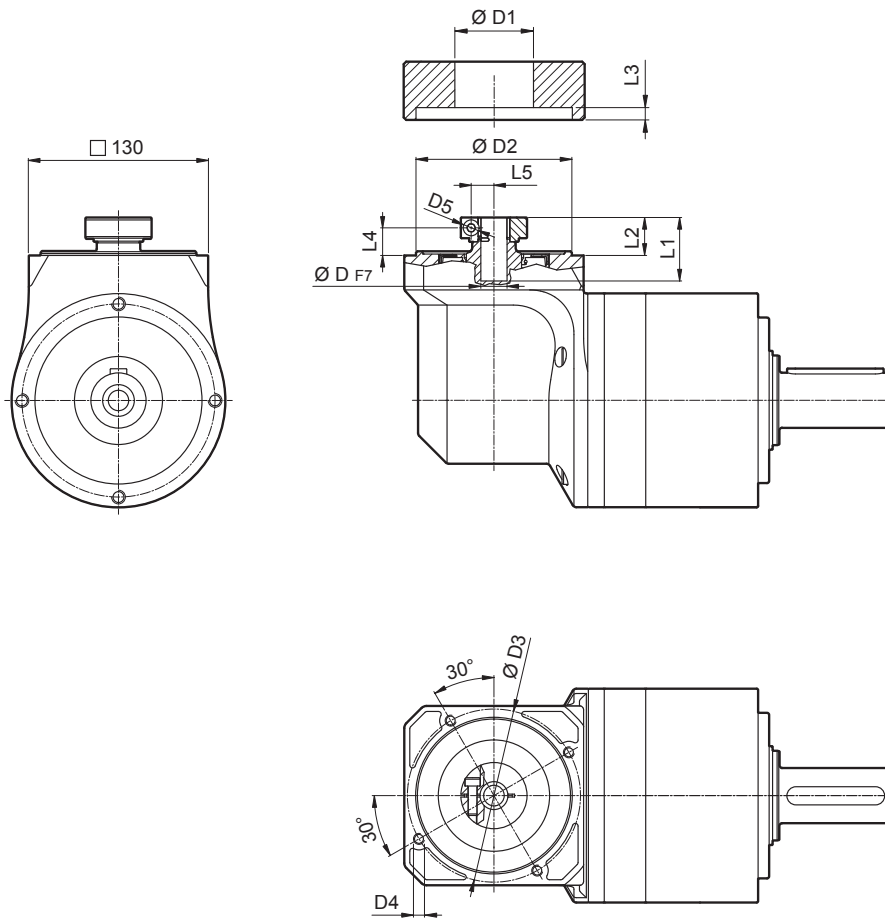

	D	D1	D2	D3	D4	D5	L1	L2	L3	L4	L5	
14	15.875	16	48	113	125.5	M8x15	M6	46	27.5	6	20	14.5
19			51	113	125.5	M8x15	M6	46	27.5	6	20	16.5
22	24		56.5	113	125.5	M8x15	M6	47.5	29	6	20	19
28			67	113	125.5	M8x15	M8	47.5	29	6	20	22.5

	i	M _{n2} [Nm]	M _{a2} [Nm]	M _{p2} [Nm]	n ₁ [min ⁻¹]	n _{1 max} [min ⁻¹]	ψ _s [arcmin]	C _t [$\frac{Nm}{arcmin}$]	R _{2 max} [N]	A _{2 max} [N]	η %	J _G [kgcm ²]		
													14 ... 19	22 ; 24
LCK 155 2_6		250	360	510	2000	4500	6'	40.7	6000	5000	94	7.94	8.13	8.53
LCK 155 2_8		300	450	680	2000	4500	6'	40.7	6000	5000	94	7.11	7.30	7.70
LCK 155 2_10		300	450	850	2000	4500	6'	40.7	6000	5000	94	6.78	6.96	7.36
LCK 155 2_14		300	450	900	2000	4500	6'	40.7	6000	5000	94	6.48	6.67	7.07
LCK 155 2_20		230	350	750	2000	4500	6'	40.7	6000	5000	94	6.31	6.49	6.90
LCK 155 3_24		300	450	900	2000	4500	8'	37.4	6000	5000	91	7.18	7.37	7.77
LCK 155 3_30		300	450	900	2000	4500	8'	37.4	6000	5000	91	7.14	7.33	7.73
LCK 155 3_50		300	450	900	2000	4500	8'	37.4	6000	5000	91	6.49	6.68	7.08
LCK 155 3_70		300	450	900	2000	4500	8'	37.4	6000	5000	91	6.33	6.52	6.92
LCK 155 3_80		300	450	700	2000	4500	8'	37.4	6000	5000	91	6.25	6.43	6.83
LCK 155 3_100		300	450	900	2000	4500	8'	37.4	6000	5000	91	6.24	6.43	6.83

LCK

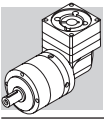

LCK 070P

25AH ... 80A

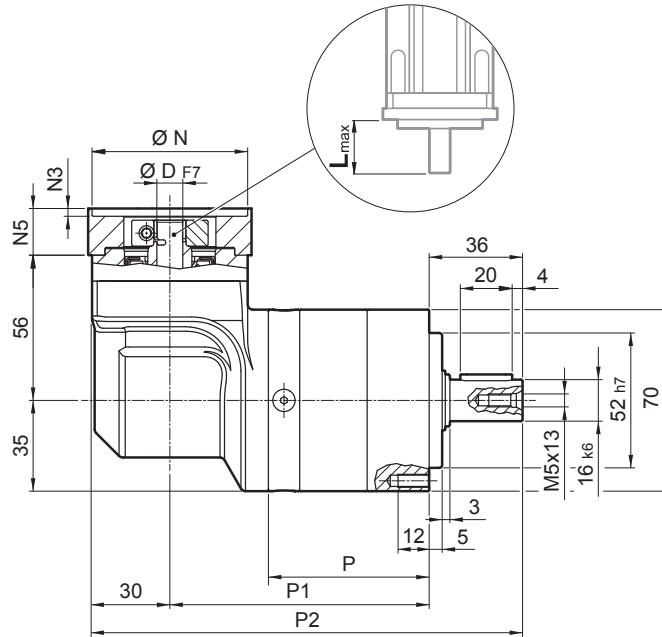
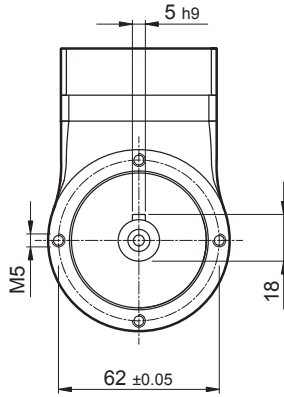

	P	P1	P2	kg
LCK 070P 2	62	100	166	2.7
LCK 070P 3	78.7	116.7	182.7	3.0

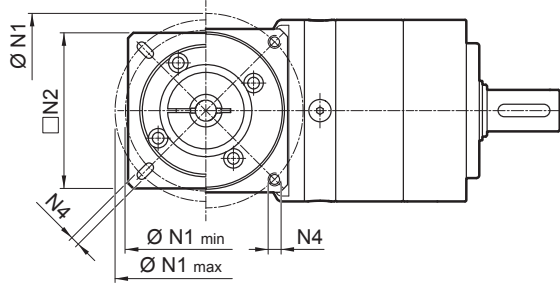
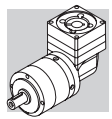

Image	D											N	N1		N2	N3	N4	N5	L _{max}
		6	7	8	9	9.52	10	11	12	12.7	14		min	max					
25AH	6	6.35	7	8	9	9.52	-	-	-	-	-	25	39	56					
26AH	6	6.35	7	8	9	9.52	-	-	-	-	-	26	39	56					
28AH	6	6.35	7	8	9	9.52	-	-	-	-	-	28	39	56					
30AH	6	6.35	7	8	9	9.52	-	-	-	-	-	30	39	56					
32AH	6	6.35	7	8	9	9.52	-	-	-	-	-	32	39	56	65	3.5	4.5	25	25
34AH	6	6.35	7	8	9	9.52	-	-	-	-	-	34	40	56					
36AH	6	6.35	7	8	9	9.52	-	-	-	-	-	36	42	56					
39AH	6	6.35	7	8	9	9.52	-	-	-	-	-	39	45	56					
40AH	6	6.35	7	8	9	9.52	-	-	-	-	-	40	46	56					
38B	6	6.35	7	8	9	9.52	10	11	12	12.7	-	38.1	66.6	60	3	M4x10	18	25	
40B	6	6.35	7	8	9	9.52	10	11	12	12.7	-	40	63	60	3	M4x10	18	25	
50A	6	6.35	7	8	9	9.52	10	11	12	12.7	-	50	60	60	3	M4x10	18	25	
50B	6	6.35	7	8	9	9.52	10	11	12	12.7	14	50	65	60	3	M5x12	23	30	
50BH	6	6.35	7	8	9	9.52	10	11	12	12.7	14	50	65	65	3	5.5	25	32	
50C	6	6.35	7	8	9	9.52	10	11	12	12.7	14	50	70	60	3	M4x10	23	30	
55MH	6	6.35	7	8	9	9.52	10	11	12	12.7	-	55	80	65	2	5.5	16	23	
60A	6	6.35	7	8	9	9.52	10	11	12	12.7	-	60	75	65	3	M5x12	18	25	
60A1	6	6.35	7	8	9	9.52	10	11	12	12.7	14	60	75	65	3	M5x12	23	30	
60B	6	6.35	7	8	9	9.52	10	11	12	12.7	14	60	85	75	3	M5x12	23	30	
60C	6	6.35	7	8	9	9.52	10	11	12	12.7	14	60	90	75	3	M5x12	23	30	
70A	6	6.35	7	8	9	9.52	10	11	12	12.7	14	70	85	75	3	M6x15	23	30	
70B	6	6.35	7	8	9	9.52	10	11	12	12.7	14	70	90	75	3	M5x12	23	30	
73A	6	6.35	7	8	9	9.52	10	11	12	12.7	14	73	98.4	85	3	M5x12	25	32	
80A	6	6.35	7	8	9	9.52	10	11	12	12.7	14	80	100	85	3	M6x15	23	30	

Für weitere Motoradapter und Antriebswellenbohrungen bitte nachfragen.

LCK



LCK 070P

FM

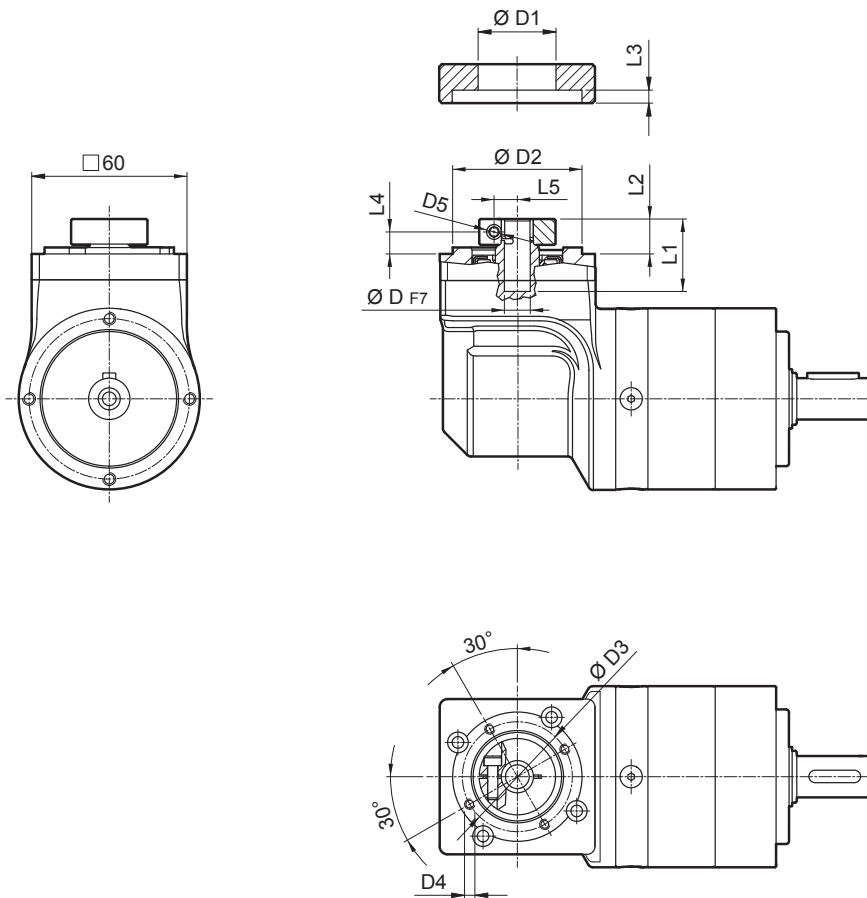

D	D			D1	D2	D3	D4	D5	L1	L2	L3	L4	L5
	6	8	11										
6	6.35	7		32.5	50	42.5	M4x8	M4	28	13.5	3	8.5	8
8	9	9.52	10	32.5	50	42.5	M4x8	M4	28	13.5	3	8.5	9
11	12	12.7		35.5	50	42.5	M4x8	M4	23	13.5	3	8.5	11
14				35.5	50	42.5	M4x8	M4	25	15.5	3	8.9	11.5

i	M_{n2} [Nm]	M_{a2} [Nm]	M_{p2} [Nm]	n_1 [min ⁻¹]	n_{1max} [min ⁻¹]	φ_s [arcmin]	C_t [$\frac{Nm}{arcmin}$]	R_{2max} [N]	A_{2max} [N]	η %	J_G [kgcm ²]	
											6 ... 9.52	11 ... 14
LCK 070P 2_6	25	38	45	2500	5000	6'	2.8	1300	1400	94	0.25	0.26
LCK 070P 2_8	30	40	60	2500	5000	6'	2.8	1300	1400	94	0.24	0.25
LCK 070P 2_10	25	40	70	2500	5000	6'	2.8	1300	1400	94	0.23	0.25
LCK 070P 2_14	25	40	70	2500	5000	6'	2.8	1300	1400	94	0.23	0.24
LCK 070P 2_20	18	30	60	2500	5000	6'	2.8	1300	1400	94	0.23	0.24
LCK 070P 3_24	29	45	70	2500	5000	8'	2.5	1300	1400	91	0.24	0.26
LCK 070P 3_30	29	45	70	2500	5000	8'	2.5	1300	1400	91	0.24	0.26
LCK 070P 3_50	30	45	70	2500	5000	8'	2.5	1300	1400	91	0.23	0.24
LCK 070P 3_70	30	45	70	2500	5000	8'	2.5	1300	1400	91	0.23	0.24
LCK 070P 3_80	30	45	70	2500	5000	8'	2.5	1300	1400	91	0.23	0.24
LCK 070P 3_100	30	45	70	2500	5000	8'	2.5	1300	1400	91	0.23	0.24

LCK

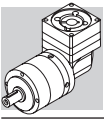

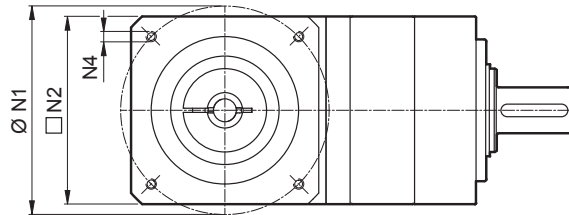
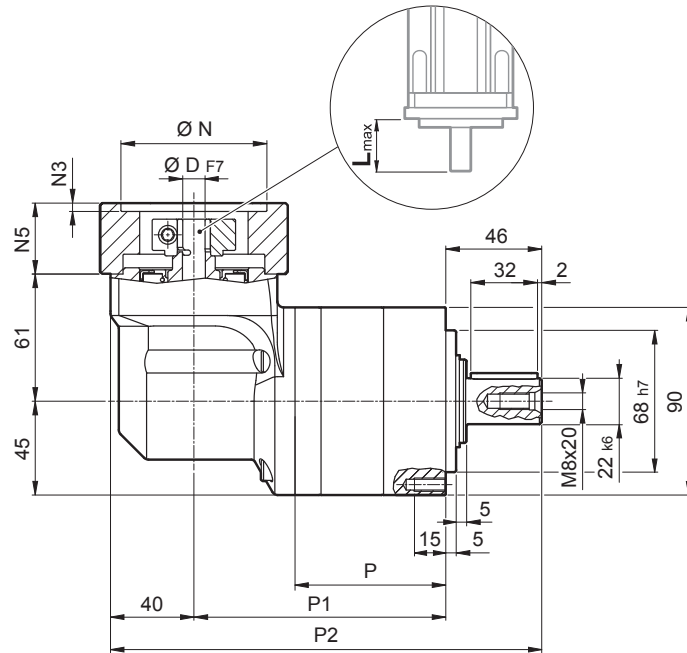
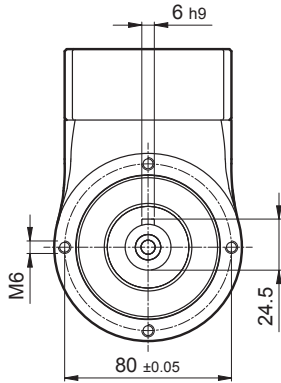

LCK 090P

40B1 ... 110B1



	P	P1	P2	
LCK 090P 2	72.3	120.8	206.8	5.2
LCK 090P 3	98.8	147.3	233.3	6.3

												N	N1	N2	N3	N4	N5	L _{max}	
40B1	8	9	9.52	11	12	12.7	14	-	-	-	-	40	63	80	4	M4x10	34	40	
45A	8	9	9.52	11	12	12.7	-	-	-	-	-	45	63	80	4	M4x10	34	40	
50B1	8	9	9.52	11	12	12.7	14	-	-	-	-	50	65	80	4	M5x16	34	40	
50BH1	8	9	9.52	11	12	12.7	14	-	-	-	-	50	65	80	4	5.5	34	40	
50C1	8	9	9.52	11	12	12.7	14	-	-	-	-	50	70	80	4	M4x10	34	40	
50D	8	9	9.52	11	12	12.7	14	-	-	-	-	50	95	80	4	M6x10	34	40	
55A	8	9	9.52	11	12	12.7	14	15.875	16	17	19	19.05	55.5	125.7	105	4	M6x16	34	40
60A2	8	9	9.52	11	12	12.7	14	-	-	-	-	60	75	80	4	M5x16	34	40	
60AH2	8	9	9.52	11	12	12.7	14	-	-	-	-	60	75	90	4	5.5	34	40	
60B1	8	9	9.52	11	12	12.7	14	15.875	16	-	-	60	85	80	4	M5x16	34	40	
60C1	8	9	9.52	11	12	12.7	14	15.875	16	-	-	60	90	80	4	M5x16	34	40	
70A1	8	9	9.52	11	12	12.7	14	15.875	16	17	19	19.05	70	85	80	4	M6x20	34	40
70AH1	8	9	9.52	11	12	12.7	14	15.875	16	17	19	19.05	70	85	90	4	6.5	34	40
70B1	8	9	9.52	11	12	12.7	14	15.875	16	17	19	19.05	70	90	80	4	M5x16	34	40
73A1	8	9	9.52	11	12	12.7	14	-	-	-	-	73	98.4	85	4	M5x16	34	40	
80A1	8	9	9.52	11	12	12.7	14	15.875	16	17	19	19.05	80	100	90	4	M6x16	34	40
95A	8	9	9.52	11	12	12.7	14	15.875	16	17	19	19.05	95	115	100	4	M8x20	34	40
95B	8	9	9.52	11	12	12.7	14	15.875	16	17	19	19.05	95	130	115	4	M8x20	34	40
110A	8	9	9.52	11	12	12.7	14	15.875	16	17	19	19.05	110	130	115	4	M8x20	34	40
110B	8	9	9.52	11	12	12.7	14	15.875	16	17	19	19.05	110	145	120	6.5	M8x20	44	50
110B1	8	9	9.52	11	12	12.7	14	15.875	16	17	19	19.05	110	145	120	6.5	M8x20	54	60

Für weitere Motoradapter und Antriebswellenbohrungen bitte nachfragen.

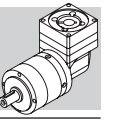

LCK 090P

FM

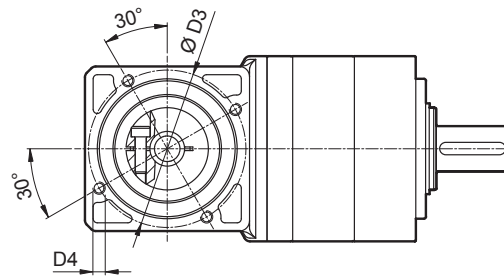
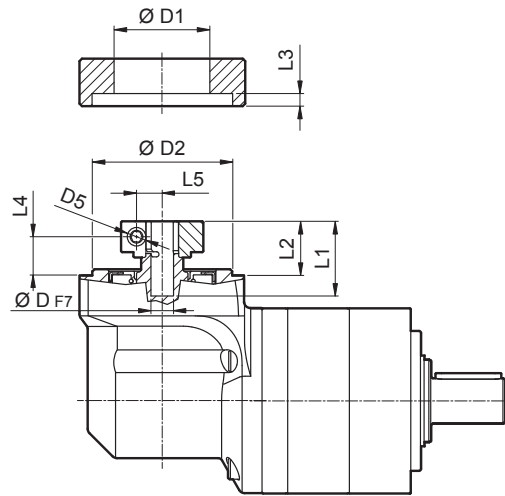
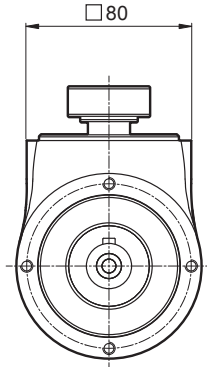

D				D1	D2	D3	D4	D5	L1	L2	L3	L4	L5
8	9	9.52		38	68	76.5	M6x10	M6	36.3	26.3	9.5	18.8	10.5
11	12	12.7		43	68	76.5	M6x10	M6	36.3	26.3	9.5	18.8	12.5
14	15.875	16	17	48	68	76.5	M6x10	M6	36.3	26.3	9.5	18.8	14.5
19	19.05			51	68	76.5	M6x10	M6	36.3	26.3	9.5	18.8	16.5

i	M_{n2} [Nm]	M_{a2} [Nm]	M_{p2} [Nm]	n_1 [min ⁻¹]	n_{1max} [min ⁻¹]	φ_s [arcmin]	C_t [Nm/arcmin]	R_{2max} [N]	A_{2max} [N]	η %	J_G [kgcm ²]	
											8 ... 12.7	14 ... 19
LCK 090P 2_6	45	70	90	2500	5000	6'	11	2200	1900	94	0.85	1.03
LCK 090P 2_8	60	90	120	2500	5000	6'	11	2200	1900	94	0.79	0.98
LCK 090P 2_10	50	90	150	2500	5000	6'	8	2200	1900	94	0.77	0.96
LCK 090P 2_14	50	90	160	2500	5000	6'	8	2200	1900	94	0.75	0.94
LCK 090P 2_20	40	70	150	2500	5000	6'	8	2200	1900	94	0.74	0.93
LCK 090P 3_24	60	90	160	2500	5000	8'	10.8	2200	1900	91	0.81	1.00
LCK 090P 3_30	60	90	160	2500	5000	8'	10.8	2200	1900	91	0.81	1.00
LCK 090P 3_50	50	90	160	2500	5000	8'	7.8	2200	1900	91	0.76	0.94
LCK 090P 3_70	50	90	160	2500	5000	8'	7.8	2200	1900	91	0.74	0.93
LCK 090P 3_80	60	90	160	2500	5000	8'	10.8	2200	1900	91	0.74	0.93
LCK 090P 3_100	50	90	160	2500	5000	8'	7.8	2200	1900	91	0.74	0.93

LCK

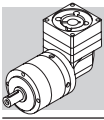

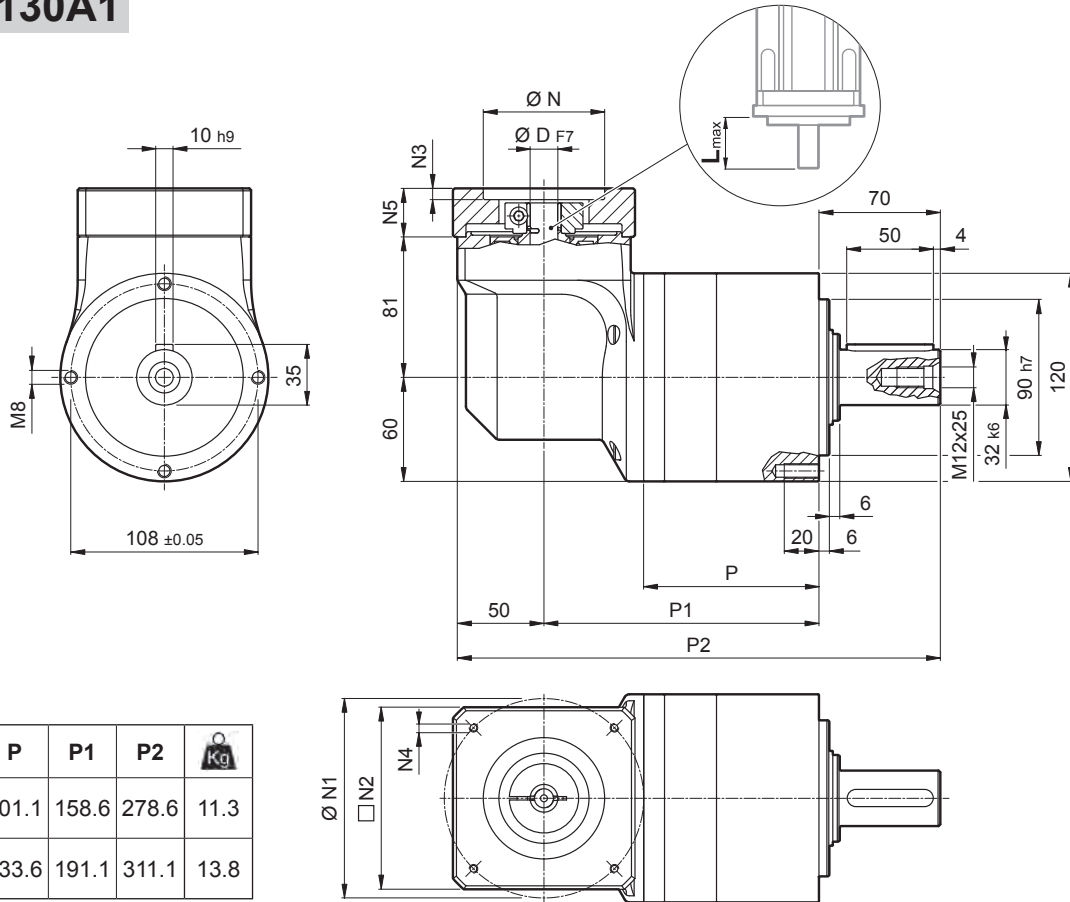

LCK 120P

50D ... 130A1



	P	P1	P2	
LCK 120P 2	101.1	158.6	278.6	11.3
LCK 120P 3	133.6	191.1	311.1	13.8

											N	N1	N2	N3	N4	N5	Lmax
50D	11	12	12.7	14	15	15.875	16	19	-	-	50	95	100	5	M6x14	28	40
55A	11	12	12.7	14	15	15.875	16	19	-	-	55.5	125.7	105	5	M6x16	28	40
60A2	11	12	12.7	14	15	15.875	16	19	-	-	60	75	100	5	M5x14	28	40
60AH2	11	12	12.7	14	15	15.875	16	19	-	-	60	75	100	5	6.5	33	40
60B1	11	12	12.7	14	15	15.875	16	19	-	-	60	85	100	6.5	M5x14	28	40
70A1	11	12	12.7	14	15	15.875	16	19	-	-	70	85	100	5	M6x14	28	40
70AH1	11	12	12.7	14	15	15.875	16	19	-	-	70	85	100	5	6	33	40
70B1	11	12	12.7	14	15	15.875	16	19	-	-	70	90	100	5	M5x12	28	40
80A1	11	12	12.7	14	15	15.875	16	19	-	-	80	100	100	5	M6x16	28	40
80AH1	11	12	12.7	14	15	15.875	16	19	-	-	80	100	100	5	6.5	28	40
95A	11	12	12.7	14	15	15.875	16	19	-	-	95	115	100	5	M8x18	28	40
95A1	11	12	12.7	14	15	15.875	16	19	22	24	95	115	100	5	M8x18	38	50
95B	11	12	12.7	14	15	15.875	16	19	-	-	95	130	115	5	M8x18	28	40
110A	11	12	12.7	14	15	15.875	16	19	-	-	110	130	115	5	M8x18	28	40
110A1	11	12	12.7	14	15	15.875	16	19	22	24	110	130	115	6.5	M8x20	38	50
110B	11	12	12.7	14	15	15.875	16	19	22	24	110	145	120	6.5	M8x20	38	50
110B1	11	12	12.7	14	15	15.875	16	19	22	24	110	145	120	6.5	M8x20	48	60
130A	11	12	12.7	14	15	15.875	16	19	22	24	130	165	140	6.5	M10x20	38	50
130A1	11	12	12.7	14	15	15.875	16	19	22	24	130	165	140	6.5	M10x25	48	60

Für weitere Motoradapter und Antriebswellenbohrungen bitte nachfragen.

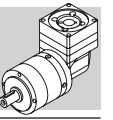

LCK 120P

FM

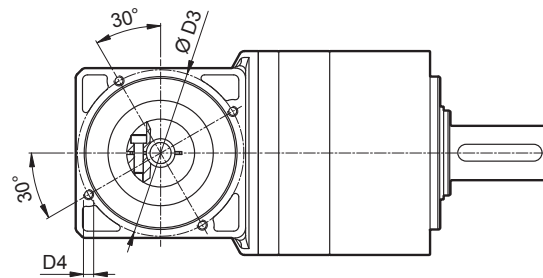
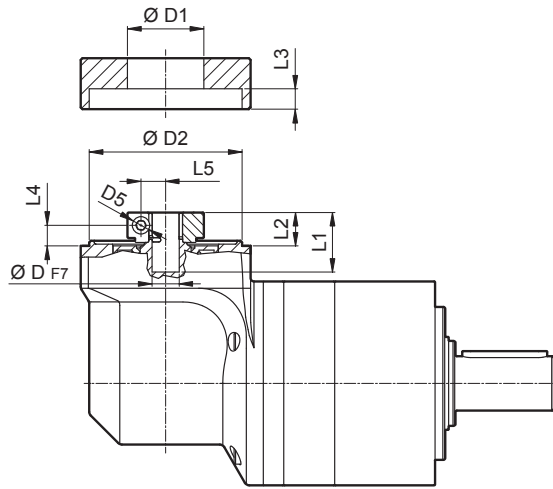
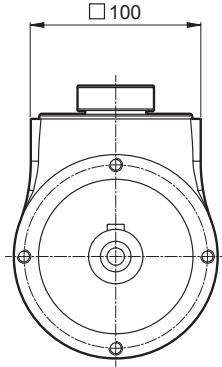

D				D1	D2	D3	D4	D5	L1	L2	L3	L4	L5
11	12	12.7		43	90	98	M6x15	M6	35	19.5	7.6	12.1	12.5
14	15	15.875	16	48	90	98	M6x15	M6	35	19.5	7.6	12.1	14.5
19				51	90	98	M6x15	M6	35	19.5	7.6	12.1	16.5
22	24			56.5	90	98	M6x15	M6	37	21.5	7.6	12.1	19

 i	M _{n 2}	M _{a 2}	M _{p 2}	n ₁	n _{1 max}	φ _s	C _t	R _{2 max}	A _{2 max}	η	J _G [kgcm ²]		
	[Nm]	[Nm]	[Nm]	[min ⁻¹]	[min ⁻¹]	[arcmin]	$\frac{Nm}{arcmin}$	[N]	[N]	%	14 ... 19	22 ; 24	28 ; 32
LCK 120P 2_6	110	160	225	2000	4500	6'	28.4	3500	3000	94	1.74	1.82	2.01
LCK 120P 2_8	140	220	300	2000	4500	6'	28.4	3500	3000	94	1.52	1.60	1.79
LCK 120P 2_10	125	220	360	2000	4500	6'	28.4	3500	3000	94	1.44	1.52	1.71
LCK 120P 2_14	125	220	360	2000	4500	6'	28.4	3500	3000	94	1.37	1.45	1.63
LCK 120P 2_20	100	160	300	2000	4500	6'	28.4	3500	3000	94	1.32	1.40	1.59
LCK 120P 3_24	155	220	360	2000	4500	8'	28.4	3500	3000	91	1.64	1.72	1.90
LCK 120P 3_30	155	220	360	2000	4500	8'	28.4	3500	3000	91	1.63	1.71	1.89
LCK 120P 3_50	125	220	360	2000	4500	8'	22.9	3500	3000	91	1.40	1.48	1.67
LCK 120P 3_70	125	220	360	2000	4500	8'	22.9	3500	3000	91	1.34	1.42	1.61
LCK 120P 3_80	155	220	360	2000	4500	8'	28.4	3500	3000	91	1.31	1.39	1.58
LCK 120P 3_100	125	220	360	2000	4500	8'	22.9	3500	3000	91	1.31	1.39	1.58

LCK

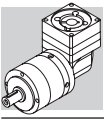

LCK 155P

55A1 ... 180A1

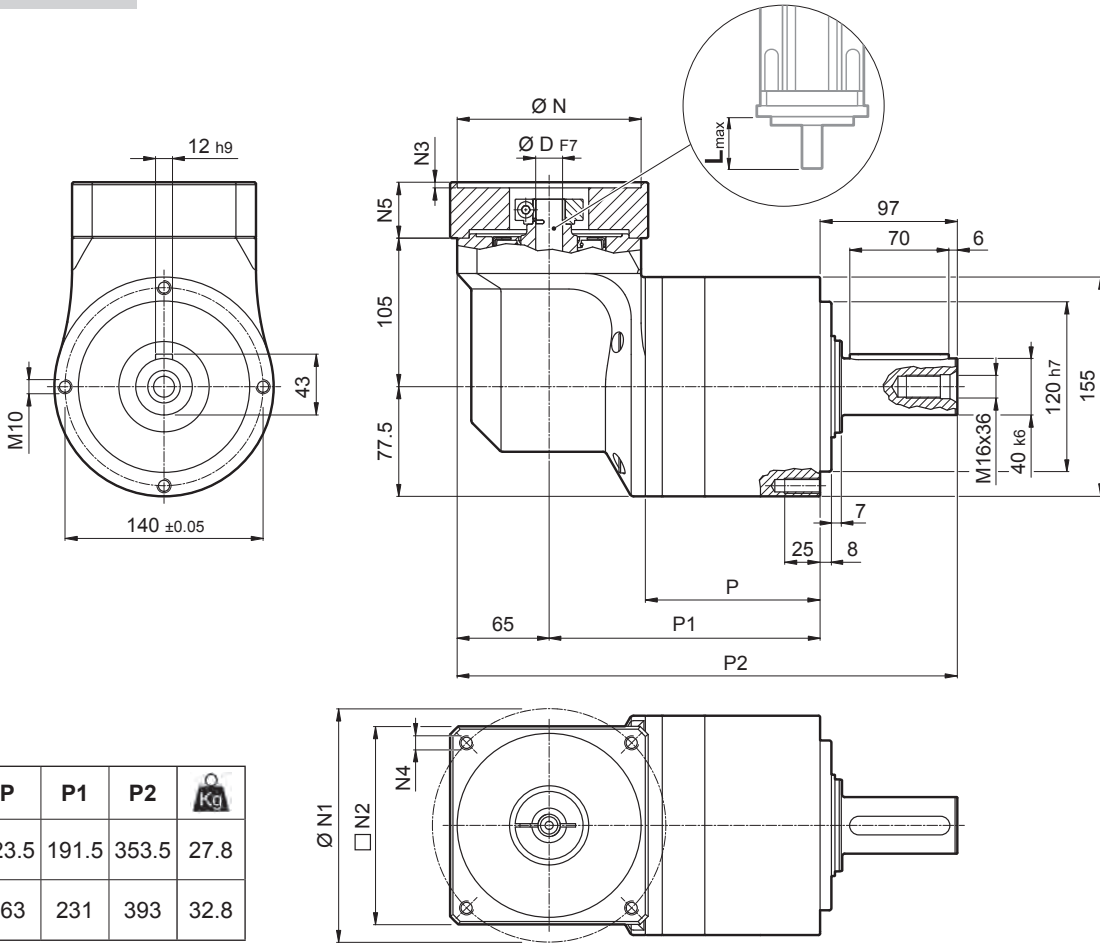

	P	P1	P2	Kg
LCK 155P 2	123.5	191.5	353.5	27.8
LCK 155P 3	163	231	393	32.8

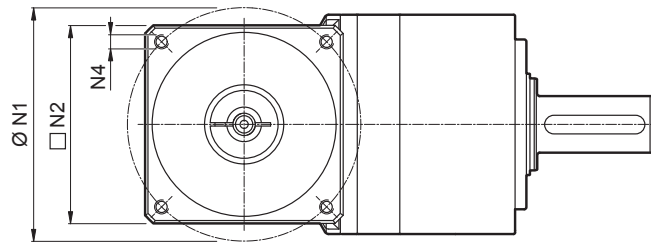

								N	N1	N2	N3	N4	N5	L _{max}
55A1	14	15.875	16	19	-	-	-	55.5	125.7	130	4	M6x15	39.5	50
80A2	14	15.875	16	19	-	-	-	80	100	130	4	M6x15	39.5	50
95A1	14	15.875	16	19	22	24	-	95	115	130	4	M8x20	39.5	50
110A1	14	15.875	16	19	22	24	-	110	130	130	4	M8x20	39.5	50
110B1	14	15.875	16	19	22	24	-	110	145	130	6.5	M8x20	49.5	60
114A	14	15.875	16	19	22	24	28	114.3	200	170	5.5	M12x25	69.5	80
130A	14	15.875	16	19	22	24	-	130	165	140	4	M10x20	39.5	50
130A1	14	15.875	16	19	22	24	28	130	165	140	4	M10x20	49.5	60
180A	14	15.875	16	19	22	24	28	180	215	190	5.5	M14x25	49.5	60
180A1	14	15.875	16	19	22	24	28	180	215	190	5.5	M14x25	69.5	80

Für weitere Motoradapter und Antriebswellenbohrungen bitte nachfragen.

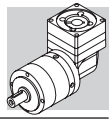

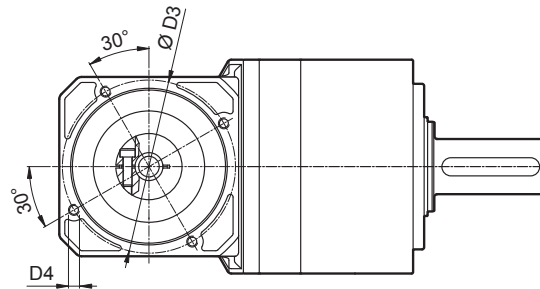
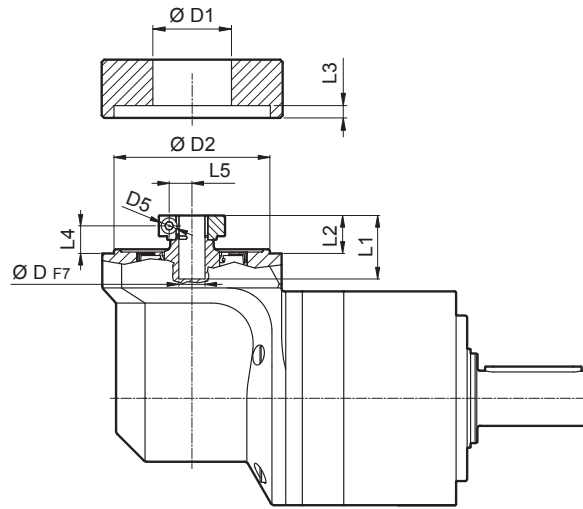
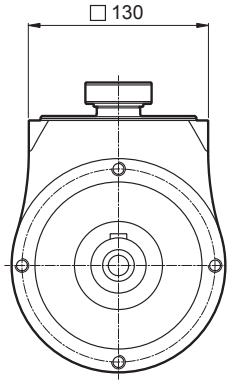

LCK 155P

FM



	D	D1	D2	D3	D4	D5	L1	L2	L3	L4	L5	
14	15.875	16	48	113	125.5	M8x15	M6	46	27.5	6	20	14.5
19			51	113	125.5	M8x15	M6	46	27.5	6	20	16.5
22	24		56.5	113	125.5	M8x15	M6	47.5	29	6	20	19
28			67	113	125.5	M8x15	M8	47.5	29	6	20	22.5

	i	M _{n2} [Nm]	M _{a2} [Nm]	M _{p2} [Nm]	n ₁ [min ⁻¹]	n _{1 max} [min ⁻¹]	φ _s [arcmin]	C _t [$\frac{Nm}{arcmin}$]	R _{2 max} [N]	A _{2 max} [N]	η %	J _G [kgcm ²]		
													14 ... 19	22 ; 24
LCK 155P 2_6		250	380	600	2000	4500	6'	47.9	6000	5000	94	7.94	8.13	8.53
LCK 155P 2_8		350	500	1000	2000	4500	6'	47.9	6000	5000	94	7.11	7.30	7.70
LCK 155P 2_10		350	500	1000	2000	4500	6'	47.9	6000	5000	94	6.78	6.96	7.36
LCK 155P 2_14		350	500	1000	2000	4500	6'	47.9	6000	5000	94	6.48	6.67	7.07
LCK 155P 2_20		230	350	750	2000	4500	6'	47.9	6000	5000	94	6.31	6.49	6.90
LCK 155P 3_24		450	700	1000	2000	4500	8'	44.6	6000	5000	91	7.18	7.37	7.77
LCK 155P 3_30		450	700	1000	2000	4500	8'	44.6	6000	5000	91	7.14	7.33	7.73
LCK 155P 3_50		450	700	1000	2000	4500	8'	44.6	6000	5000	91	6.49	6.68	7.08
LCK 155P 3_70		450	700	1000	2000	4500	8'	44.6	6000	5000	91	6.33	6.52	6.92
LCK 155P 3_80		450	700	1000	2000	4500	8'	44.6	6000	5000	91	6.25	6.43	6.83
LCK 155P 3_100		450	700	1000	2000	4500	8'	44.6	6000	5000	91	6.24	6.43	6.83

LCK

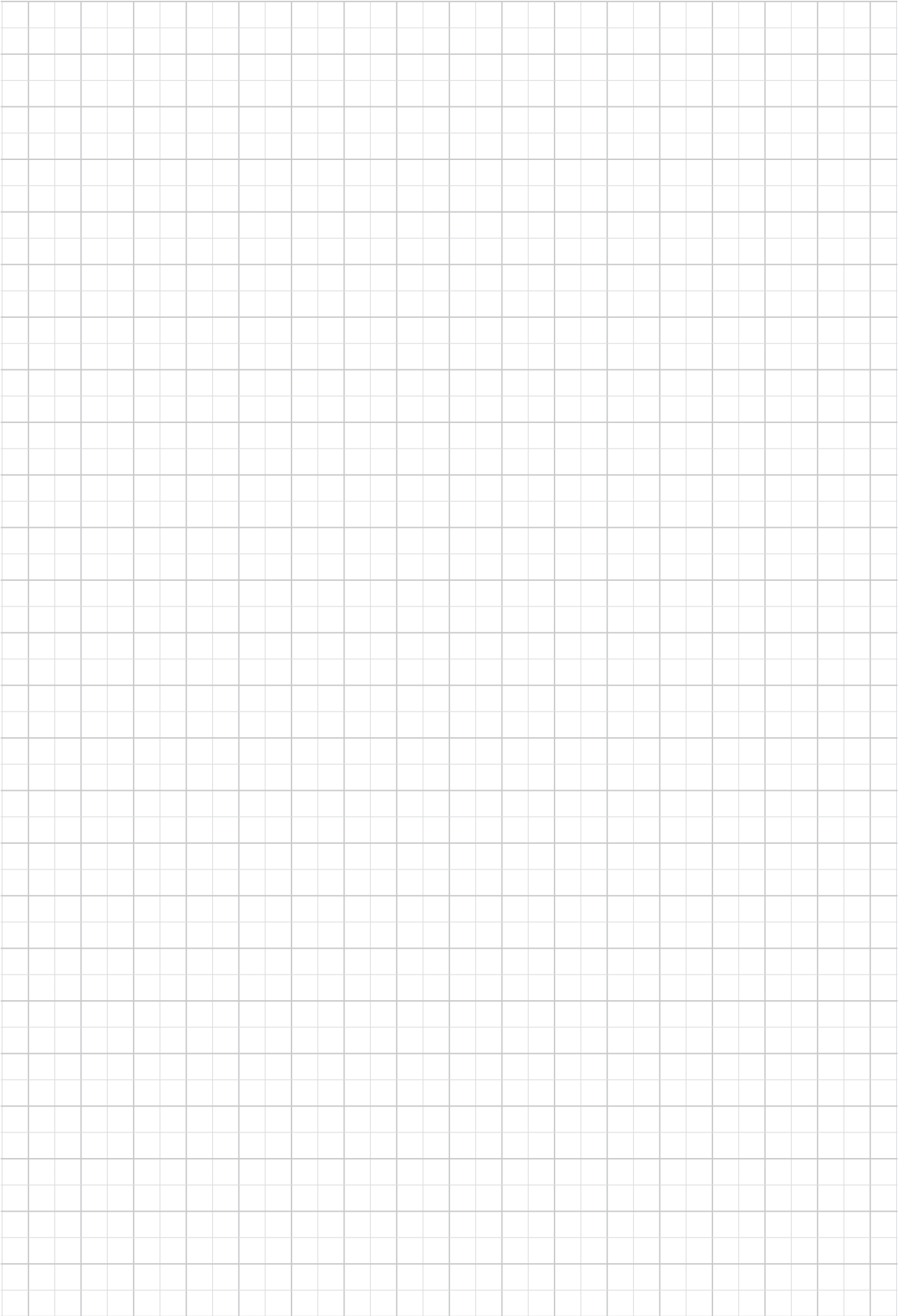
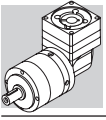

LCK

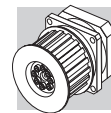

SL PRÄZISIONSPLANETENGETRIEBE FÜR RIEMENANTRIEBE

Das SL-Präzisionsplanetengetriebe für Riemenantriebe ist konkurrenzlos, wenn es um Kompaktheit, Effizienz und optimale Eignung für den Einsatz mit Zahnriemenantrieben geht.

Diese Getriebe sind die ideale Ergänzung für Servoantriebssysteme in Anwendungen, die eine Kombination aus Präzision und hohen Querkräften mit extrem kompakten Abmessungen erfordern.

Verbesserte Leistungsfähigkeit als Schlüssel zum Downsizing.

Die verbesserte Leistungsfähigkeit unseres LC-Präzisionsgetriebes (neue Option "P") kann wichtige Downsizing-Optionen für zahlreiche Anwendungen eröffnen, bei denen es zuvor nicht möglich war, ein höheres übertragbares Abtriebsdrehmoment bereitzustellen.

Ein weiterer Vorteil des Downsizing ist eine verbesserte Energieeffizienz, indem man ein kompakteres Getriebe mit höherer Drehmomentdichte wählen und dadurch die Beschleunigungsmasse deutlich reduzieren kann. Das übertragbare Drehmoment wurde um bis zu 40% verbessert.



Produktmerkmale:

- Option "P" mit hoher Drehmomentdichte für eine größere Produktleistungsfähigkeit verfügbar
- Hohes Beschleunigungs- und Nenndrehmoment
- Hohe radiale und axiale Belastbarkeit
- Entwickelt für Zyklus- und Dauerbetrieb
- Hohe Verdrehsteifigkeit
- Niedriges Verdrehflankenspiel – unter 6 arcmin
- Optional mit Zahnriemenscheibe erhältlich
- Laufruhig
- Einsetzbar in beliebiger Montageposition

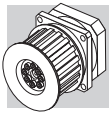

9 MERKMALE DER SL-REIHE

Die SL-Reihe ist konkurrenzlos, wenn es um Kompaktheit, Effizienz und optimale Eignung für den Einsatz mit Zahnriemenantrieben geht. Die spielarmen Getriebe der SL-Reihe sind die ideale Ergänzung für Servoantriebssysteme in Anwendungen, die eine Kombination aus Präzision und hohen Querkräften mit extrem kompakten Abmessungen erfordern.

- Erhältlich entweder mit standard (STD) oder reduziertem (LOW) Flankenspiel:
 - 1-stufige Getriebe: standard $\varphi_S \leq 12'$; reduziert $\varphi_R \leq 6'$
 - 2-stufige Getriebe: standard $\varphi_S \leq 15'$; reduziert $\varphi_R \leq 8'$
- Eine hohe IP-Schutzklasse (IP64) sorgt dafür, dass innenliegende Teile vor Staub- und Flüssigkeitseintritt geschützt sind.
- Serienmäßige Fluorelastomer-Wellendichtungen an der Eingangswelle.
- Schalldruckpegel $L_P \leq 70$ dB(A). Gemessen in 1 m Abstand ohne Last und bei einer Eingangsdrehzahl von $n_1 = 3000 \text{ min}^{-1}$; $i=10$.
- Die Getriebe sind werkseitig mit synthetischem Schmierfett gemäß NLGI-Konsistenzklasse 00 gefüllt; ohne Verunreinigung muss das Schmiermittel nicht regelmäßig gewechselt werden.
- AUmgebungstemperatur min. -20°C , max. $+30^\circ\text{C}$; bei Temperaturen höher als 30°C ist der Temperaturfaktor f_T zu berücksichtigen.
- Die Gehäusetemperatur darf $T_{\text{max}} = 90^\circ\text{C}$ nicht übersteigen
- Erhältlich als Version P mit höherem Abtriebsdrehmoment.

		Übersicht der Nenndrehmomente M_{n2} [Nm]																	
	[i]	3	4	5	7	9	10	12	15	16	20	25	28	30	35	40	50	70	100
SL 070		18	25	25	25	18	18	25	25	25	25	25	25	18	25	25	25	25	18
SL 070P		29	30	25	25	29	18	29	29	30	30	30	30	29	30	30	30	30	18
SL 090		37	43	43	43	37	37	43	43	43	43	43	43	37	43	43	43	43	37
SL 090P		65	60	50	50	65	40	65	65	60	60	50	50	65	50	60	50	50	40
SL 120		95	110	110	110	95	95	110	110	110	110	110	110	95	110	110	110	110	95
SL 120P		155	155	125	125	155	100	155	155	155	155	125	125	155	125	155	125	125	100

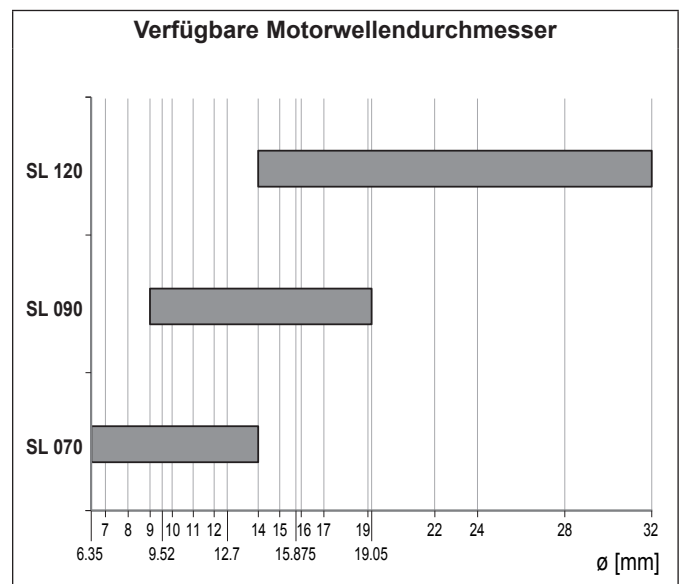
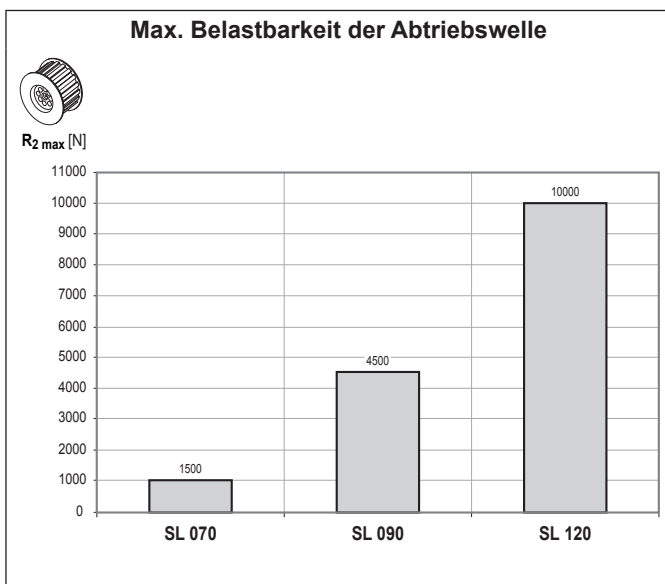

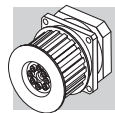

9.1 BESTELLBEZEICHNUNG

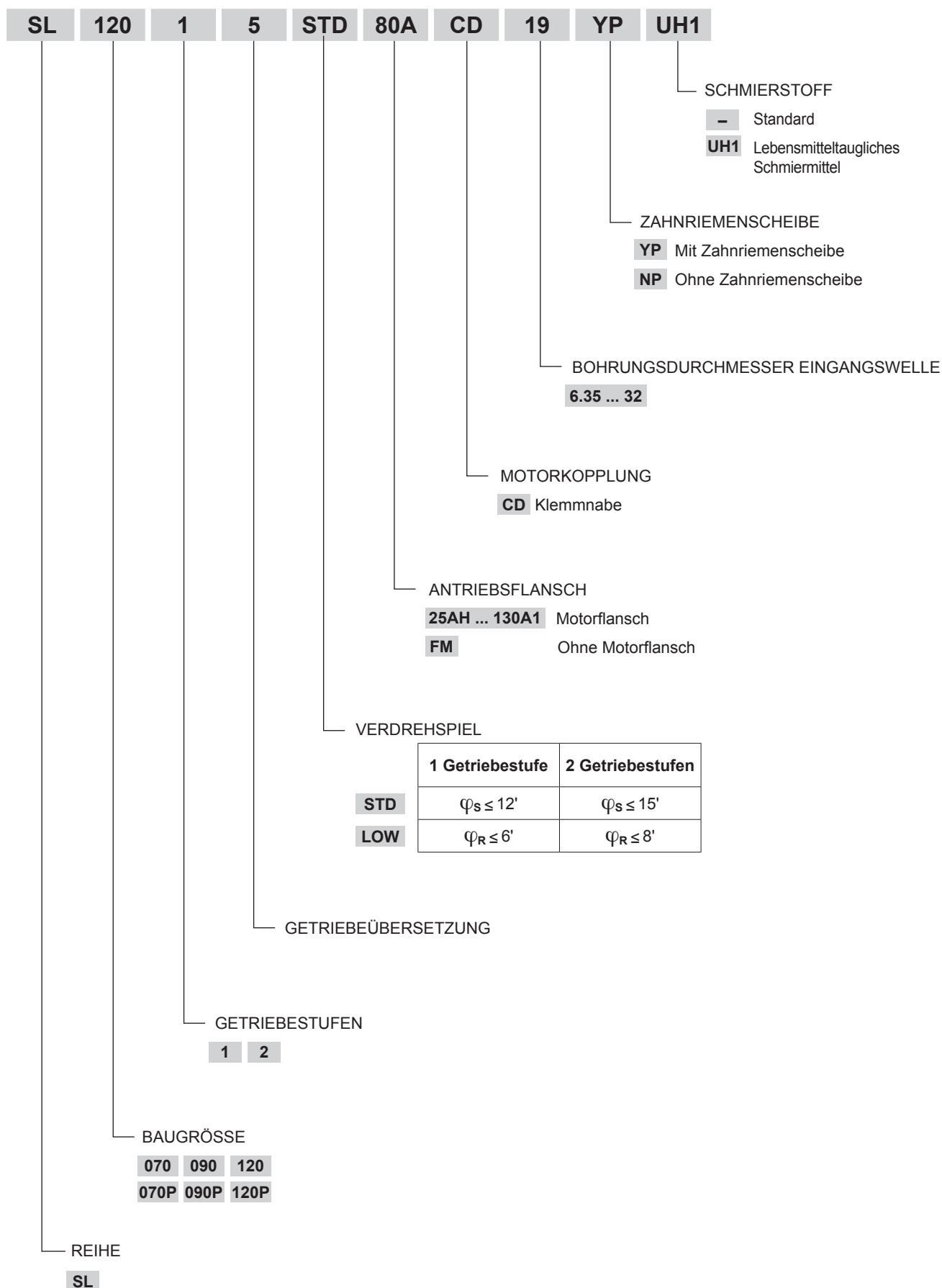

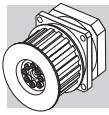

SL

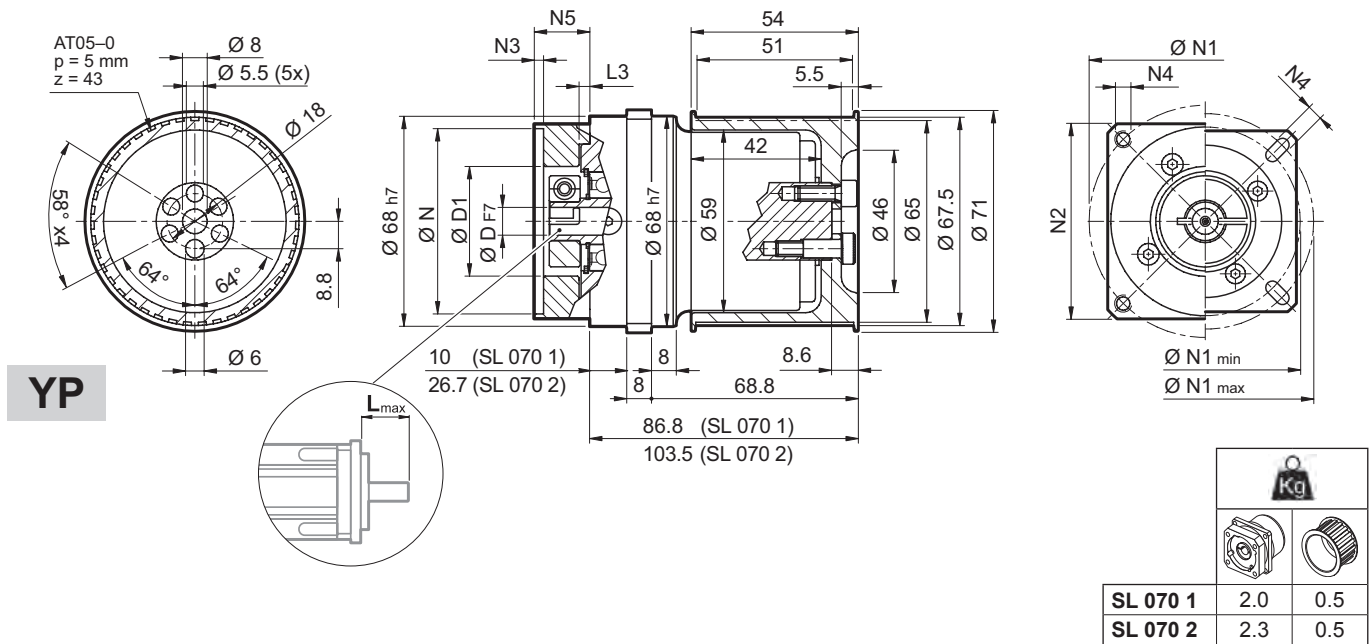

9.2 ABMESSUNGEN UND TECHNISCHE DATEN

SL 070



	D										N	N1		N2	N3	N4	N5	L _{max}
												min	max					
																		
25AH	6.35	7	8	9	9.52	-	-	-	-	-	25	39	56					
26AH	6.35	7	8	9	9.52	-	-	-	-	-	26	39	56					
28AH	6.35	7	8	9	9.52	-	-	-	-	-	28	39	56					
30AH	6.35	7	8	9	9.52	-	-	-	-	-	30	39	56					
32AH	6.35	7	8	9	9.52	-	-	-	-	-	32	39	56	65	3.5	4.5	25	25
34AH	6.35	7	8	9	9.52	-	-	-	-	-	34	40	56					
36AH	6.35	7	8	9	9.52	-	-	-	-	-	36	42	56					
39AH	6.35	7	8	9	9.52	-	-	-	-	-	39	45	56					
40AH	6.35	7	8	9	9.52	-	-	-	-	-	40	46	56					
38B	6.35	7	8	9	9.52	10	11	12	12.7	-	38.1	66.6	60	3	M4x10	18	25	
40B	6.35	7	8	9	9.52	10	11	12	12.7	-	40	63	60	3	M4x10	18	25	
50A	6.35	7	8	9	9.52	10	11	12	12.7	-	50	60	60	3	M4x10	18	25	
50B	6.35	7	8	9	9.52	10	11	12	12.7	14	50	65	60	3	M5x12	23	30	
50BH	6.35	7	8	9	9.52	10	11	12	12.7	14	50	65	65	3	5.5	25	32	
50C	6.35	7	8	9	9.52	10	11	12	12.7	14	50	70	60	3	M4x10	23	30	
55MH	6.35	7	8	9	9.52	10	11	12	12.7	-	55	80	65	2	5.5	16	23	
60A	6.35	7	8	9	9.52	10	11	12	12.7	-	60	75	65	3	M5x12	18	25	
60A1	6.35	7	8	9	9.52	10	11	12	12.7	14	60	75	65	3	M5x12	23	30	
60B	6.35	7	8	9	9.52	10	11	12	12.7	14	60	85	75	3	M5x12	23	30	
60C	6.35	7	8	9	9.52	10	11	12	12.7	14	60	90	75	3	M5x12	23	30	
70A	6.35	7	8	9	9.52	10	11	12	12.7	14	70	85	75	3	M6x15	23	30	
70B	6.35	7	8	9	9.52	10	11	12	12.7	14	70	90	75	3	M5x12	23	30	
73A	6.35	7	8	9	9.52	10	11	12	12.7	14	73	98.4	85	3	M5x12	25	32	
80A	6.35	7	8	9	9.52	10	11	12	12.7	14	80	100	85	3	M6x15	23	30	

Für weitere Motoradapter und Antriebswellenbohrungen bitte nachfragen.

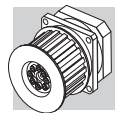

SL 070

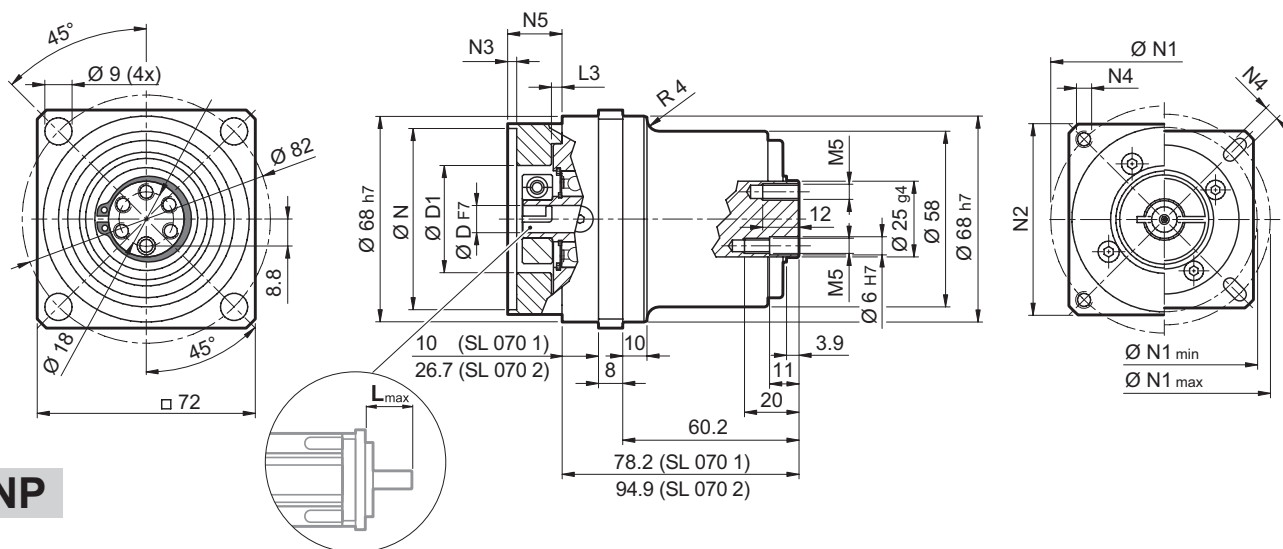

NP

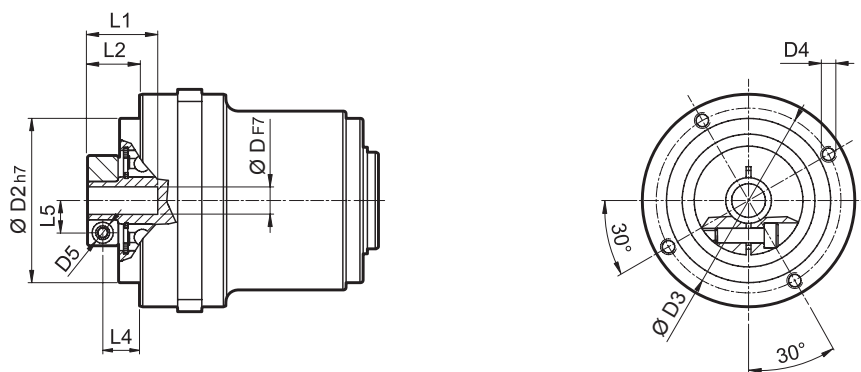

FM

D				D1	D2	D3	D4	D5	L1	L2	L3	L4	L5
6.35	7			32.5	50	42.5	M4x8	M4	21.7	13.2	3	8.2	8
8	9	9.52	10	32.5	50	42.5	M4x8	M4	21.7	13.2	3	8.2	9
11	12	12.7		35.5	50	42.5	M4x8	M4	22	13.5	3	8.5	11
14				35.5	50	42.5	M4x8	M4	25	17	3	10.2	11.5

i	M _{n2} [Nm]	M _{a2} [Nm]	M _{p2} [Nm]	n ₁ [min ⁻¹]	n _{1 max} [min ⁻¹]	φ _S [arcmin]	φ _R [arcmin]	C _t [$\frac{Nm}{arcmin}$]	R _{2 max} * [N]	A _{2 max} [N]	η %	J _G [kgcm ²]		3.86
												D		
SL 070 1_3	18	30	60	3300	4000	12'	6'	6.5	3500	1600	97	0.14	0.16	3.86
SL 070 1_4	25	35	70	3500	5000	12'	6'	6.5	3500	1600	97	0.09	0.11	
SL 070 1_5	25	35	70	3500	5000	12'	6'	6.5	3500	1600	97	0.07	0.09	
SL 070 1_7	25	35	70	3500	5000	12'	6'	6.5	3500	1600	97	0.05	0.07	
SL 070 1_10	18	30	60	4000	6000	12'	6'	6.5	3500	1600	97	0.04	0.06	
SL 070 2_9	18	30	60	3300	4000	15'	8'	6	3500	1600	94	0.11	0.13	
SL 070 2_12	25	35	70	3300	4000	15'	8'	6	3500	1600	94	0.10	0.13	
SL 070 2_15	25	35	70	3300	4000	15'	8'	6	3500	1600	94	0.10	0.12	
SL 070 2_16	25	35	70	3500	5000	15'	8'	6	3500	1600	94	0.07	0.09	
SL 070 2_20	25	35	70	3500	5000	15'	8'	6	3500	1600	94	0.06	0.08	
SL 070 2_25	25	35	70	3500	5000	15'	8'	6	3500	1600	94	0.06	0.08	
SL 070 2_28	25	35	70	4000	6000	15'	8'	6	3500	1600	94	0.05	0.07	
SL 070 2_30	18	30	60	4000	6000	15'	8'	6	3500	1600	94	0.04	0.06	
SL 070 2_35	25	35	70	4000	6000	15'	8'	6	3500	1600	94	0.05	0.07	
SL 070 2_40	25	35	70	4000	6000	15'	8'	6	3500	1600	94	0.04	0.06	
SL 070 2_50	25	35	70	4000	6000	15'	8'	6	3500	1600	94	0.04	0.06	
SL 070 2_70	25	35	70	4000	6000	15'	8'	6	3500	1600	94	0.04	0.06	
SL 070 2_100	18	30	60	4000	6000	15'	8'	6	3500	1600	94	0.04	0.06	

* Gilt für Zahnriemenanwendungen

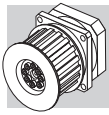

SL 090

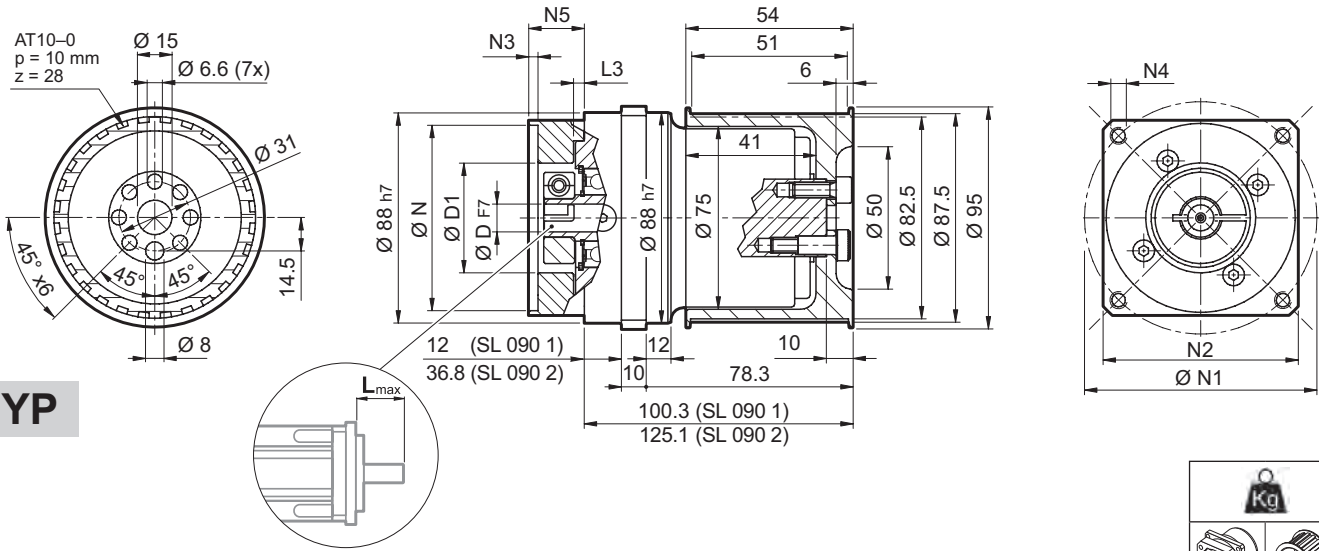

YP

SL 090 1	3.6	0.8
SL 090 2	4.7	0.8

												N	N1	N2	N3	N4	N5	L _{max}
40B1	9	9.52	11	12	12.7	14	-	-	-	-	-	40	63	80	4	M4x10	34	40
45A	9	9.52	11	12	12.7	-	-	-	-	-	-	45	63	80	4	M4x10	34	40
50B1	9	9.52	11	12	12.7	14	-	-	-	-	-	50	65	80	4	M5x16	34	40
50BH1	9	9.52	11	12	12.7	14	-	-	-	-	-	50	65	80	4	5.5	34	40
50C1	9	9.52	11	12	12.7	14	-	-	-	-	-	50	70	80	4	M4x10	34	40
50D	9	9.52	11	12	12.7	14	-	-	-	-	-	50	95	80	4	M6x10	34	40
55A	9	9.52	11	12	12.7	14	15.875	16	17	19	19.05	55.5	125.7	105	4	M6x16	34	40
60A2	9	9.52	11	12	12.7	14	-	-	-	-	-	60	75	80	4	M5x16	34	40
60AH2	9	9.52	11	12	12.7	14	-	-	-	-	-	60	75	90	4	5.5	34	40
60B1	9	9.52	11	12	12.7	14	15.875	16	-	-	-	60	85	80	4	M5x16	34	40
60C1	9	9.52	11	12	12.7	14	15.875	16	-	-	-	60	90	80	4	M5x16	34	40
70A1	9	9.52	11	12	12.7	14	15.875	16	17	19	19.05	70	85	80	4	M6x20	34	40
70AH1	9	9.52	11	12	12.7	14	15.875	16	17	19	19.05	70	85	90	4	6.5	34	40
70B1	9	9.52	11	12	12.7	14	15.875	16	17	19	19.05	70	90	80	4	M5x16	34	40
73A1	9	9.52	11	12	12.7	14	-	-	-	-	-	73	98.4	85	4	M5x16	34	40
80A1	9	9.52	11	12	12.7	14	15.875	16	17	19	19.05	80	100	90	4	M6x16	34	40
95A	9	9.52	11	12	12.7	14	15.875	16	17	19	19.05	95	115	100	4	M8x20	34	40
95B	9	9.52	11	12	12.7	14	15.875	16	17	19	19.05	95	130	115	4	M8x20	34	40
110A	9	9.52	11	12	12.7	14	15.875	16	17	19	19.05	110	130	115	4	M8x20	34	40
110B	9	9.52	11	12	12.7	14	15.875	16	17	19	19.05	110	145	120	6.5	M8x20	44	50
110B1	9	9.52	11	12	12.7	14	15.875	16	17	19	19.05	110	145	120	6.5	M8x20	54	60

Für weitere Motoradapter und Antriebswellenbohrungen bitte nachfragen.

SL

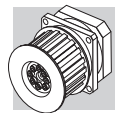

SL 090

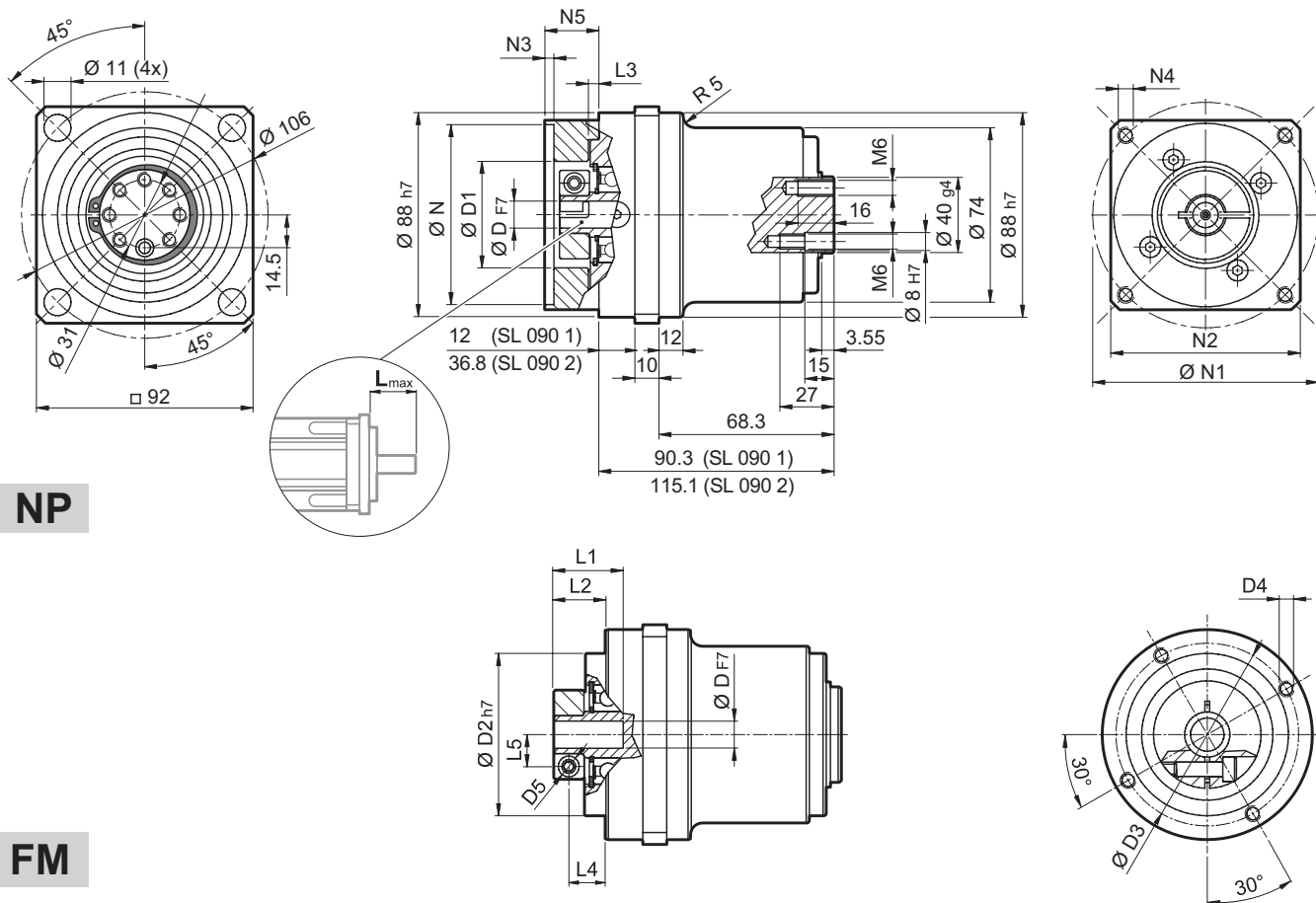

NP

FM

D		D1	D2	D3	D4	D5	L1	L2	L3	L4	L5
9	9.52	38	68	76.5	M6x10	M6	34	26.8	9.5	18.8	10.5
11	12	52	68	76.5	M6x10	M6	34	26.8	9.5	18.8	12.5
14	15.875	48	68	76.5	M6x10	M6	34	26.8	9.5	18.8	14.5
19	19.05	51	68	76.5	M6x10	M6	34	26.8	9.5	18.8	16.5

i	M _{n2} [Nm]	M _{a2} [Nm]	M _{p2} [Nm]	n ₁ [min ⁻¹]	n _{1 max} [min ⁻¹]	φ _S [arcmin]	φ _R [arcmin]	C _t [Nm/arcmin]	R _{2 max} * [N]	A _{2 max} [N]	η %	J _G [kgcm ²]		10.95
												D	D	
SL 090 1_3	37	70	150	2900	3500	12'	6'	12	4500	2000	97	0.72	0.81	10.95
SL 090 1_4	43	80	160	3100	4500	12'	6'	12	4500	2000	97	0.49	0.58	
SL 090 1_5	43	80	160	3200	4500	12'	6'	12	4500	2000	97	0.39	0.48	
SL 090 1_7	43	80	160	4000	6000	12'	6'	12	4500	2000	97	0.31	0.40	
SL 090 1_10	37	70	150	4000	6000	12'	6'	12	4500	2000	97	0.27	0.35	
SL 090 2_9	37	70	150	2900	3500	15'	8'	11.5	4500	2000	94	0.47	0.61	
SL 090 2_12	43	80	160	2900	3500	15'	8'	11.5	4500	2000	94	0.44	0.58	
SL 090 2_15	43	80	160	2900	3500	15'	8'	11.5	4500	2000	94	0.43	0.57	
SL 090 2_16	43	80	160	3100	4500	15'	8'	11.5	4500	2000	94	0.31	0.45	
SL 090 2_20	43	80	160	3200	4500	15'	8'	11.5	4500	2000	94	0.26	0.40	
SL 090 2_25	43	80	160	3200	4500	15'	8'	11.5	4500	2000	94	0.26	0.40	
SL 090 2_28	43	80	160	4000	6000	15'	8'	11.5	4500	2000	94	0.22	0.36	
SL 090 2_30	37	70	150	4000	6000	15'	8'	11.5	4500	2000	94	0.20	0.34	
SL 090 2_35	43	80	160	4000	6000	15'	8'	11.5	4500	2000	94	0.22	0.36	
SL 090 2_40	43	80	160	4000	6000	15'	8'	11.5	4500	2000	94	0.20	0.34	
SL 090 2_50	43	80	160	4000	6000	15'	8'	11.5	4500	2000	94	0.20	0.34	
SL 090 2_70	43	80	160	4000	6000	15'	8'	11.5	4500	2000	94	0.20	0.34	
SL 090 2_100	37	70	150	4000	6000	15'	8'	11.5	4500	2000	94	0.19	0.34	

* Gilt für Zahnriemenanwendungen

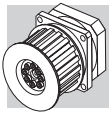

SL 120

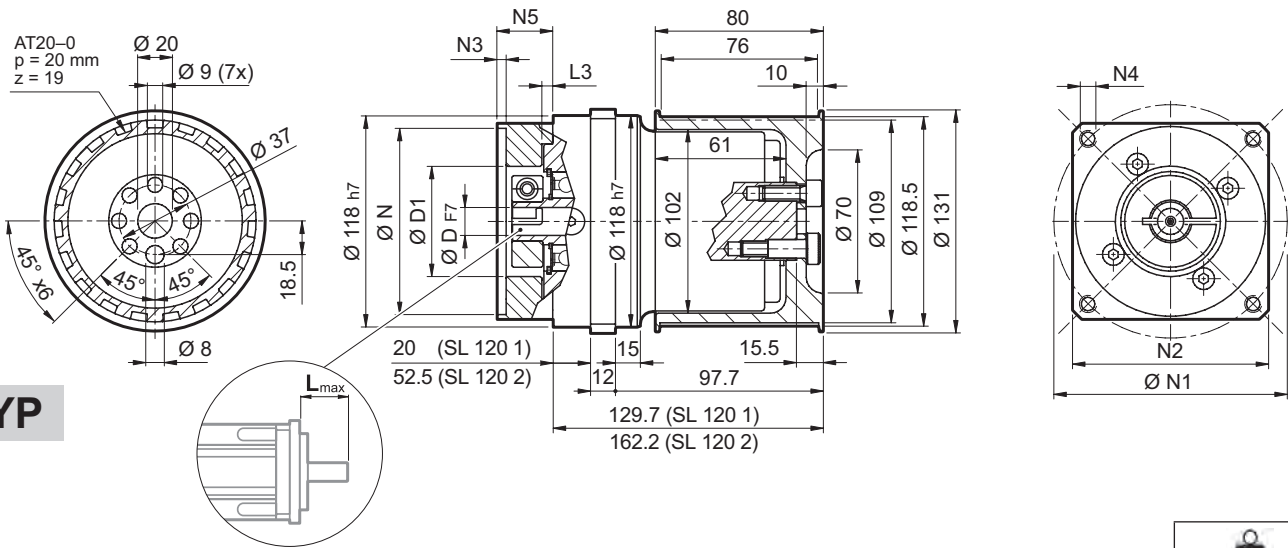

YP

	8.4	2.6
	10.9	2.6

SL 120 1	8.4	2.6
SL 120 2	10.9	2.6

SL

									N	N1	N2	N3	N4	N5	L _{max}	
50D	14	15	15.875	16	19	-	-	-	-	50	95	100	5	M6x14	28	40
55A	14	15	15.875	16	19	-	-	-	-	55.5	125.7	105	5	M6x16	28	40
60A2	14	15	15.875	16	19	-	-	-	-	60	75	100	5	M5x14	28	40
60AH2	14	15	15.875	16	19	-	-	-	-	60	75	100	5	6.5	33	40
60B1	14	15	15.875	16	19	-	-	-	-	60	85	100	6.5	M5x14	28	40
70A1	14	15	15.875	16	19	-	-	-	-	70	85	100	5	M6x14	28	40
70AH1	14	15	15.875	16	19	-	-	-	-	70	85	100	5	6	33	40
70B1	14	15	15.875	16	19	-	-	-	-	70	90	100	5	M5x12	28	40
80A1	14	15	15.875	16	19	-	-	-	-	80	100	100	5	M6x16	28	40
80AH1	14	15	15.875	16	19	-	-	-	-	80	100	100	5	6.5	28	40
95A	14	15	15.875	16	19	-	-	-	-	95	115	100	5	M8x18	28	40
95A1	14	15	15.875	16	19	22	24	-	-	95	115	100	5	M8x18	38	50
95B	14	15	15.875	16	19	-	-	-	-	95	130	115	5	M8x18	28	40
110A	14	15	15.875	16	19	-	-	-	-	110	130	115	5	M8x18	28	40
110A1	14	15	15.875	16	19	22	24	-	-	110	130	115	6.5	M8x20	38	50
110B	14	15	15.875	16	19	22	24	-	-	110	145	120	6.5	M8x20	38	50
110B1	14	15	15.875	16	19	22	24	28	-	110	145	120	6.5	M8x20	48	60
130A	14	15	15.875	16	19	22	24	-	-	130	165	140	6.5	M10x20	38	50
130A1	14	15	15.875	16	19	22	24	28	32	130	165	140	6.5	M10x25	48	60

Für weitere Motoradapter und Antriebswellenbohrungen bitte nachfragen.

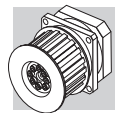

SL 120

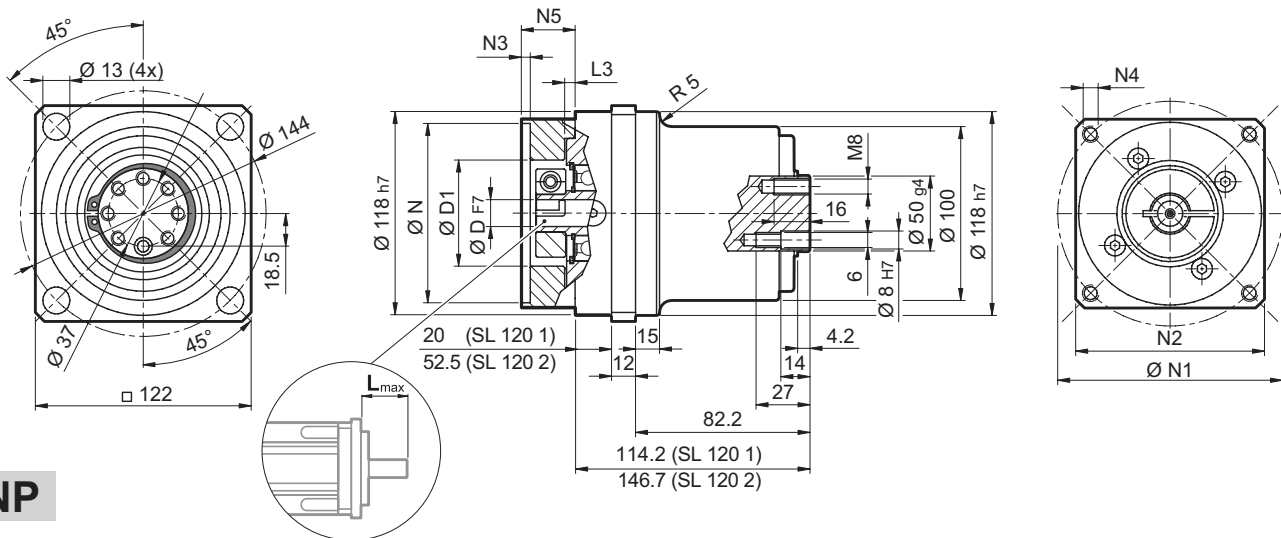

NP

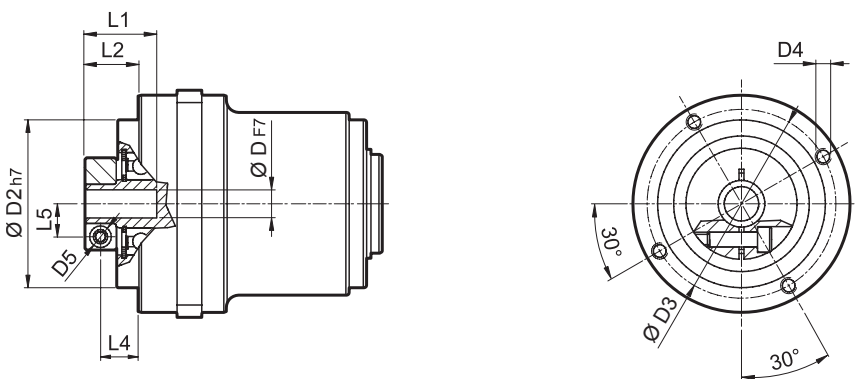

FM

				D1	D2	D3	D4	D5	L1	L2	L3	L4	L5
14	15	15.875	16	48	90	98	M6x15	M6	33.5	20	7.6	12.5	14.5
19				51	90	98	M6x15	M6	33.5	20	7.6	12.5	16.5
22	24			56.5	90	98	M6x15	M6	36.5	23	7.6	14	19
28				70	90	98	M6x15	M8	36.5	23	7.6	14	22.5
32				71	90	98	M6x15	M8	38	24.5	7.6	15.5	24.5

	i	M_{n2} [Nm]	M_{a2} [Nm]	M_{p2} [Nm]	n_1 [min ⁻¹]	n_{1max} [min ⁻¹]	φ_s [arcmin]	φ_R [arcmin]	C_t [Nm/arcmin]	R_{2max}^* [N]	A_{2max} [N]	η %	J_G [kgcm ²]			
														14 ... 19	22 ; 24	
SL 120 1_3		95	160	300	2500	3500	12'	6'	45	10000	4500	97	2.18	2.81	3.25	50.62
SL 120 1_4		110	190	360	2800	4500	12'	6'	45	10000	4500	97	1.30	1.93	2.37	
SL 120 1_5		110	190	360	3000	4500	12'	6'	45	10000	4500	97	0.96	1.59	2.03	
SL 120 1_7		110	190	360	3500	4500	12'	6'	45	10000	4500	97	0.66	1.28	1.72	
SL 120 1_10		95	160	300	3500	5000	12'	6'	45	10000	4500	97	0.49	1.11	1.55	
SL 120 2_9		95	160	300	2500	3500	15'	8'	40	10000	4500	94	1.61	2.20	2.57	
SL 120 2_12		110	190	360	2500	3500	15'	8'	40	10000	4500	94	1.51	2.10	2.47	
SL 120 2_15		110	190	360	2500	3500	15'	8'	40	10000	4500	94	1.47	2.06	2.43	
SL 120 2_16		110	190	360	2800	4500	15'	8'	40	10000	4500	94	0.92	1.52	1.88	
SL 120 2_20		110	190	360	3000	4500	15'	8'	40	10000	4500	94	0.90	1.50	1.86	
SL 120 2_25		110	190	360	3000	4500	15'	8'	40	10000	4500	94	0.71	1.30	1.67	
SL 120 2_28		110	190	360	3500	5000	15'	8'	40	10000	4500	94	0.54	1.13	1.50	
SL 120 2_30		95	160	300	3500	5000	15'	8'	40	10000	4500	94	0.44	1.04	1.40	
SL 120 2_35		110	190	360	3500	5000	15'	8'	40	10000	4500	94	0.53	1.13	1.49	
SL 120 2_40		110	190	360	3500	5000	15'	8'	40	10000	4500	94	0.43	1.03	1.39	
SL 120 2_50		110	190	360	3500	5000	15'	8'	40	10000	4500	94	0.43	1.02	1.39	
SL 120 2_70		110	190	360	3500	5000	15'	8'	40	10000	4500	94	0.42	1.02	1.38	
SL 120 2_100		95	160	300	3500	5000	15'	8'	40	10000	4500	94	0.42	1.02	1.38	

* Gilt für Zahnriemenanwendungen

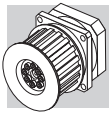

SL 070P

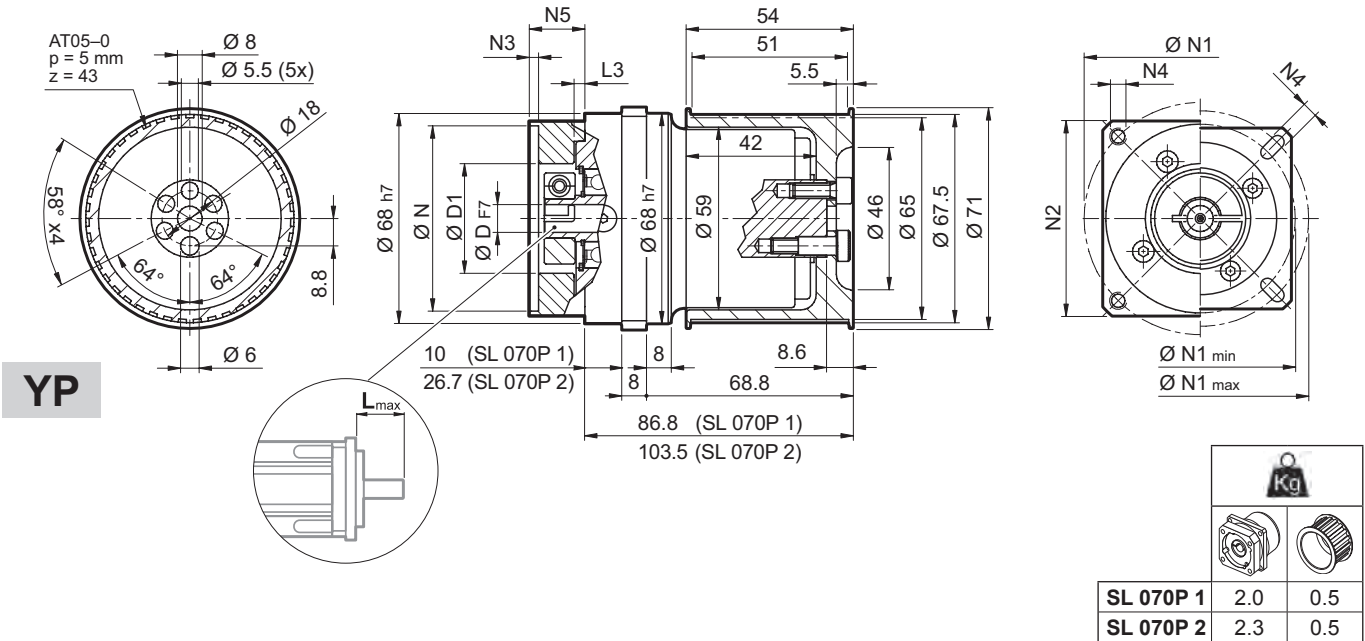

		D											N	N1		N2	N3	N4	N5	L _{max}
															min					
25AH	6.35	7	8	9	9.52	-	-	-	-	-	25	39	56							
26AH	6.35	7	8	9	9.52	-	-	-	-	-	26	39	56							
28AH	6.35	7	8	9	9.52	-	-	-	-	-	28	39	56							
30AH	6.35	7	8	9	9.52	-	-	-	-	-	30	39	56							
32AH	6.35	7	8	9	9.52	-	-	-	-	-	32	39	56	65	3.5	4.5	25	25		
34AH	6.35	7	8	9	9.52	-	-	-	-	-	34	40	56							
36AH	6.35	7	8	9	9.52	-	-	-	-	-	36	42	56							
39AH	6.35	7	8	9	9.52	-	-	-	-	-	39	45	56							
40AH	6.35	7	8	9	9.52	-	-	-	-	-	40	46	56							
38B	6.35	7	8	9	9.52	10	11	12	12.7	-	38.1	66.6	60	3	M4x10	18	25			
40B	6.35	7	8	9	9.52	10	11	12	12.7	-	40	63	60	3	M4x10	18	25			
50A	6.35	7	8	9	9.52	10	11	12	12.7	-	50	60	60	3	M4x10	18	25			
50B	6.35	7	8	9	9.52	10	11	12	12.7	14	50	65	60	3	M5x12	23	30			
50BH	6.35	7	8	9	9.52	10	11	12	12.7	14	50	65	65	3	5.5	25	32			
50C	6.35	7	8	9	9.52	10	11	12	12.7	14	50	70	60	3	M4x10	23	30			
55MH	6.35	7	8	9	9.52	10	11	12	12.7	-	55	80	65	2	5.5	16	23			
60A	6.35	7	8	9	9.52	10	11	12	12.7	-	60	75	65	3	M5x12	18	25			
60A1	6.35	7	8	9	9.52	10	11	12	12.7	14	60	75	65	3	M5x12	23	30			
60B	6.35	7	8	9	9.52	10	11	12	12.7	14	60	85	75	3	M5x12	23	30			
60C	6.35	7	8	9	9.52	10	11	12	12.7	14	60	90	75	3	M5x12	23	30			
70A	6.35	7	8	9	9.52	10	11	12	12.7	14	70	85	75	3	M6x15	23	30			
70B	6.35	7	8	9	9.52	10	11	12	12.7	14	70	90	75	3	M5x12	23	30			
73A	6.35	7	8	9	9.52	10	11	12	12.7	14	73	98.4	85	3	M5x12	25	32			
80A	6.35	7	8	9	9.52	10	11	12	12.7	14	80	100	85	3	M6x15	23	30			

Für weitere Motoradapter und Antriebswellenbohrungen bitte nachfragen.

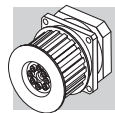

SL 070P

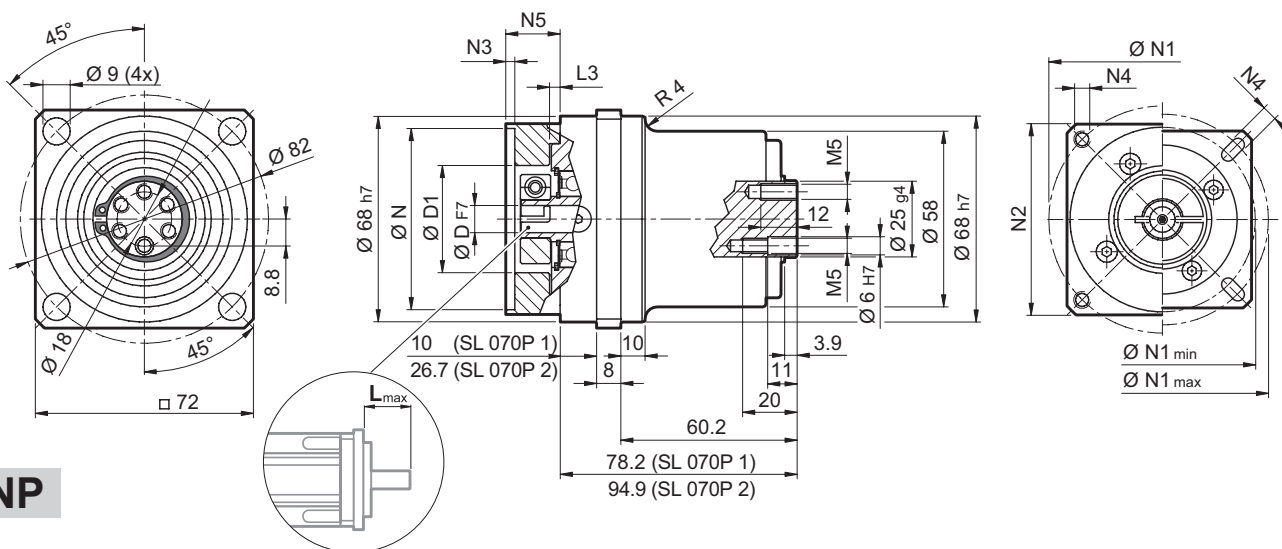

NP

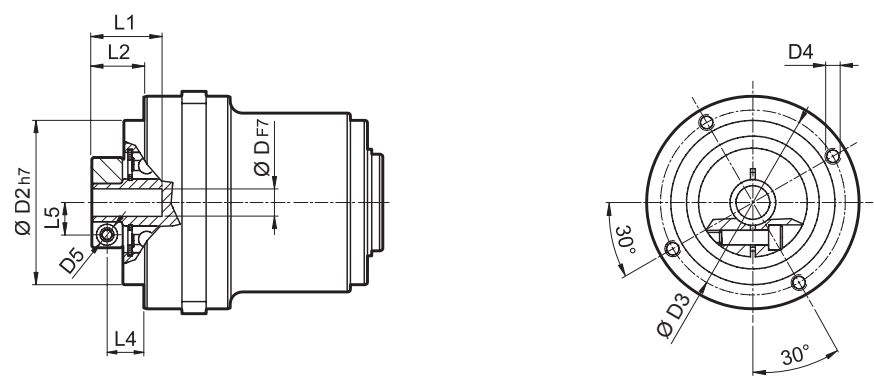

FM

				D1	D2	D3	D4	D5	L1	L2	L3	L4	L5
6.35	7			32.5	50	42.5	M4x8	M4	21.7	13.2	3	8.2	8
8	9	9.52	10	32.5	50	42.5	M4x8	M4	21.7	13.2	3	8.2	9
11	12	12.7		35.5	50	42.5	M4x8	M4	22	13.5	3	8.5	11
14				35.5	50	42.5	M4x8	M4	25	17	3	10.2	11.5

	i	M_{n2} [Nm]	M_{a2} [Nm]	M_{p2} [Nm]	n_1 [min ⁻¹]	$n_{1 max}$ [min ⁻¹]	φ_S [arcmin]	φ_R [arcmin]	C_t [Nm/arcmin]	$R_{2 max}^*$ [N]	$A_{2 max}$ [N]	η %	J_G [kgcm ²]		
													D	6 ... 9.52	
SL 070P 1_3		29	55	60	3300	4000	12'	6'	6.5	3500	1600	97	0.14	0.16	3.86
SL 070P 1_4		30	45	70	3500	5000	12'	6'	6.5	3500	1600	97	0.09	0.11	
SL 070P 1_5		25	40	70	3500	5000	12'	6'	6.5	3500	1600	97	0.07	0.09	
SL 070P 1_7		25	40	70	4000	5000	12'	6'	6.5	3500	1600	97	0.05	0.07	
SL 070P 1_10		18	30	60	4000	6000	12'	6'	6.5	3500	1600	97	0.04	0.06	
SL 070P 2_9		29	55	60	3300	4000	15'	8'	6	3500	1600	94	0.11	0.13	
SL 070P 2_12		29	55	70	3300	4000	15'	8'	6	3500	1600	94	0.10	0.13	
SL 070P 2_15		29	55	70	3300	4000	15'	8'	6	3500	1600	94	0.10	0.12	
SL 070P 2_16		30	45	70	3500	5000	15'	8'	6	3500	1600	94	0.07	0.09	
SL 070P 2_20		30	45	70	3500	5000	15'	8'	6	3500	1600	94	0.06	0.08	
SL 070P 2_25		30	45	70	3500	5000	15'	8'	6	3500	1600	94	0.06	0.08	
SL 070P 2_28		30	45	70	4000	6000	15'	8'	6	3500	1600	94	0.05	0.07	
SL 070P 2_30		29	55	60	4000	6000	15'	8'	6	3500	1600	94	0.04	0.06	
SL 070P 2_35		30	45	70	4000	6000	15'	8'	6	3500	1600	94	0.05	0.07	
SL 070P 2_40		30	45	70	4000	6000	15'	8'	6	3500	1600	94	0.04	0.06	
SL 070P 2_50		30	45	70	4000	6000	15'	8'	6	3500	1600	94	0.04	0.06	
SL 070P 2_70		30	45	70	4000	6000	15'	8'	6	3500	1600	94	0.04	0.06	
SL 070P 2_100		18	30	60	4000	6000	15'	8'	6	3500	1600	94	0.04	0.06	

* Gilt für Zahnriemenanwendungen

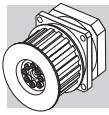

SL 090P

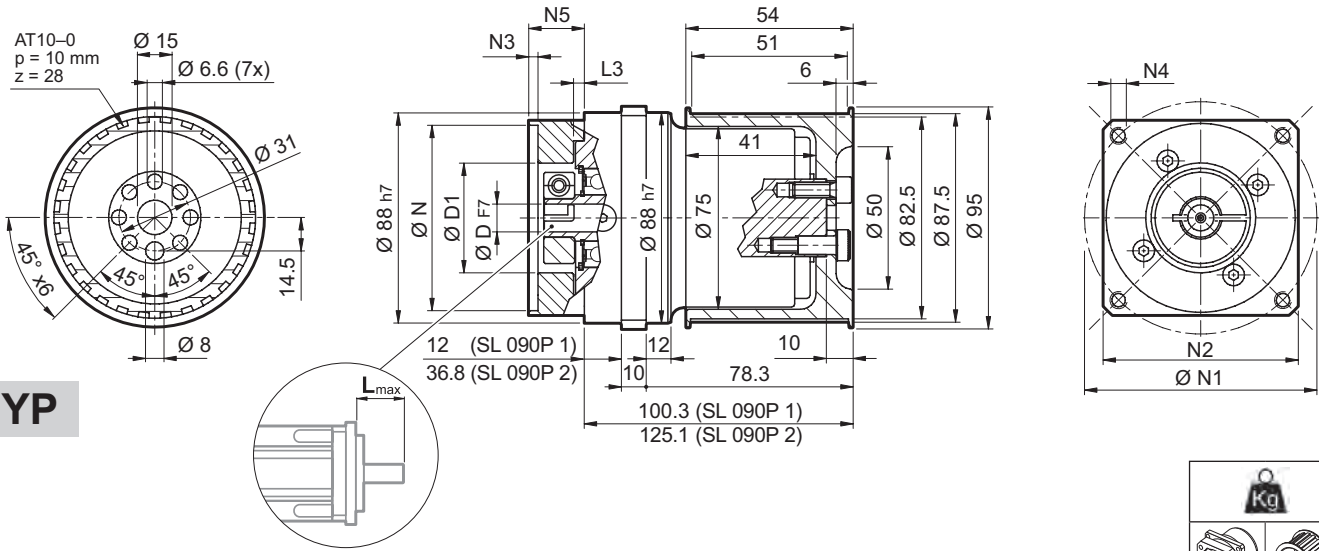

SL 090P 1	3.6	0.8
SL 090P 2	4.7	0.8

												N	N1	N2	N3	N4	N5	L_{max}
40B1	9	9.52	11	12	12.7	14	-	-	-	-	-	40	63	80	4	M4x10	34	40
45A	9	9.52	11	12	12.7	-	-	-	-	-	-	45	63	80	4	M4x10	34	40
50B1	9	9.52	11	12	12.7	14	-	-	-	-	-	50	65	80	4	M5x16	34	40
50BH1	9	9.52	11	12	12.7	14	-	-	-	-	-	50	65	80	4	5.5	34	40
50C1	9	9.52	11	12	12.7	14	-	-	-	-	-	50	70	80	4	M4x10	34	40
50D	9	9.52	11	12	12.7	14	-	-	-	-	-	50	95	80	4	M6x10	34	40
55A	9	9.52	11	12	12.7	14	15.875	16	17	19	19.05	55.5	125.7	105	4	M6x16	34	40
60A2	9	9.52	11	12	12.7	14	-	-	-	-	-	60	75	80	4	M5x16	34	40
60AH2	9	9.52	11	12	12.7	14	-	-	-	-	-	60	75	90	4	5.5	34	40
60B1	9	9.52	11	12	12.7	14	15.875	16	-	-	-	60	85	80	4	M5x16	34	40
60C1	9	9.52	11	12	12.7	14	15.875	16	-	-	-	60	90	80	4	M5x16	34	40
70A1	9	9.52	11	12	12.7	14	15.875	16	17	19	19.05	70	85	80	4	M6x20	34	40
70AH1	9	9.52	11	12	12.7	14	15.875	16	17	19	19.05	70	85	90	4	6.5	34	40
70B1	9	9.52	11	12	12.7	14	15.875	16	17	19	19.05	70	90	80	4	M5x16	34	40
73A1	9	9.52	11	12	12.7	14	-	-	-	-	-	73	98.4	85	4	M5x16	34	40
80A1	9	9.52	11	12	12.7	14	15.875	16	17	19	19.05	80	100	90	4	M6x16	34	40
95A	9	9.52	11	12	12.7	14	15.875	16	17	19	19.05	95	115	100	4	M8x20	34	40
95B	9	9.52	11	12	12.7	14	15.875	16	17	19	19.05	95	130	115	4	M8x20	34	40
110A	9	9.52	11	12	12.7	14	15.875	16	17	19	19.05	110	130	115	4	M8x20	34	40
110B	9	9.52	11	12	12.7	14	15.875	16	17	19	19.05	110	145	120	6.5	M8x20	44	50
110B1	9	9.52	11	12	12.7	14	15.875	16	17	19	19.05	110	145	120	6.5	M8x20	54	60

Für weitere Motoradapter und Antriebswellenbohrungen bitte nachfragen.

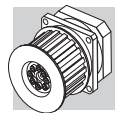

SL 090P

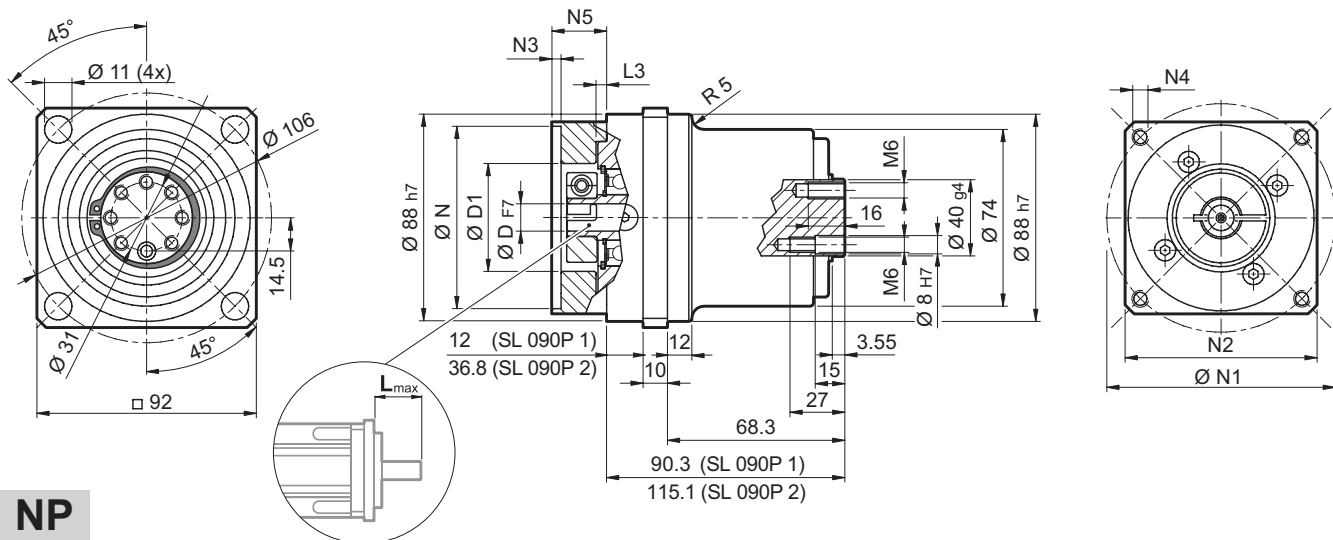

NP

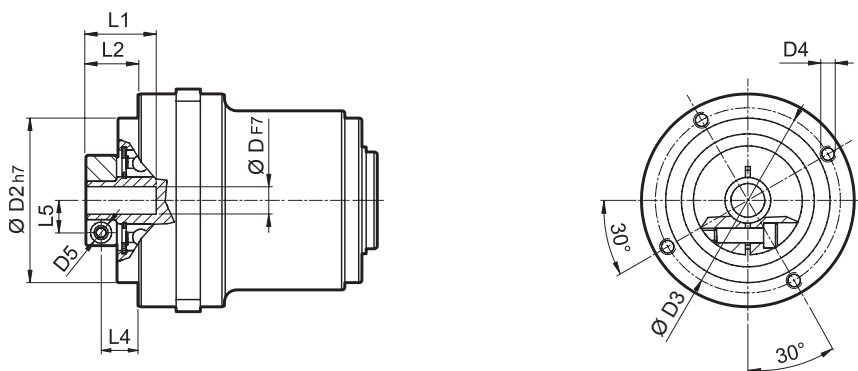

FM

D		D1	D2	D3	D4	D5	L1	L2	L3	L4	L5
9	9.52	38	68	76.5	M6x10	M6	34	26.8	9.5	18.8	10.5
11	12	52	68	76.5	M6x10	M6	34	26.8	9.5	18.8	12.5
14	15.875	48	68	76.5	M6x10	M6	34	26.8	9.5	18.8	14.5
19	19.05	51	68	76.5	M6x10	M6	34	26.8	9.5	18.8	16.5

i	M _{n2} [Nm]	M _{a2} [Nm]	M _{p2} [Nm]	n ₁ [min ⁻¹]	n _{1 max} [min ⁻¹]	φ _S [arcmin]	φ _R [arcmin]	C _t [Nm/arcmin]	R _{2 max} * [N]	A _{2 max} [N]	η %	J _G [kgcm ²]	
												D	
SL 090P 1_3	65	120	150	3500	4000	12'	6'	12	4500	2000	97	0.72	0.81
SL 090P 1_4	60	110	160	3500	4000	12'	6'	12	4500	2000	97	0.49	0.58
SL 090P 1_5	50	100	160	3200	4500	12'	6'	12	4500	2000	97	0.39	0.48
SL 090P 1_7	50	100	160	4000	6000	12'	6'	12	4500	2000	97	0.31	0.40
SL 090P 1_10	40	70	150	4000	6000	12'	6'	12	4500	2000	97	0.27	0.35
SL 090P 2_9	65	120	150	3500	4000	15'	8'	11.5	4500	2000	94	0.47	0.61
SL 090P 2_12	65	120	160	3500	4000	15'	8'	11.5	4500	2000	94	0.44	0.58
SL 090P 2_15	65	120	160	3500	4000	15'	8'	11.5	4500	2000	94	0.43	0.57
SL 090P 2_16	60	110	160	3500	4500	15'	8'	11.5	4500	2000	94	0.31	0.45
SL 090P 2_20	60	110	160	3500	4500	15'	8'	11.5	4500	2000	94	0.26	0.40
SL 090P 2_25	50	100	160	3200	4500	15'	8'	11.5	4500	2000	94	0.26	0.40
SL 090P 2_28	50	100	160	4000	6000	15'	8'	11.5	4500	2000	94	0.22	0.36
SL 090P 2_30	65	120	150	4000	6000	15'	8'	11.5	4500	2000	94	0.20	0.34
SL 090P 2_35	50	100	160	4000	6000	15'	8'	11.5	4500	2000	94	0.22	0.36
SL 090P 2_40	60	110	160	4000	6000	15'	8'	11.5	4500	2000	94	0.20	0.34
SL 090P 2_50	50	100	160	4000	6000	15'	8'	11.5	4500	2000	94	0.20	0.34
SL 090P 2_70	50	100	160	4000	6000	15'	8'	11.5	4500	2000	94	0.20	0.34
SL 090P 2_100	40	70	150	4000	6000	15'	8'	11.5	4500	2000	94	0.19	0.34

* Gilt für Zahnriemenanwendungen

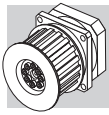

SL 120P

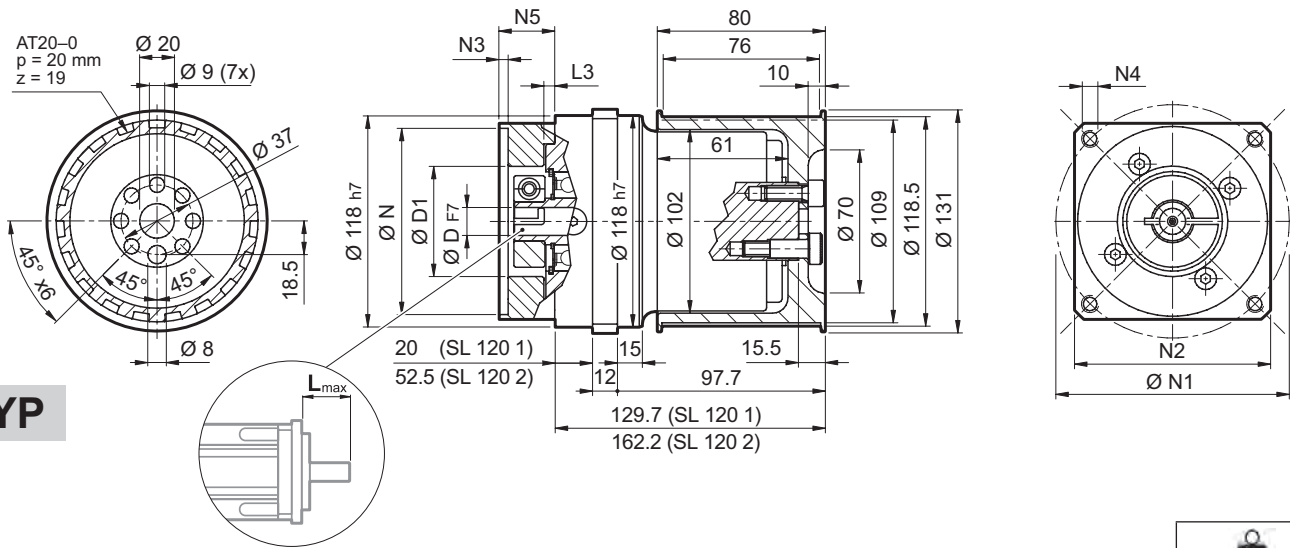

	8.4	2.6
	10.9	2.6

									N	N1	N2	N3	N4	N5	L _{max}	
50D	14	15	15.875	16	19	-	-	-	-	50	95	100	5	M6x14	28	40
55A	14	15	15.875	16	19	-	-	-	-	55.5	125.7	105	5	M6x16	28	40
60A2	14	15	15.875	16	19	-	-	-	-	60	75	100	5	M5x14	28	40
60AH2	14	15	15.875	16	19	-	-	-	-	60	75	100	5	6.5	33	40
60B1	14	15	15.875	16	19	-	-	-	-	60	85	100	6.5	M5x14	28	40
70A1	14	15	15.875	16	19	-	-	-	-	70	85	100	5	M6x14	28	40
70AH1	14	15	15.875	16	19	-	-	-	-	70	85	100	5	6	33	40
70B1	14	15	15.875	16	19	-	-	-	-	70	90	100	5	M5x12	28	40
80A1	14	15	15.875	16	19	-	-	-	-	80	100	100	5	M6x16	28	40
80AH1	14	15	15.875	16	19	-	-	-	-	80	100	100	5	6.5	28	40
95A	14	15	15.875	16	19	-	-	-	-	95	115	100	5	M8x18	28	40
95A1	14	15	15.875	16	19	22	24	-	-	95	115	100	5	M8x18	38	50
95B	14	15	15.875	16	19	-	-	-	-	95	130	115	5	M8x18	28	40
110A	14	15	15.875	16	19	-	-	-	-	110	130	115	5	M8x18	28	40
110A1	14	15	15.875	16	19	22	24	-	-	110	130	115	6.5	M8x20	38	50
110B	14	15	15.875	16	19	22	24	-	-	110	145	120	6.5	M8x20	38	50
110B1	14	15	15.875	16	19	22	24	28	-	110	145	120	6.5	M8x20	48	60
130A	14	15	15.875	16	19	22	24	-	-	130	165	140	6.5	M10x20	38	50
130A1	14	15	15.875	16	19	22	24	28	32	130	165	140	6.5	M10x25	48	60

Für weitere Motoradapter und Antriebswellenbohrungen bitte nachfragen.

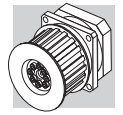

SL 120P

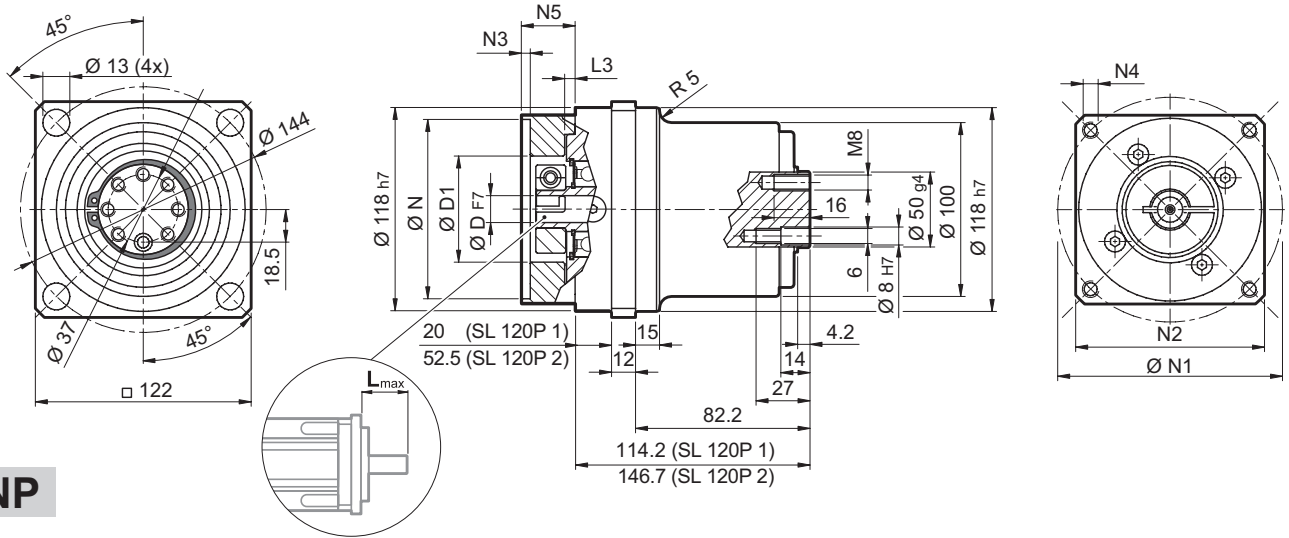

NP

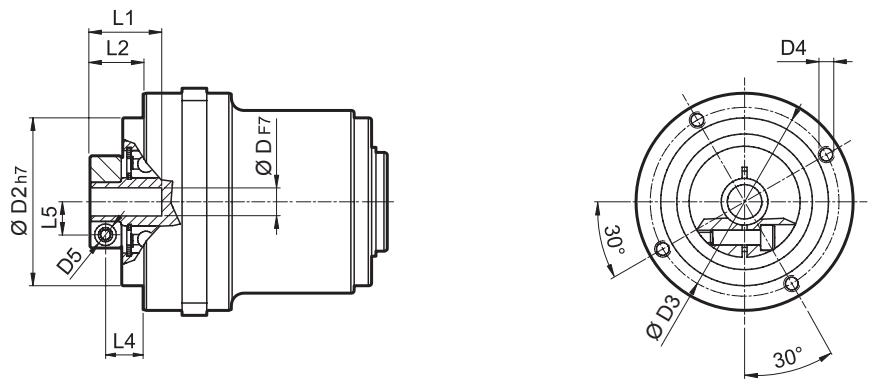

FM

				D1	D2	D3	D4	D5	L1	L2	L3	L4	L5
14	15	15.875	16	48	90	98	M6x15	M6	33.5	20	7.6	12.5	14.5
19				51	90	98	M6x15	M6	33.5	20	7.6	12.5	16.5
22	24			56.5	90	98	M6x15	M6	36.5	23	7.6	14	19
28				70	90	98	M6x15	M8	36.5	23	7.6	14	22.5
32				71	90	98	M6x15	M8	38	24.5	7.6	15.5	24.5

	M_{n2}	M_{a2}	M_{p2}	n_1	n_{1max}	φ_s	φ_R	C_t	R_{2max}^*	A_{2max}	η	J_G [kgcm ²]			
												D	14 ... 19	22 ; 24	
SL 120P 1_3	155	280	300	3000	4000	12'	6'	45	10000	4500	97	2.18	2.81	3.25	50.62
SL 120P 1_4	155	300	360	3000	4500	12'	6'	45	10000	4500	97	1.30	1.93	2.37	
SL 120P 1_5	125	240	360	3000	4500	12'	6'	45	10000	4500	97	0.96	1.59	2.03	
SL 120P 1_7	125	240	360	3500	4500	12'	6'	45	10000	4500	97	0.66	1.28	1.72	
SL 120P 1_10	100	160	300	3500	5000	12'	6'	45	10000	4500	97	0.49	1.11	1.55	
SL 120P 2_9	155	280	300	3000	4000	15'	8'	40	10000	4500	94	1.61	2.20	2.57	
SL 120P 2_12	155	300	360	3000	4000	15'	8'	40	10000	4500	94	1.51	2.10	2.47	
SL 120P 2_15	155	300	360	3000	4000	15'	8'	40	10000	4500	94	1.47	2.06	2.43	
SL 120P 2_16	155	300	360	3000	4500	15'	8'	40	10000	4500	94	0.92	1.52	1.88	
SL 120P 2_20	155	300	360	3000	4500	15'	8'	40	10000	4500	94	0.90	1.50	1.86	
SL 120P 2_25	125	240	360	3000	4500	15'	8'	40	10000	4500	94	0.71	1.30	1.67	
SL 120P 2_28	125	240	360	3500	5000	15'	8'	40	10000	4500	94	0.54	1.13	1.50	
SL 120P 2_30	155	300	300	3500	5000	15'	8'	40	10000	4500	94	0.44	1.04	1.40	
SL 120P 2_35	125	240	360	3500	5000	15'	8'	40	10000	4500	94	0.53	1.13	1.49	
SL 120P 2_40	155	300	360	3500	5000	15'	8'	40	10000	4500	94	0.43	1.03	1.39	
SL 120P 2_50	125	240	360	3500	5000	15'	8'	40	10000	4500	94	0.43	1.02	1.39	
SL 120P 2_70	125	240	360	3500	5000	15'	8'	40	10000	4500	94	0.42	1.02	1.38	
SL 120P 2_100	100	160	300	3500	5000	15'	8'	40	10000	4500	94	0.42	1.02	1.38	

* Gilt für Zahnriemenanwendungen

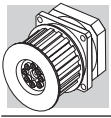

TS

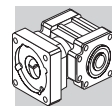

KR PRÄZISIONSKEGELRADGETRIEBE

Die flexible, effiziente und wirtschaftliche Lösung für Anwendungen, die platzsparende Winkelgetriebe mit minimalem Spiel erfordern.

Erhältlich in verschiedenen Ausführungen mit zahlreichen An- und Abtriebskonfigurationen.

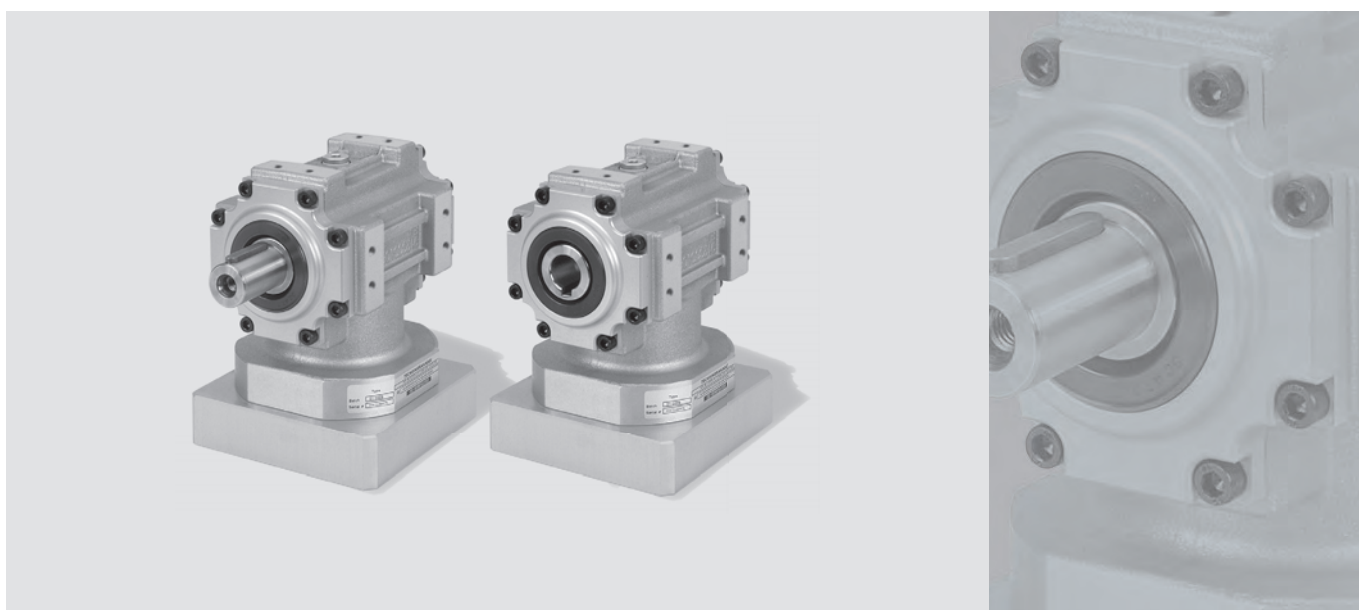

Produktmerkmale:

- Optimale Kombination von Dynamik, Kompaktheit und Präzision
- Entwickelt für Zyklus- und Dauerbetrieb
- Gute Verdrehsteifigkeit
- Niedriges Verdrehflankenspiel – unter 8 arcmin

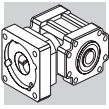

10 MERKMALE DER KR-REIHE

Die Präzisionskegelradgetriebe der KR-Reihe werden nach den strengsten Qualitätskriterien gefertigt und sind für Anwendungen konzipiert, deren Dynamik- und Präzisionsanforderungen geringes Gewicht und kompakte Abmaße verlangen.

Der Reihe enthält zahlreiche Optionen, Motoradapter und Abtriebswellenkonfigurationen, um die Installation in der angetriebenen Vorrichtung zu ermöglichen.

- Erhältlich mit Flankenspiel ($\psi_s \leq 8'$)
- Übersetzung $i = 1, 2, 5$
- Radialkugellager (SB) als Standard; optional können Kegelrollenlager (HB) für besonders anspruchsvolle Belastungsbedingungen ausgewählt werden
- Schutzart IP65
- Serienmäßige Fluorelastomer-Wellendichtungen
- Schalldruckpegel $L_P \leq 70$ dB(A). Gemessen in 1 m Abstand ohne Last und bei einer Eingangs Drehzahl von $n_1 = 3000 \text{ min}^{-1}$
- Schmierung optimiert für die gewünschte Betriebsart.

Ohne Verunreinigung muss das Schmiermittel nicht regelmäßig gewechselt werden.

Betrieb	KR 010 ... KR 040
S1 (kontinuierlich)	Synthetiköl Viskositätsklasse ISO VG 220
S5 (unterbrochen)	NLGI Fettkonsistenz 00

- Umgebungstemperatur min. -20°C , max. $+30^\circ\text{C}$; bei Temperaturen höher als 30°C ist der Temperaturfaktor f_T zu berücksichtigen.
- Die Gehäusetemperatur darf $T_{\text{max}} = 90^\circ\text{C}$ nicht übersteigen.

Übersicht der Nenndrehmomente		M_{n2} [Nm]		
[i]	1	2	5	
KR 010	10	7	3	
KR 020	24	15	10	
KR 030	55	37	22	
KR 040	120	85	45	

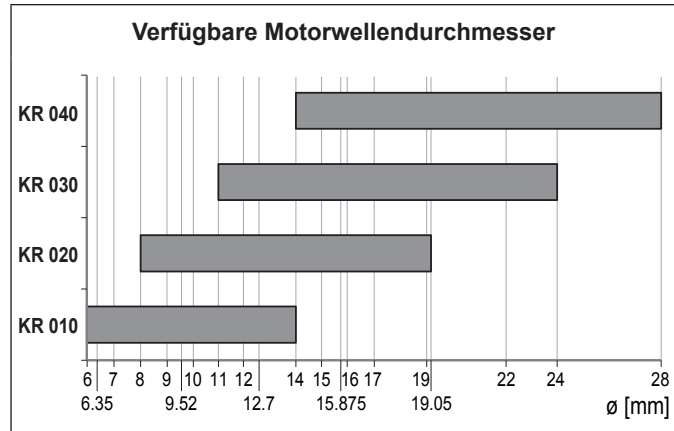

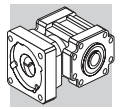

10.1 VERSIONEN

Vollwelle

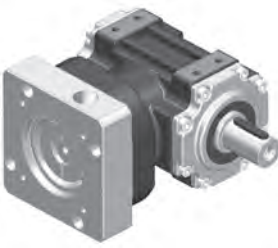
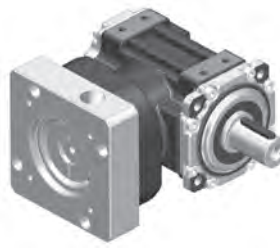
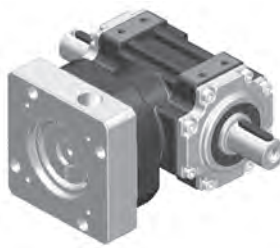
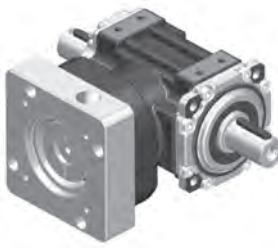
LP	LPF	LD	LDF
			
Einfache Abtriebswelle	Einfache Abtriebswelle + Flansch	Doppelte Abtriebswelle	Doppelte Abtriebswelle + Flansch

Hohlwelle

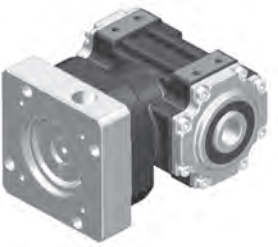
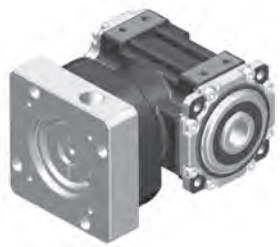
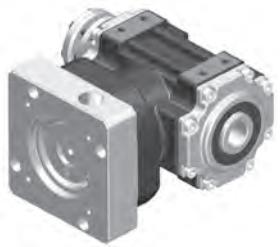
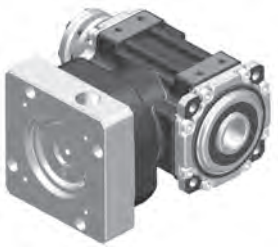
H	HF	S	SF
			
Passfedernut (KR 030...KR 040)	Passfedernut + Flansch (KR 030...KR 040)	Schrumpfscheibe	Schrumpfscheibe + Flansch

10.2 MONTAGEPOSITIONEN

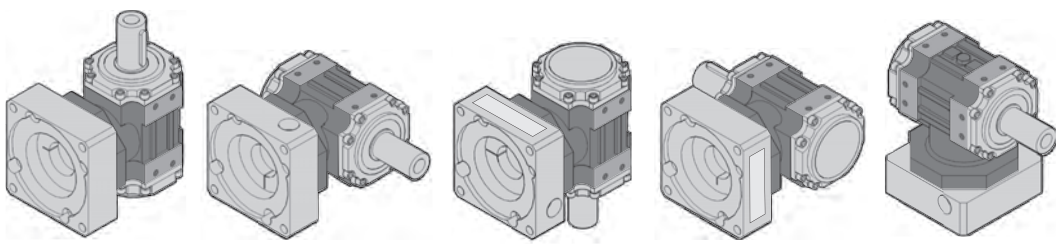
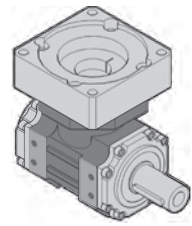
U	VA
	

10.3 WELLENDREHRICHTUNG

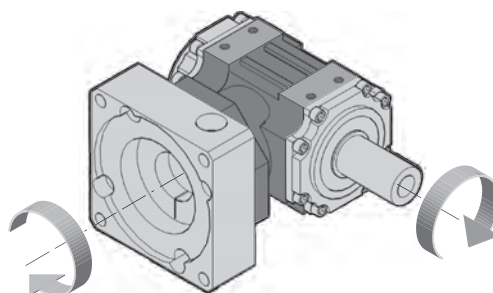

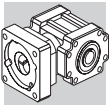

10.4 BESTELLBEZEICHNUNG

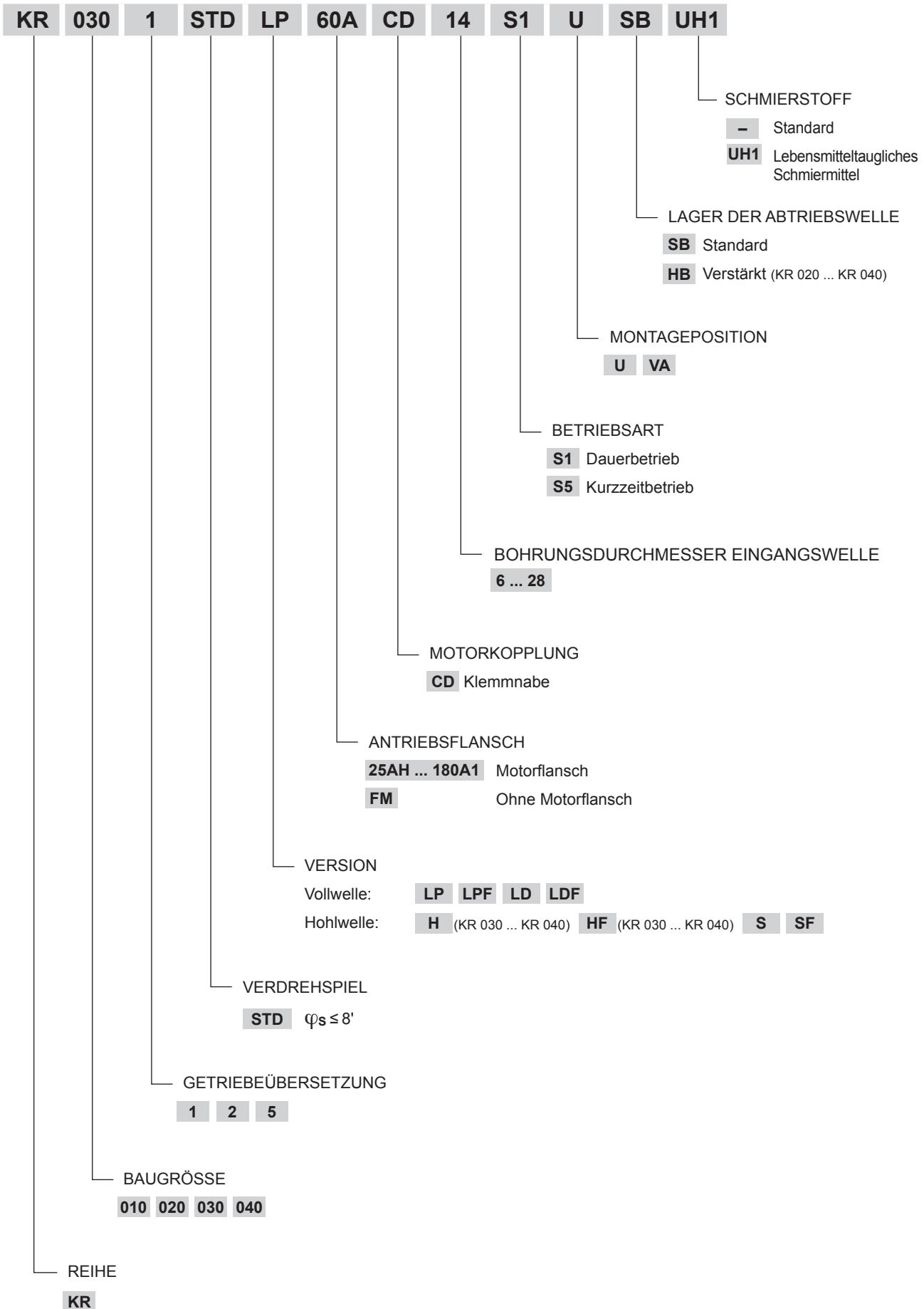

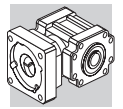

10.5 TECHNISCHE DATEN

KR 010								
	M_{n2}	M_{a2}	M_{p2}	C_t	n_1	$n_{1\max}$	φ_s	η
	[Nm]	[Nm]	[Nm]	$\left[\frac{Nm}{arcmin}\right]$	[min ⁻¹]	[min ⁻¹]	[arcmin]	%
i = 1	10	14	20	0.5	2000	4000	8'	97
i = 2	7	10	15	0.4	2500	5000		
i = 5	3	4	6	0.2	3000	5000		

KR 020								
	M_{n2}	M_{a2}	M_{p2}	C_t	n_1	$n_{1\max}$	φ_s	η
	[Nm]	[Nm]	[Nm]	$\left[\frac{Nm}{arcmin}\right]$	[min ⁻¹]	[min ⁻¹]	[arcmin]	%
i = 1	24	35	50	1.4	2000	4000	8'	97
i = 2	15	21	30	1.1	2500	5000		
i = 5	10	13	20	0.7	3000	5000		

KR 030								
	M_{n2}	M_{a2}	M_{p2}	C_t	n_1	$n_{1\max}$	φ_s	η
	[Nm]	[Nm]	[Nm]	$\left[\frac{Nm}{arcmin}\right]$	[min ⁻¹]	[min ⁻¹]	[arcmin]	%
i = 1	55	75	110	4	1500	3500	8'	97
i = 2	37	52	75	3	2000	4500		
i = 5	22	29	45	2	2800	4500		

KR 040								
	M_{n2}	M_{a2}	M_{p2}	C_t	n_1	$n_{1\max}$	φ_s	η
	[Nm]	[Nm]	[Nm]	$\left[\frac{Nm}{arcmin}\right]$	[min ⁻¹]	[min ⁻¹]	[arcmin]	%
i = 1	120	170	240	11	1500	3500	8'	97
i = 2	85	120	170	9	2000	4500		
i = 5	45	60	90	5	2500	4500		

Der angegebene Steifigkeit bezieht sich auf die LP-Version

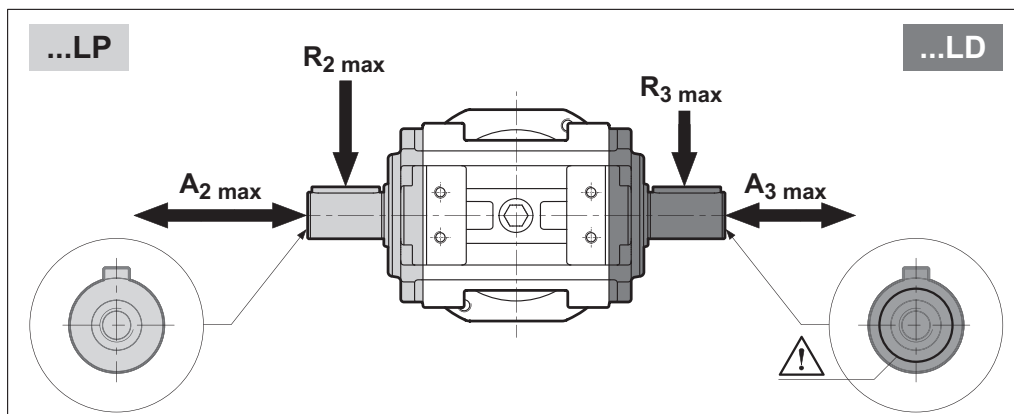

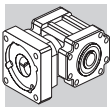

		...LP			...LD		
		$R_2\max$ [N]	$A_2\max$ [N]	$A_2'\max$ [N]	$R_3\max$ [N]	$A_3\max$ [N]	$A_3'\max$ [N]
KR 010	SB	1000	—	200	500	—	100
	HB	1500	—	300	750	—	150
KR 020	SB	3000	1500	600	3000	1500	600
	HB	2000	—	400	1000	—	200
KR 030	SB	4000	2000	800	4000	2000	800
	HB	3000	—	600	1500	—	300
KR 040	SB	5500	2750	1100	5500	2750	1100
	HB						





10.6 MASSETRÄGHEITSMOMENT

10.6.1 KR 010...KR 040 mit standard Kugellagern - SB

KR 010			
		J_G [kgcm ²]	
			
		$6 \leq D \leq 9.52$	$10 \leq D \leq 14$
i = 1	S, SF	0.52	0.52
	LP, LPF	0.38	0.38
	LD, LDF	0.39	0.39
i = 2	S, SF	0.27	0.29
	LP, LPF	0.24	0.25
	LD, LDF	0.24	0.25
i = 5	S, SF	0.20	0.21
	LP, LPF	0.19	0.21
	LD, LDF	0.19	0.21

KR 020			
		J_G [kgcm ²]	
			
		$8 \leq D \leq 12.7$	$14 \leq D \leq 19.05$
i = 1	S, SF	1.61	1.80
	LP, LPF	1.34	1.52
	LD, LDF	1.37	1.55
i = 2	S, SF	0.86	1.05
	LP, LPF	0.80	0.98
	LD, LDF	0.80	0.99
i = 5	S, SF	0.66	0.84
	LP, LPF	0.64	0.83
	LD, LDF	0.65	0.83

KR 030				
		J_G [kgcm ²]		
				
		$11 \leq D \leq 12.7$	$14 \leq D \leq 19$	$22 \leq D \leq 24$
i = 1	H, HF	4.37	4.45	4.64
	S, SF	5.00	5.08	5.27
	LP, LPF	4.70	4.78	4.97
	LD, LDF	4.63	4.71	4.90
i = 2	H, HF	2.04	2.12	2.31
	S, SF	2.20	2.28	2.47
	LP, LPF	2.12	2.20	2.39
	LD, LDF	2.11	2.19	2.37
i = 5	H, HF	1.47	1.55	1.74
	S, SF	1.50	1.57	1.76
	LP, LPF	1.48	1.56	1.75
	LD, LDF	1.48	1.56	1.75

KR 040				
		J_G [kgcm ²]		
				
		$14 \leq D \leq 19$	$22 \leq D \leq 24$	$D = 28$
i = 1	H, HF	17.19	17.37	17.77
	S, SF	20.46	20.65	21.05
	LP, LPF	18.21	18.40	18.80
	LD, LDF	18.90	19.08	19.48
i = 2	H, HF	4.47	4.65	5.06
	S, SF	5.29	5.47	5.87
	LP, LPF	4.73	4.91	5.31
	LD, LDF	4.90	5.08	5.48
i = 5	H, HF	5.23	5.42	5.82
	S, SF	5.36	5.55	5.95
	LP, LPF	5.27	5.46	5.86
	LD, LDF	5.30	5.49	5.89

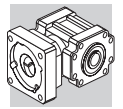

10.6.2 KR 020...KR 040 mit Kegelrollenlagern - HB

KR 020			
		J_G [kgcm ²]	
		$8 \leq D \leq 12.7$	$14 \leq D \leq 19.05$
i = 1	S, SF	1.87	2.06
	LP, LPF	1.60	1.78
	LD, LDF	1.62	1.81
i = 2	S, SF	0.93	1.12
	LP, LPF	0.86	1.05
	LD, LDF	0.87	1.05
i = 5	S, SF	0.67	0.85
	LP, LPF	0.66	0.84
	LD, LDF	0.66	0.84

KR 030				
		J_G [kgcm ²]		
		$11 \leq D \leq 12.7$	$14 \leq D \leq 19$	$22 \leq D \leq 24$
i = 1	H, HF	5.48	5.56	5.75
	S, SF	6.11	6.19	6.38
	LP, LPF	5.81	5.89	6.08
	LD, LDF	5.74	5.82	6.01
i = 2	H, HF	2.92	3.00	3.19
	S, SF	3.08	3.16	3.35
	LP, LPF	3.01	3.09	3.27
	LD, LDF	2.99	3.07	3.26
i = 5	H, HF	1.51	1.59	1.78
	S, SF	1.54	1.62	1.81
	LP, LPF	1.53	1.61	1.80
	LD, LDF	1.53	1.60	1.79

KR 040				
		J_G [kgcm ²]		
		$14 \leq D \leq 19$	$22 \leq D \leq 24$	$D = 28$
i = 1	H, HF	18.82	19.01	19.41
	S, SF	22.10	22.28	22.69
	LP, LPF	19.85	20.04	20.44
	LD, LDF	20.53	20.72	21.12
i = 2	H, HF	4.88	5.06	5.47
	S, SF	5.70	6.28	6.28
	LP, LPF	5.13	5.72	5.72
	LD, LDF	5.31	5.89	5.89
i = 5	H, HF	5.30	5.48	5.89
	S, SF	5.43	6.02	6.02
	LP, LPF	5.34	5.93	5.93
	LD, LDF	5.37	5.95	5.95

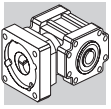

10.7 ABMESSUNGEN

KR 010

25AH ... 80A

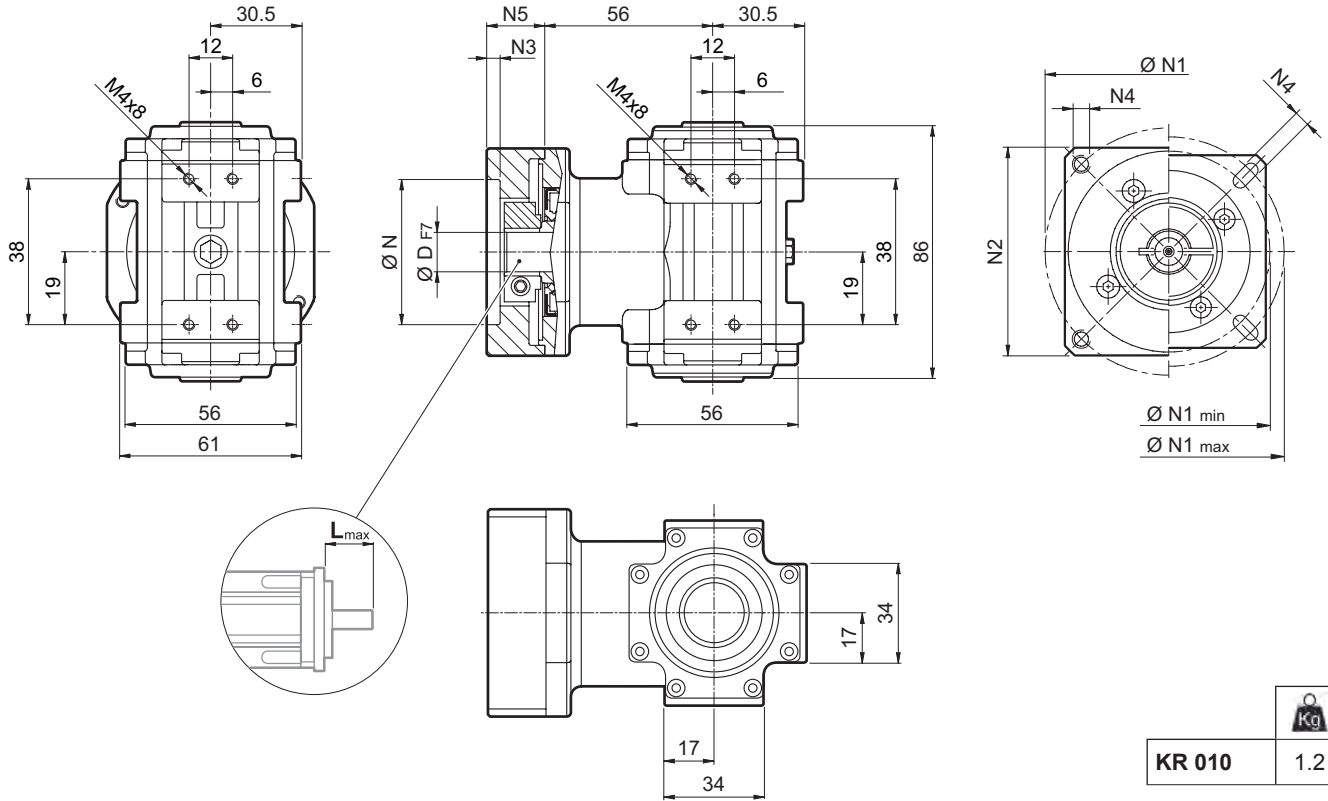

KR 010  1.2

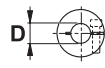
													N	N1		N2	N3	N4	N5	L _{max}
														min	max					
25AH	6	6.35	7	8	9	9.52	-	-	-	-	-	25	39	56						
26AH	6	6.35	7	8	9	9.52	-	-	-	-	-	26	39	56						
28AH	6	6.35	7	8	9	9.52	-	-	-	-	-	28	39	56						
30AH	6	6.35	7	8	9	9.52	-	-	-	-	-	30	39	56						
32AH	6	6.35	7	8	9	9.52	-	-	-	-	-	32	39	56	65	3.5	4.5	25	25	
34AH	6	6.35	7	8	9	9.52	-	-	-	-	-	34	40	56						
36AH	6	6.35	7	8	9	9.52	-	-	-	-	-	36	42	56						
39AH	6	6.35	7	8	9	9.52	-	-	-	-	-	39	45	56						
40AH	6	6.35	7	8	9	9.52	-	-	-	-	-	40	46	56						
38B	6	6.35	7	8	9	9.52	10	11	12	12.7	-	38.1	66.6	60	3	M4x10	18	25		
40B	6	6.35	7	8	9	9.52	10	11	12	12.7	-	40	63	60	3	M4x10	18	25		
50A	6	6.35	7	8	9	9.52	10	11	12	12.7	-	50	60	60	3	M4x10	18	25		
50B	6	6.35	7	8	9	9.52	10	11	12	12.7	14	50	65	60	3	M5x12	23	30		
50BH	6	6.35	7	8	9	9.52	10	11	12	12.7	14	50	65	65	3	5.5	25	32		
50C	6	6.35	7	8	9	9.52	10	11	12	12.7	14	50	70	60	3	M4x10	23	30		
55MH	6	6.35	7	8	9	9.52	10	11	12	12.7	-	55	80	65	2	5.5	16	23		
60A	6	6.35	7	8	9	9.52	10	11	12	12.7	-	60	75	65	3	M5x12	18	25		
60A1	6	6.35	7	8	9	9.52	10	11	12	12.7	14	60	75	65	3	M5x12	23	30		
60B	6	6.35	7	8	9	9.52	10	11	12	12.7	14	60	85	75	3	M5x12	23	30		
60C	6	6.35	7	8	9	9.52	10	11	12	12.7	14	60	90	75	3	M5x12	23	30		
70A	6	6.35	7	8	9	9.52	10	11	12	12.7	14	70	85	75	3	M6x15	23	30		
70B	6	6.35	7	8	9	9.52	10	11	12	12.7	14	70	90	75	3	M5x12	23	30		
73A	6	6.35	7	8	9	9.52	10	11	12	12.7	14	73	98.4	85	3	M5x12	25	32		
80A	6	6.35	7	8	9	9.52	10	11	12	12.7	14	80	100	85	3	M6x15	23	30		

Für weitere Motoradapter und Antriebswellenbohrungen bitte nachfragen.

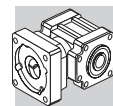

KR 010

KR 010... S

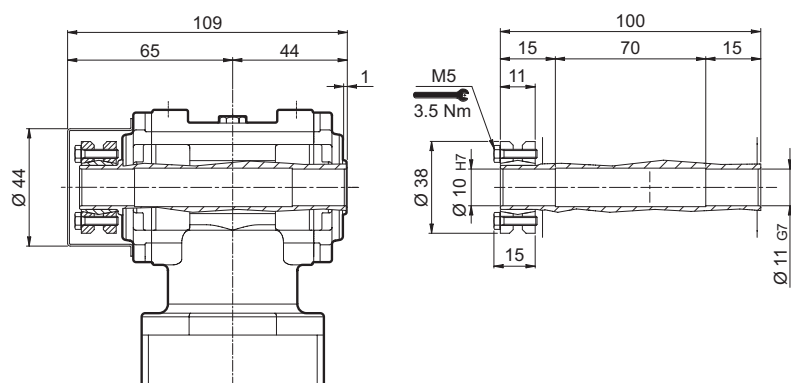

KR 010... SF

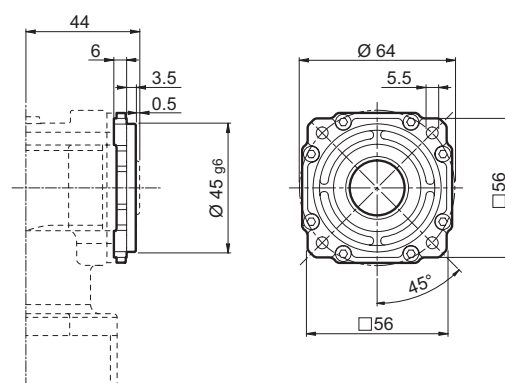

KR 010... LP

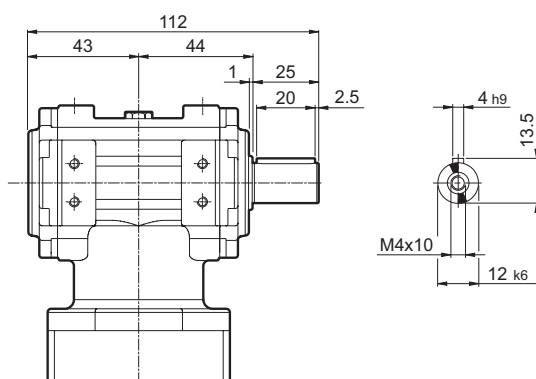

KR 010... LPF

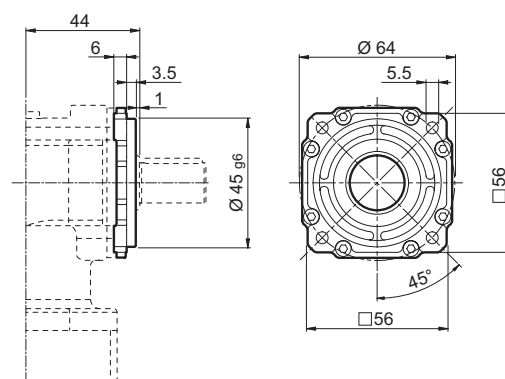

KR 010... LD

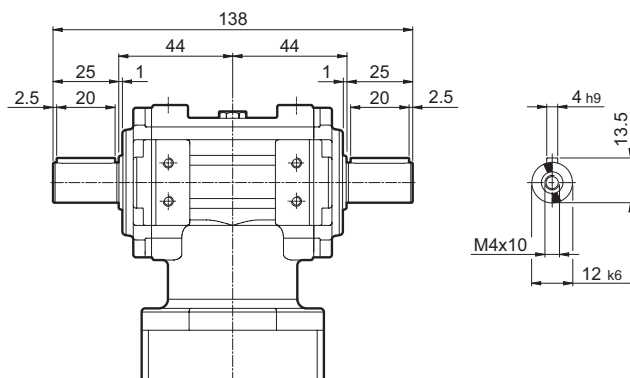

KR 010... LDF

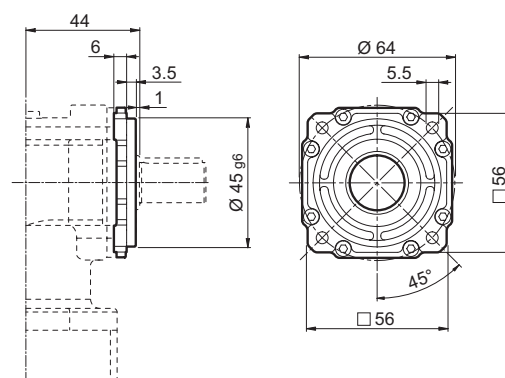

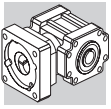

KR 020

40B1 ... 110B1

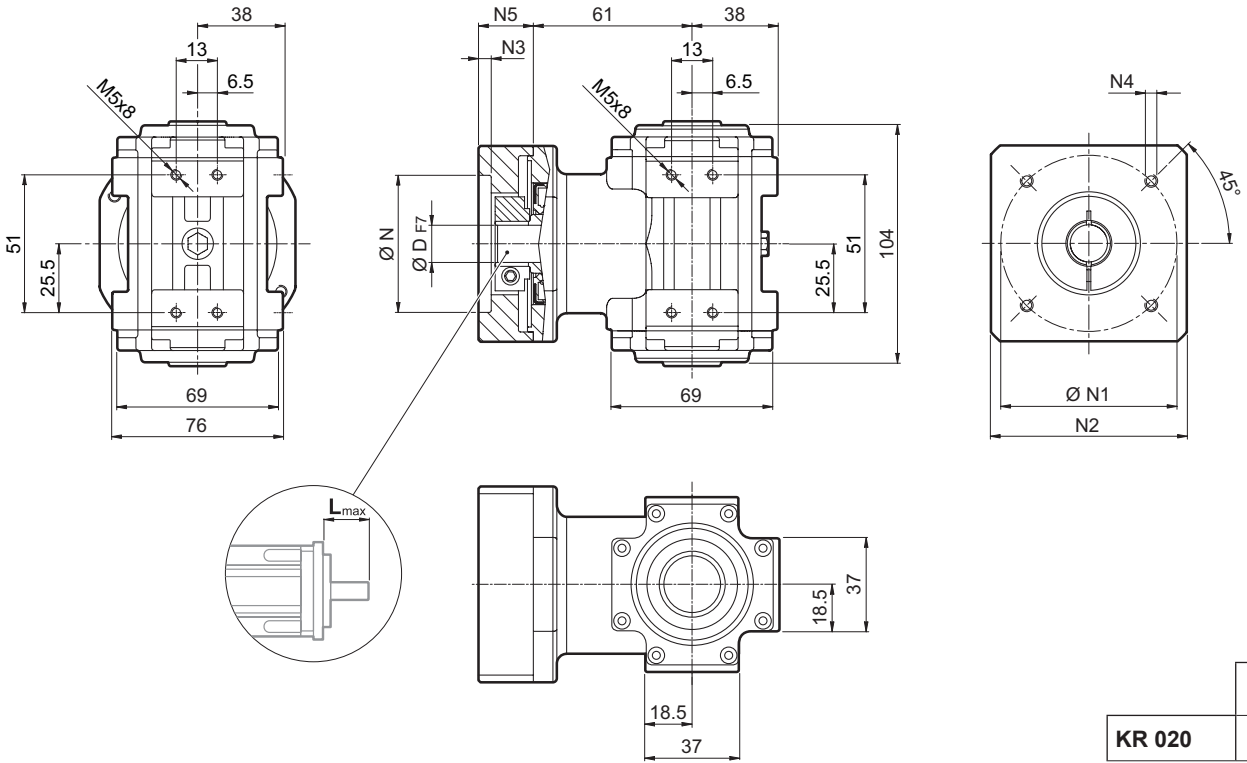

	KR 020	2.6

												N	N1	N2	N3	N4	N5	L _{max}	
	8	9	9.52	11	12	12.7	14	-	-	-	-								
40B1	8	9	9.52	11	12	12.7	14	-	-	-	-	40	63	80	4	M4x10	34	40	
45A	8	9	9.52	11	12	12.7	-	-	-	-	-	45	63	80	4	M4x10	34	40	
50B1	8	9	9.52	11	12	12.7	14	-	-	-	-	50	65	80	4	M5x16	34	40	
50BH1	8	9	9.52	11	12	12.7	14	-	-	-	-	50	65	80	4	5.5	34	40	
50C1	8	9	9.52	11	12	12.7	14	-	-	-	-	50	70	80	4	M4x10	34	40	
50D	8	9	9.52	11	12	12.7	14	-	-	-	-	50	95	80	4	M6x10	34	40	
55A	8	9	9.52	11	12	12.7	14	15.875	16	17	19	19.05	55.5	125.7	105	4	M6x16	34	40
60A2	8	9	9.52	11	12	12.7	14	-	-	-	-	60	75	80	4	M5x16	34	40	
60AH2	8	9	9.52	11	12	12.7	14	-	-	-	-	60	75	90	4	5.5	34	40	
60B1	8	9	9.52	11	12	12.7	14	15.875	16	-	-	60	85	80	4	M5x16	34	40	
60C1	8	9	9.52	11	12	12.7	14	15.875	16	-	-	60	90	80	4	M5x16	34	40	
70A1	8	9	9.52	11	12	12.7	14	15.875	16	17	19	19.05	70	85	80	4	M6x20	34	40
70AH1	8	9	9.52	11	12	12.7	14	15.875	16	17	19	19.05	70	85	90	4	6.5	34	40
70B1	8	9	9.52	11	12	12.7	14	15.875	16	17	19	19.05	70	90	80	4	M5x16	34	40
73A1	8	9	9.52	11	12	12.7	14	-	-	-	-	73	98.4	85	4	M5x16	34	40	
80A1	8	9	9.52	11	12	12.7	14	15.875	16	17	19	19.05	80	100	90	4	M6x16	34	40
95A	8	9	9.52	11	12	12.7	14	15.875	16	17	19	19.05	95	115	100	4	M8x20	34	40
95B	8	9	9.52	11	12	12.7	14	15.875	16	17	19	19.05	95	130	115	4	M8x20	34	40
110A	8	9	9.52	11	12	12.7	14	15.875	16	17	19	19.05	110	130	115	4	M8x20	34	40
110B	8	9	9.52	11	12	12.7	14	15.875	16	17	19	19.05	110	145	120	6.5	M8x20	44	50
110B1	8	9	9.52	11	12	12.7	14	15.875	16	17	19	19.05	110	145	120	6.5	M8x20	54	60

Für weitere Motoradapter und Antriebswellenbohrungen bitte nachfragen.

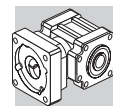

KR 020

KR 020... S

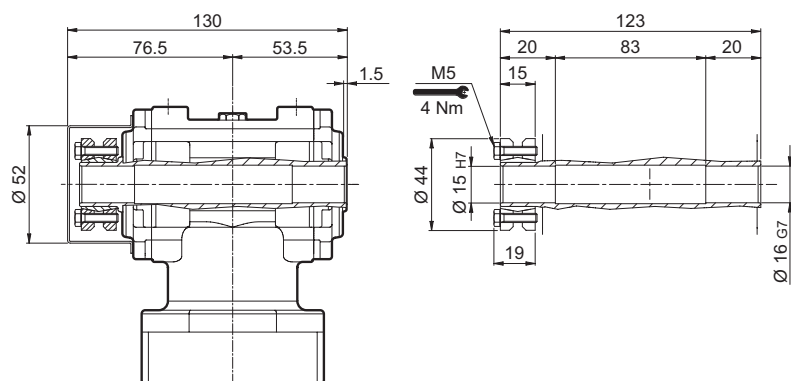

KR 020... SF

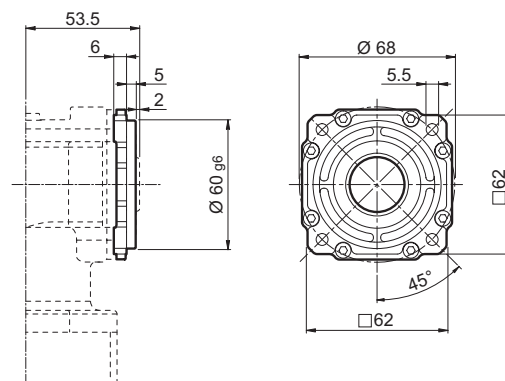

KR 020... LP

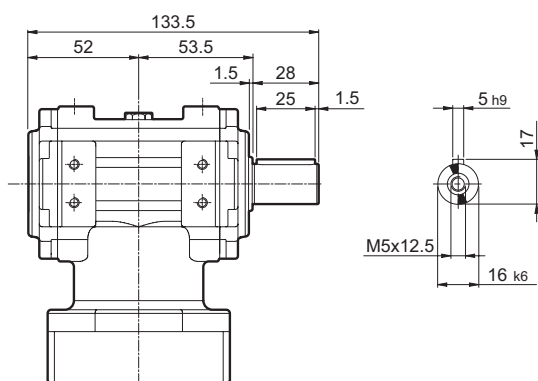

KR 020... LPF

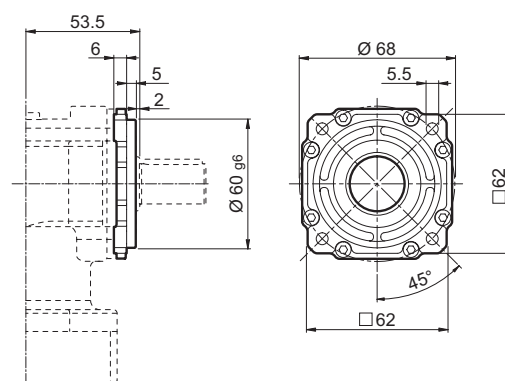

KR 020... LD

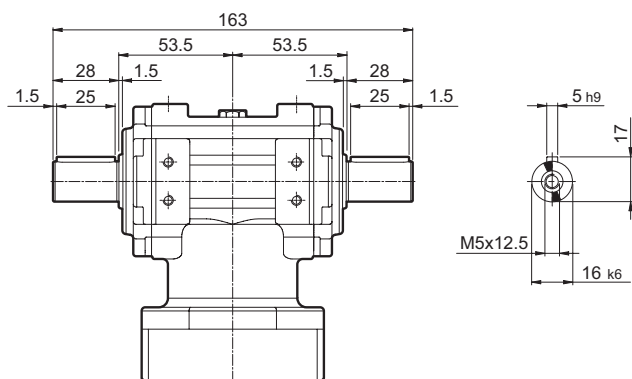

KR 020... LDF

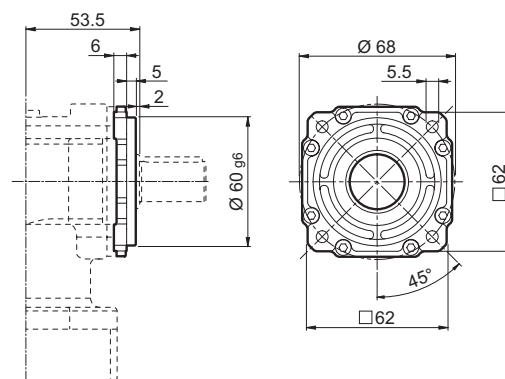

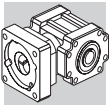

KR 030

50D ... 130A1

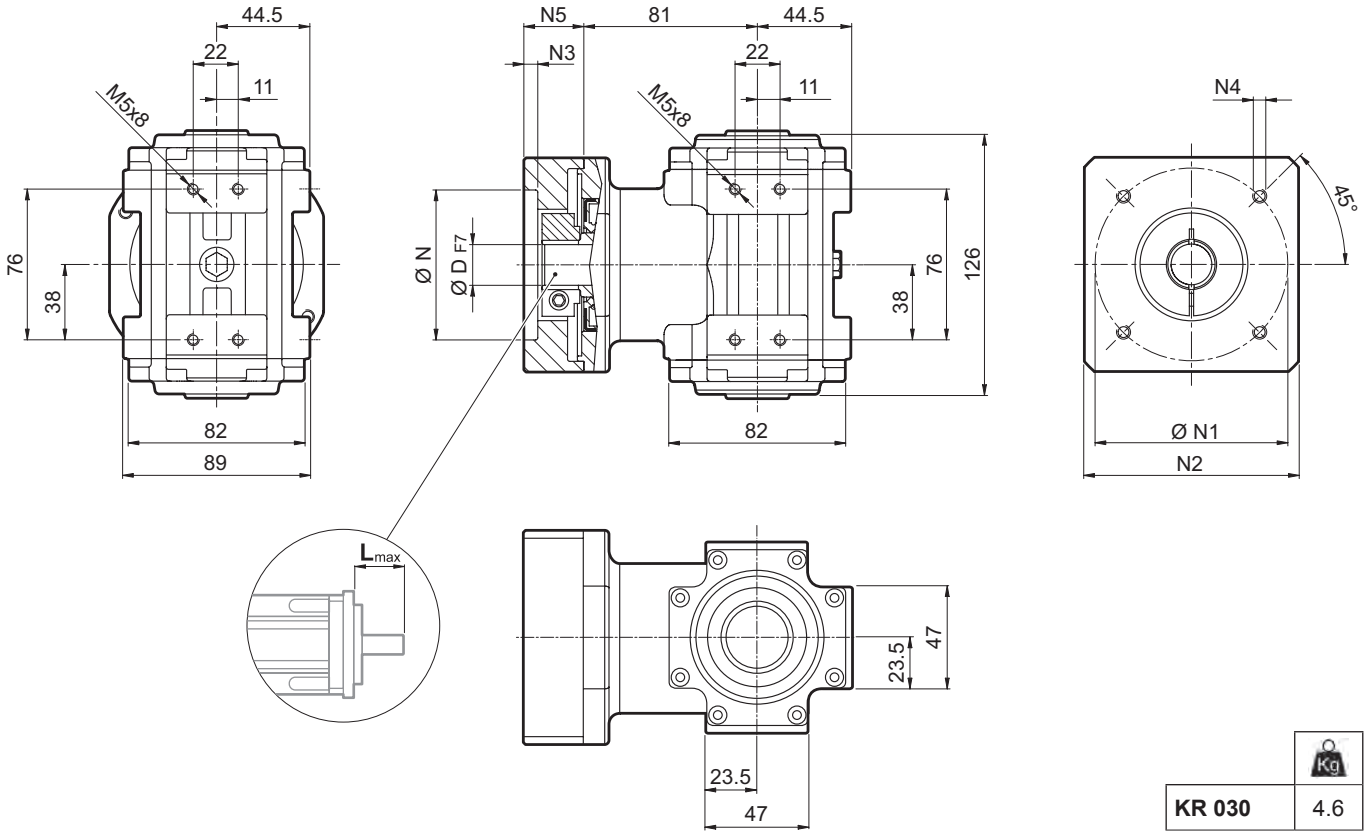

	Kg
KR 030	4.6

											N	N1	N2	N3	N4	N5	L _{max}
	11	12	12.7	14	15	15.875	16	19	—	—							
50D	11	12	12.7	14	15	15.875	16	19	—	—	50	95	100	5	M6x14	28	40
55A	11	12	12.7	14	15	15.875	16	19	—	—	55.5	125.7	105	5	M6x16	28	40
60A2	11	12	12.7	14	15	15.875	16	19	—	—	60	75	100	5	M5x14	28	40
60AH2	11	12	12.7	14	15	15.875	16	19	—	—	60	75	100	5	6.5	33	40
60B1	11	12	12.7	14	15	15.875	16	19	—	—	60	85	100	6.5	M5x14	28	40
70A1	11	12	12.7	14	15	15.875	16	19	—	—	70	85	100	5	M6x14	28	40
70AH1	11	12	12.7	14	15	15.875	16	19	—	—	70	85	100	5	6	33	40
70B1	11	12	12.7	14	15	15.875	16	19	—	—	70	90	100	5	M5x12	28	40
80A1	11	12	12.7	14	15	15.875	16	19	—	—	80	100	100	5	M6x16	28	40
80AH1	11	12	12.7	14	15	15.875	16	19	—	—	80	100	100	5	6.5	28	40
95A	11	12	12.7	14	15	15.875	16	19	—	—	95	115	100	5	M8x18	28	40
95A1	11	12	12.7	14	15	15.875	16	19	22	24	95	115	100	5	M8x18	38	50
95B	11	12	12.7	14	15	15.875	16	19	—	—	95	130	115	5	M8x18	28	40
110A	11	12	12.7	14	15	15.875	16	19	—	—	110	130	115	5	M8x18	28	40
110A1	11	12	12.7	14	15	15.875	16	19	22	24	110	130	115	6.5	M8x20	38	50
110B	11	12	12.7	14	15	15.875	16	19	22	24	110	145	120	6.5	M8x20	38	50
110B1	11	12	12.7	14	15	15.875	16	19	22	24	110	145	120	6.5	M8x20	48	60
130A	11	12	12.7	14	15	15.875	16	19	22	24	130	165	140	6.5	M10x20	38	50
130A1	11	12	12.7	14	15	15.875	16	19	22	24	130	165	140	6.5	M10x25	48	60

Für weitere Motoradapter und Antriebswellenbohrungen bitte nachfragen.

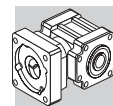

KR 030

KR 030... H

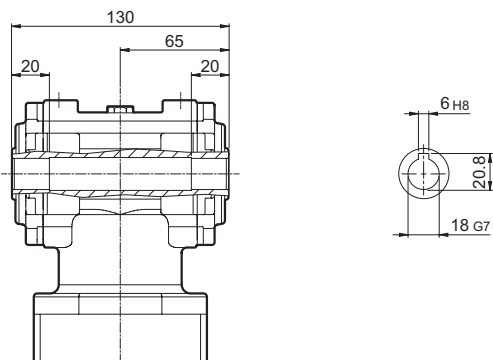

KR 030... HF

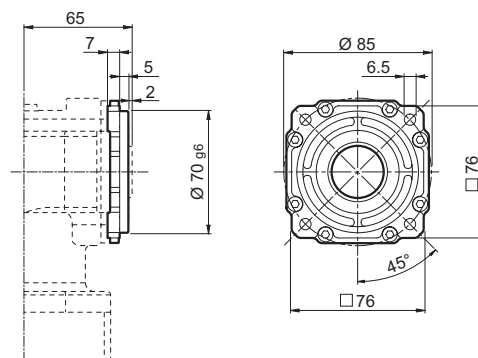

KR 030... S

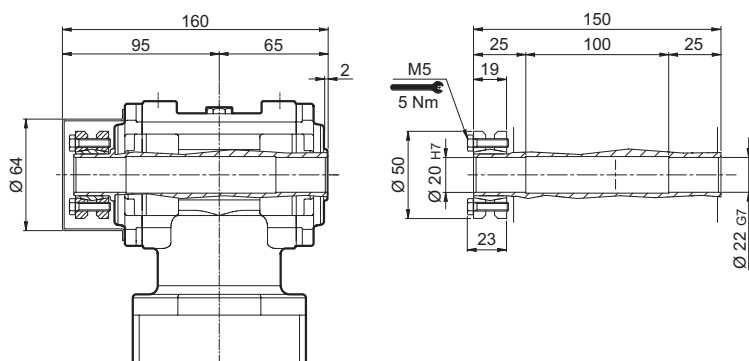

KR 030... SF

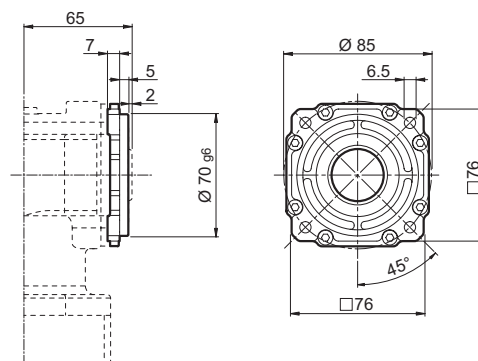

KR 030... LP

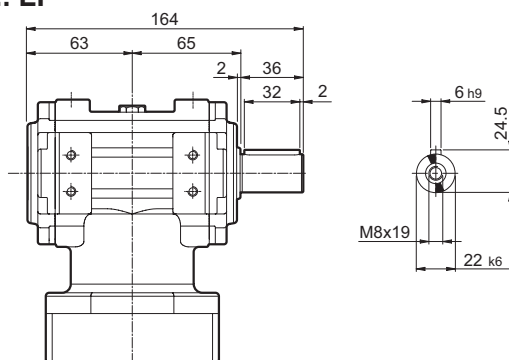

KR 030... LPF

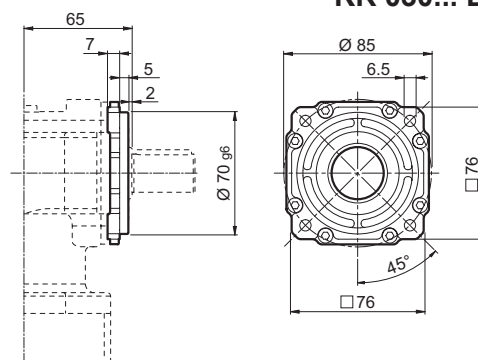

KR 030... LD

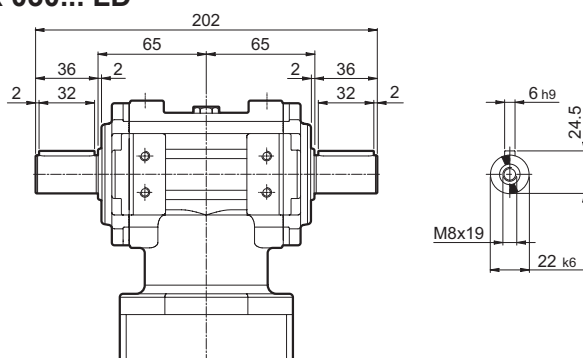

KR 030... LDF

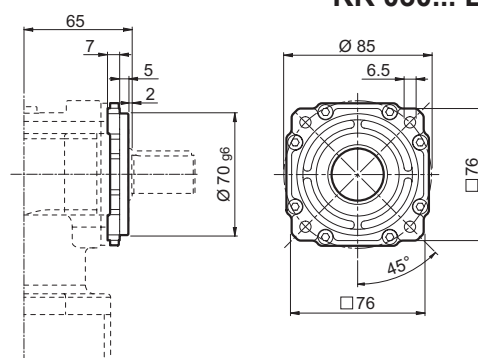

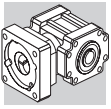

KR 040

55A1 ... 180A1

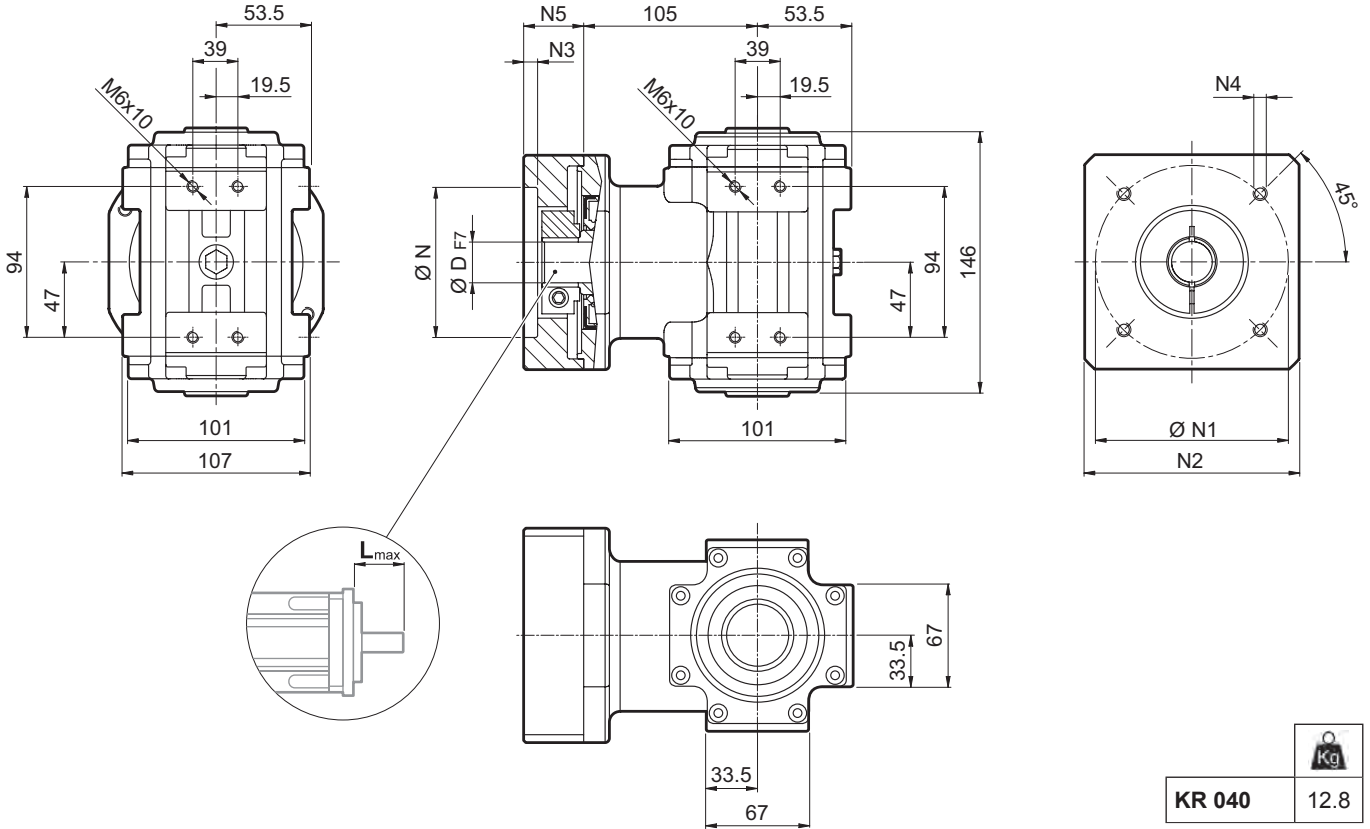

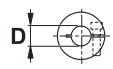
								N	N1	N2	N3	N4	N5	L _{max}
	14	15.875	16	19	22	24	28							
55A1	14	15.875	16	19	-	-	-	55.5	125.7	130	4	M6x15	39.5	50
80A2	14	15.875	16	19	-	-	-	80	100	130	4	M6x15	39.5	50
95A1	14	15.875	16	19	22	24	-	95	115	130	4	M8x20	39.5	50
110A1	14	15.875	16	19	22	24	-	110	130	130	4	M8x20	39.5	50
110B1	14	15.875	16	19	22	24	-	110	145	130	6.5	M8x20	49.5	60
114A	14	15.875	16	19	22	24	28	114.3	200	170	5.5	M12x25	69.5	80
130A	14	15.875	16	19	22	24	-	130	165	140	4	M10x20	39.5	50
130A1	14	15.875	16	19	22	24	28	130	165	140	4	M10x20	49.5	60
180A	14	15.875	16	19	22	24	28	180	215	190	5.5	M14x25	49.5	60
180A1	14	15.875	16	19	22	24	28	180	215	190	5.5	M14x25	69.5	80

Für weitere Motoradapter und Antriebswellenbohrungen bitte nachfragen.

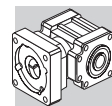

KR 040

KR 040... H

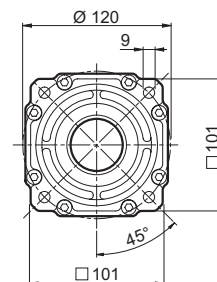
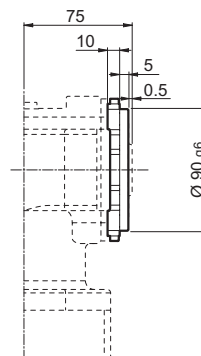
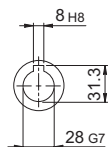
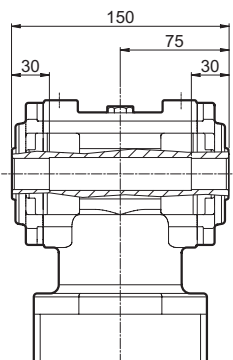

KR 040... HF

KR 040... S

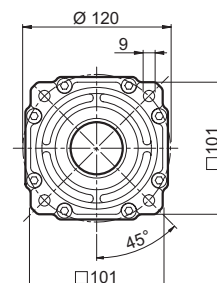
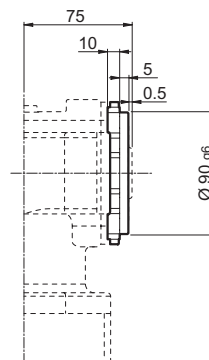
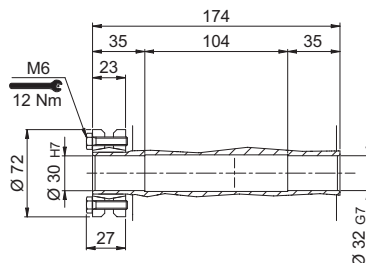
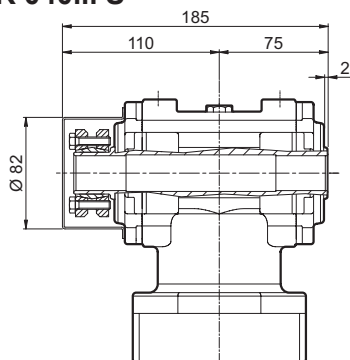

KR 040... SF

KR 040... LP

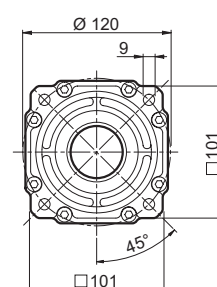
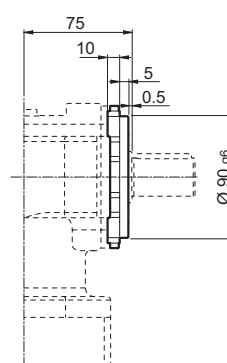
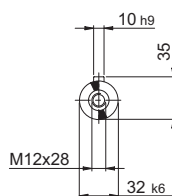
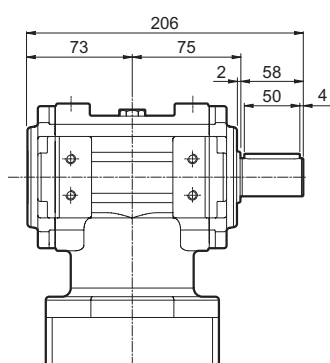

KR 040... LPF

KR 040... LD

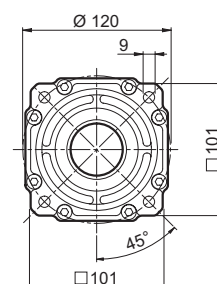
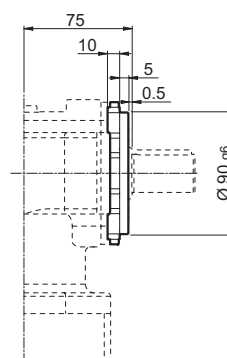
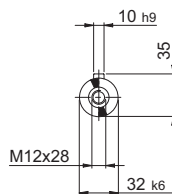
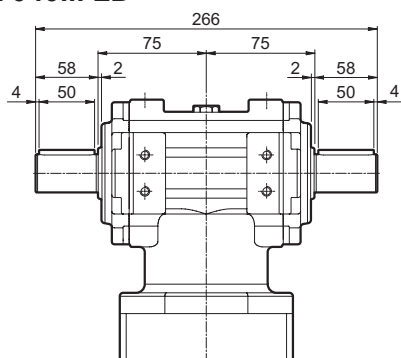

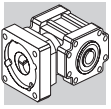

KR 040... LDF

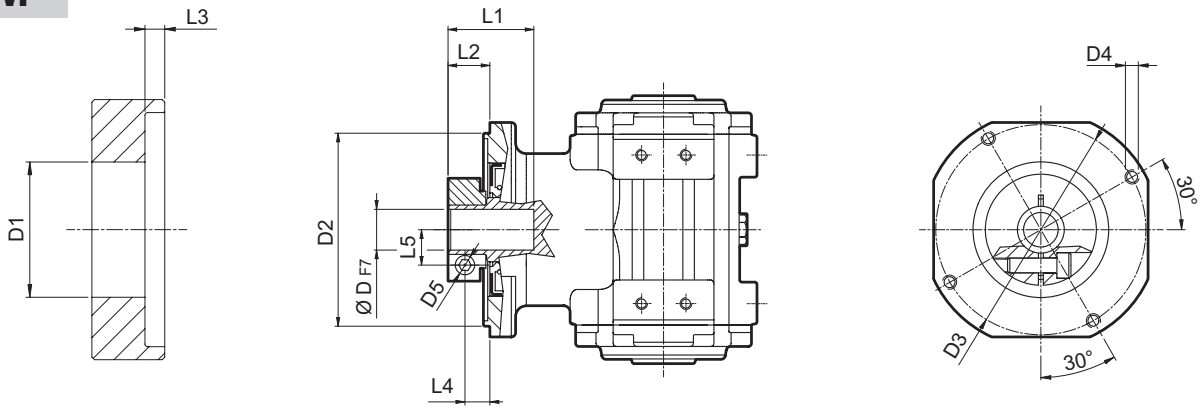

10.7.1 GETRIEBE OHNE MOTORADAPTER

FM

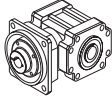

		D1	D2	D3	D4	D5	L1	L2	L3	L4	L5	
KR 010	6 6.35 7	32.5	50	42.5	M4x8	M4	28	13.5	3	8.5	8	1.0
	8 9 9.52 10	32.5	50	42.5	M4x8	M4	28	13.5	3	8.5	9	
	11 12 12.7	35.5	50	42.5	M4x8	M4	23	13.5	3	8.5	11	
	14	35.5	50	42.5	M4x8	M4	25	15.5	3	8.9	11.5	
KR 020	8 9 9.52	38	68	76.5	M6x10	M6	36.3	26.3	9.5	18.8	10.5	2.0
	11 12 12.7	43	68	76.5	M6x10	M6	36.3	26.3	9.5	18.8	12.5	
	14 15.875 16 17	48	68	76.5	M6x10	M6	36.3	26.3	9.5	18.8	14.5	
	19 19.05	51	68	76.5	M6x10	M6	36.3	26.3	9.5	18.8	16.5	
KR 030	11 12 12.7	43	90	98	M6x15	M6	35	19.5	7.6	12.1	12.5	3.5
	14 15 15.875 16	48	90	98	M6x15	M6	35	19.5	7.6	12.1	14.5	
	19	51	90	98	M6x15	M6	35	19.5	7.6	12.1	16.5	
	22 24	56.5	90	98	M6x15	M6	37	21.5	7.6	12.1	19	
KR 040	14 15.875 16	48	113	125.5	M8x15	M6	46	27.5	6	20	14.5	10.0
	19	51	113	125.5	M8x15	M6	46	27.5	6	20	16.5	
	22 24	56.5	113	125.5	M8x15	M6	47.5	29	6	20	19	
	28	67	113	125.5	M8x15	M8	47.5	29	6	20	22.5	

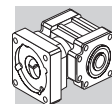



10.7.2 MASCHINENWELLE

Für die Welle der angetriebenen Maschine ist eine hochwertige Stahllegierung zu bevorzugen. Die Tabelle unten zeigt die empfohlenen Abmessungen, die vom Kunden bei der Konstruktion der Gegenwelle zu berücksichtigen sind. Weiterhin wird eine axiale Aufnahmevorrichtung für die Welle empfohlen (nicht gezeigt).

Anzahl und Größe der entsprechenden Gewindebohrungen am Wellenende sind von den Anwendungsanforderungen abhängig.

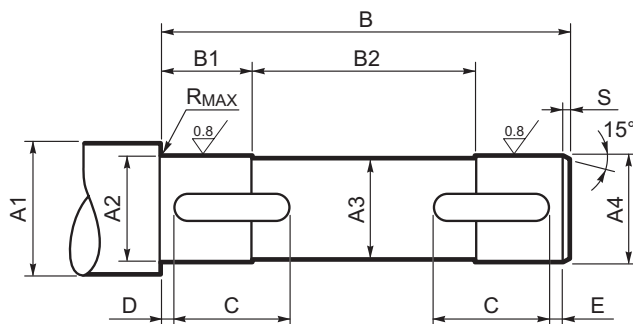
H

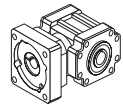

	A1	A2	A3	A4	B	B1	B2	C	D	E	R _{MAX}	 UNI 6604	S
KR 030	≥ 26	18 h7	17	18 h7	129	18	90	32	2	2	0.5	6x6x25 A	1
KR 040	≥ 36	28 h7	27	28 h7	149	28	90	50	2	2	0.5	8x7x35 A	

Hinweis: Bei Verbindung der Welle mit Passfeder wie oben beschrieben erhöht sich das Flankenspiel in der Anwendung ($\varphi_s \leq 8^\circ$).

S

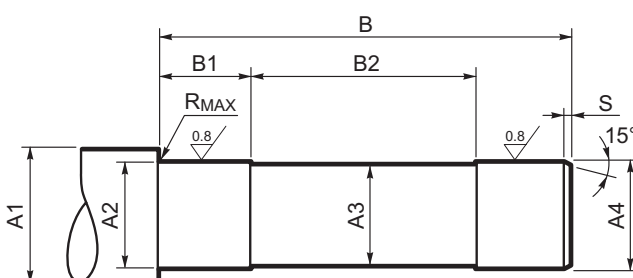

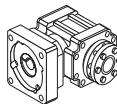
	A1	A2	A3	A4	B	B1	B2	R _{MAX}	S
KR 010	≥ 15	11 h7	9.5	10 h6	99	13	70	0.5	1
KR 020	≥ 20	16 h7	14.5	15 h6	122	18	83	0.2	
KR 030	≥ 30	22 h7	19.5	20 h6	149	23	100	0.5	
KR 040	≥ 40	32 h7	29.5	30 h6	173	33	104	0.5	



REVISIONSSINDEX

	TI_CAT_TIR_STD_DEU_R03_0
	Beschreibung
...	Überarbeitung einiger technischer Daten.

2016 06 20

Diese Publikation ersetzt alle vorhergehenden Ausgaben und Überarbeitungen. Wir behalten uns das Recht vor, Veränderungen ohne Ankündigung umzusetzen.
Dieser Katalog darf ohne vorherige Genehmigung weder vollständig noch auszugsweise reproduziert werden.



Seit 1956 plant und realisiert Bonfiglioli innovative und zuverlässige Lösungen für die Leistungsüberwachung und -übertragung in industrieller Umgebung und für selbstfahrende Maschinen sowie Anlagen im Rahmen der erneuerbaren Energien.

HEADQUARTERS

Bonfiglioli Riduttori S.p.A.
Via Giovanni XXIII, 7/A
40012 Lippo di Calderara di Reno
Bologna (Italy)

tel: +39 051 647 3111
fax: +39 051 647 3126
bonfiglioli@bonfiglioli.com
www.bonfiglioli.com

TI_CAT_TIR_STD_DEU_R03_0

